

We Create Featured Products

Product Solution Guide

Wide-Temperature Fanless Embedded System

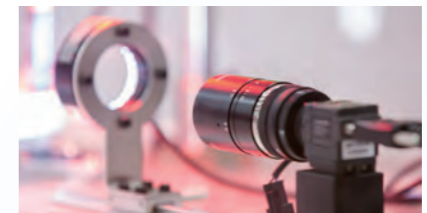
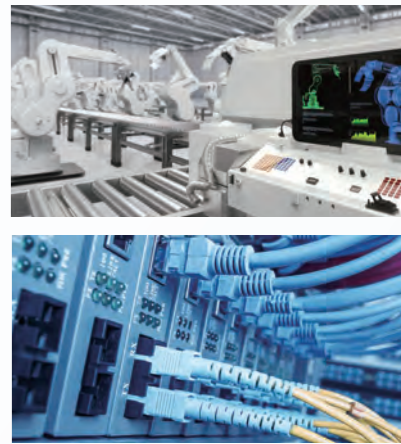

www.neosys-tech.com

Neosys Technology, Inc.
15F., No.868-3, Zhongzheng Rd.,
Zhonghe Dist., New Taipei City, 23586, Taiwan
Tel: +886-2-22236182 Fax: +886-2-22236183
E-mail: sales@neosys-tech.com

Neosys Technology America Inc.
3384 Commercial Avenue, Northbrook,
IL 60062, USA
Tel: +1-847-656-3298
E-mail: sales@neosys-tech.com

Neosys Technology (China), Ltd.
Room 612, Building 32, Guiping Road 680,
Shanghai, 200233, China
Tel: +86-2161155366 Fax: +86-21-61155367
E-mail: sales.cn@neosys-tech.com

Vol. 2018A2

www.neosys-tech.com

Vol. 2018A2



About Neousys



Established in 2010, Neousys Technology designs and manufactures rugged embedded modules and systems with core expertise ranging from embedded computing to data acquisition and processing. Our dedication to innovate and integrate practical application-oriented functions set us apart from the rest and our products are ideal solutions for automation, machine vision, transportation, GPU computing, surveillance and video analytics.

Neousys Technology application-oriented systems thrive in the following field:

- Wide-temperature fanless computing
- Rugged embedded fanless computing
- Machine vision platforms
- In-vehicle fanless PC
- Ultra compact fanless controller
- Surveillance/ video analytics computing
- GPU computing



Rugged Embedded

Nuvo-7000E/ P/DE P. 20
Intel® 8th-Gen Coffee Lake Core™ i7/ i5/ i3 Fanless Controller with 6x GbE Ports, Patented Cassette and MeziO™ Interface

Nuvo-7000LP P. 23
Intel® 8th-Gen Coffee Lake Core™ i7/ i5/ i3 Fanless Controller with 6x GbE Ports, MeziO™ Interface and Low-profile Chassis

Nuvo-5026E P. 25
Intel® 6th-Gen Core™ i7/ i5/ i3 Fanless Controller with Dual PCIe Slot Expansion Cassette, 6x GbE and MeziO™ Interface

Nuvo-5501 P. 27
Intel® 6th-Gen Core™ i7/ i5/ i3 Compact Fanless Embedded Controller with 3x GbE

Nuvo-5000E/ P P. 29
Intel® 6th-Gen Core™ i7/ i5/ i3 Fanless Controller with 6x GbE, Expansion Cassette and MeziO™ Interface

Nuvo-5000LP P. 31
Intel® 6th-Gen Core™ i7/i5/i3 Fanless Controller with 6x GbE, MeziO™ Interface and Low-profile Chassis

Nuvo-3000E/ P P. 33
Intel® 3rd-Gen Core™ i7/ i5/ i3 Fanless Controller with 5x GbE, 4x USB3.0 and Expansion Cassette

Nuvo-3005LP P. 35
Intel® 3rd-Gen Core™ i7/ i5 Low Profile Fanless Embedded System with Swappable HDD Tray

Nuvo-3000TB P. 37
Intel® 3rd-Gen Core™ i7/ i5/ i3 Fanless Embedded Controller with 3.5" Storage Capacity

Nuvo-3120 P. 39
Compact Intel® 3rd-Gen Core™ i7/ i5 Fanless Controller with Configurable CPU Power Mode

Nuvo-2500E/ P P. 41
Intel® Celeron® Bay Trail Fanless Computer with Expansion Cassette

Nuvo-6000 P. 43
Intel® 6th-Gen Core™ i7/ i5/ i3 Fanless Box-PC with Up to 5 PCIe/ PCI Expansion Slots

Nuvo-4000 P. 45
Intel® 3rd-Gen Core™ i7/ i5 Fanless Box-PC with 4x PCIe/ PCI Expansion Slots

Nuvo-2400 P. 47
Intel® Celeron® Bay Trail fanless Shoebox IPC with Dual Display Output, dual GbE and triple PCI/PCIe slots

PB-2500J P. 49
Industrial-Grade Intelligent Ultracapacitor-based Power Backup Module

POC-300 P. 51
Intel® Apollo Lake Pentium® N4200 and Atom™ E3950 Ultra-Compact DIN-rail Controller with GbE, PoE and USB3.0

POC-200 P. 53
Ultra-Compact Atom™ Bay Trail-I Fanless Embedded Controller with PoE and USB3.0

POC-120 P. 55
Ultra-compact Atom™ Bay Trail-I Fanless General-Purpose Embedded Controller

ETHY-100-2008(S) P. 57
Ethernet I/O Expansion Module with 8 Digital Inputs and 8 Digital outputs

IGT-20 P. 59
Industrial Grade ARM-based Smart Wireless IoT Gateway Device with ARM Cortex A8, Dual T-Flash (microSD), and Pre-installed Debian



Machine Vision

Nuvis-5306RT P. 61
Intel® 6th-Gen Core™ i7/ i5 Vision Controller with Vision-Specific I/O, Real-time Control and GPU-Computing

Nuvis-3304at P. 63
Intel® 3rd-Gen Core™ i7/ i5 Fanless Vision System with 4x GigE PoE and Deterministic Trigger I/O

iVIS-200 P. 65
Intel® Atom™ E3845 Processor Board for x86-based Smart Camera Framework

PCIe-PoE550X..... P. 67
2-port 10GbE Network Adapter with IEEE 802.3at PoE+ Capability

PCIe-PoE334LP P. 68
Low-profile 4-port Server-grade Gigabit PoE+ Card with 1 kV Surge Protection

PCIe-PoE354at/352at P. 69
4-Port / 2-Port Server-grade Gigabit 802.3at PoE+ Frame Grabber Card

PCIe-USB380/ 340 P. 70
8-Port/ 4-Port USB3.0 Host Adapter Card with 4x Independent USB3.0 Controllers



In-Vehicle Computing

POC-351VTC P. 71
Intel® Apollo Lake Atom™ E3950 Ultra-compact In-vehicle Controller with GbE, PoE+ and Isolated CAN bus

Nuvo-5100VTC P. 73
Intel® 6th-Gen Core™ i7/i5/i3 In-Vehicle Controller with 4x or 8x PoE+ Ports, DIO, CAN bus and RAID

Nuvo-3100VTC P. 75
Intel® 3rd-Gen Core™ i7/ i5 Fanless In-vehicle Controller with 4x 802.3at PoE+ Ports and Dual 2.5" Hard Drives with RAID Support

Nuvo-2510VTC P. 77
Intel® Atom™ Bay Trail In-vehicle Fanless Computer with 2x IEEE 802.3at PoE+ Ports

Nuvo-7100VTC P. 79
Intel® 8th-Gen Core™ i7/i5/i3 In-Vehicle Controller with 4x or 8x PoE+ Ports, DIO, CAN bus and RAID



Surveillance/ Video Analytics

Nuvo-5608VR P. 81
Intel® 6th-Gen Core™ i7/i5 Fanless Surveillance System with 8x PoE+, DIO, CAN bus and 2x 3.5" HDD Accommodation Supporting RAID 0/1

Nuvo-3616VR P. 83
Intel® 3rd-Gen Core™ i7/ i5 Fanless Surveillance System Featuring 16x 802.3at PoE+ Ports and Four 2.5" Hard Drives with RAID Support

EDX-104 P. 85
5-port IEEE 802.3at PoE+ Gigabit Unmanaged Industrial Ethernet Switch with PoE+ PD and DC Dual Power Input



GPU Computing

Nuvo-7160GC P. 87
Ruggedized GPU-Computing Platform Supporting 120W NVIDIA® GPU and Intel® 8th-Gen Core™ Processor

Nuvo-6108GC-IGN P. 89
Industrial-grade in-vehicle GPU-computing Platform with 250W NVIDIA® GPU and Intel® Xeon® E3 v5 and 6th-Gen Core™ Processor

Nuvo-6108GC P. 91
Industrial-grade GPU Computing Platform Supporting 250W NVIDIA® GPU and Intel® Xeon® E3 v5 or 6th-Gen Core™ Processor

Nuvo-5095GC P. 93
Compact and Wide-Temperature GPU-Computing Platform Supporting 75W NVIDIA® GPU and Intel® 6th-Gen Core™ Proces

Add on

Neousys MeziO™ Modules P. 95

Accessories P. 100

PCIe/PCI Expansion Cassette

(R.O.C Patent No. M456527)

Neosys' patented Cassette technology innovates a brilliant way for accommodating add-on cards. The modularized design is easy to install or replace and it offers passive cooling to the add-on card for reliable operation. Customers can install any PCI or PCIe card in the Cassette, or choose Neosys' selection of standard cassette modules with preinstalled heat-spreader for PoE+, USB3.0 or independent graphics card.



Concept of Cassette

As the dedicated heat-spreader makes contact with components and the heat is conducted to the surface of the Cassette enclosure, it is able to sustain a stable internal thermal condition.

- Two enclosures, one dedicated for the system and the other dedicated for add-on cards, separate compartments to minimize electrical and thermal interference
- Reliable mechanical/ electrical connection between system and Cassette



*Cassette is applicable to Nuvo-5000E/P, Nuvo-5026E, Nuvo-5095GC, Nuvis-5306RT, Nuvo-3000E/P, Nuvis-3304af and Nuvo-2500E/P

Wide-Temperature Fanless Embedded System

Neosys' exclusive mechanical design and thermal pad efficiently dissipate heat from CPU and other components. It allows Neosys products to operate under 100% CPU loading in a wide temperature environment ranging from -40°C to 70°C.

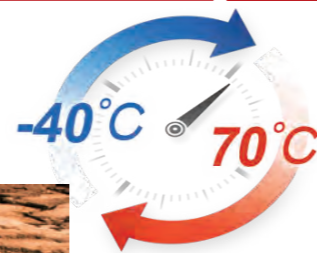

*Available on all products but temperature range may vary

2-16 IEEE 802.3at PoE+ Ports

Supplying up to 25.5W of power per port, Neosys provides 2-16 IEEE 802.3at PoE+ ports for connecting PoE powered device (PD) such as IP cameras, wireless access points or related applications like machine vision, in-vehicle and surveillance. Neosys provide turnkey platforms that offer cost reductions when deploying embedded vision systems.



*Available on Nuvo-5000E/P, Nuvo-5026E, Nuvo-5095GC, Nuvis-5306RT, Nuvo-5100VTC, Nuvo-5608VR, Nuvo-3616VR, POC-351VTC, POC-300, POC-200, Nuvo-3100VTC, PCIe-PoE354at/ 352at, PCIe-PoE550X and PCIe-PoE334LP

DTIO and NuMCU

(R.O.C Patent No. I526834)

Neosys Deterministic Trigger I/O (DTIO) and NuMCU are a MCU-based architecture technology that provides a deterministic timing correlation between input and output signals. It utilizes a standalone microprocessor with highly optimized algorithm to collaborate with platform and DIO circuit. DTIO and NuMCU redefine machine vision systems that require accurate interaction between lighting, camera, actuator and sensor devices.

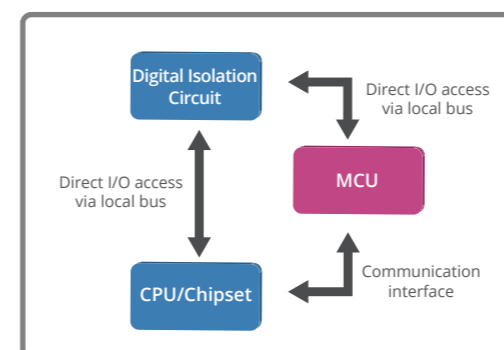

Hardware architecture of DTIO



Innovative approach to implement your own algorithm and create your own unique solution

*Available on Nuvis-530RT, Nuvis-3304af

MezIO™ Module

MezIO™ is the interface designed for incorporating application-oriented I/O functions into an embedded system. It offers computer signals, power rails and control signals via a high-speed connector. MezIO™ module benefits from its 3-point mounted mezzanine structure for mechanical stability.

Neusys MezIO™ modules offer a variety of I/Os such as RS-232/422/485, isolated DIO, CAN bus, ignition power control and DTIO. Users can also leverage signals/ power on MezIO™ interface to create a module with specific domain know-how. The Neusys MezIO™ module presents a cost-effective way to build a tailor-made embedded system for your application.

MEZIO™

Concept of MezIO™ Interface

Neusys MezIO™ (interchangeable mezzanine I/O board) is the interface module designed for incorporating application-oriented I/O functions into an embedded system.

High-speed board-to-board connector

MezIO™ module offers various signals and power rails via a high-speed connector for high-density and high-power applications.

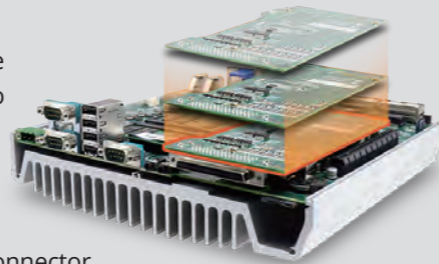

**Available on Nuvo-5000E/P, Nuvo-5026E, Nuvo-5000LP, Nuvo-5095GC, POC-300, POC-120MZ*

Industrial-grade GPU Computing Platform

Featuring Neusys' patented cassette technology and an innovative thermal ventilation design, Neusys products support 75W/ 250W NVIDIA® GPU, it is applicable to CUDA computing, autopilot, deep learning and virtual reality. The system also allows sustained full load operation under -25°C to 60°C wide temperature conditions.

- ▶ Designed for 75W/ 250W NVIDIA® GPU
- ▶ Ideal for open autonomous driving platform
- ▶ A new era for Machine Vision applications
 - > GPU-accelerated Machine Vision library
 - > Deep-learning Machine Vision software



**Available on Nuvo-5095GC, Nuvis-5306RT and Nuvo-6108GC*

Product Selection Guide

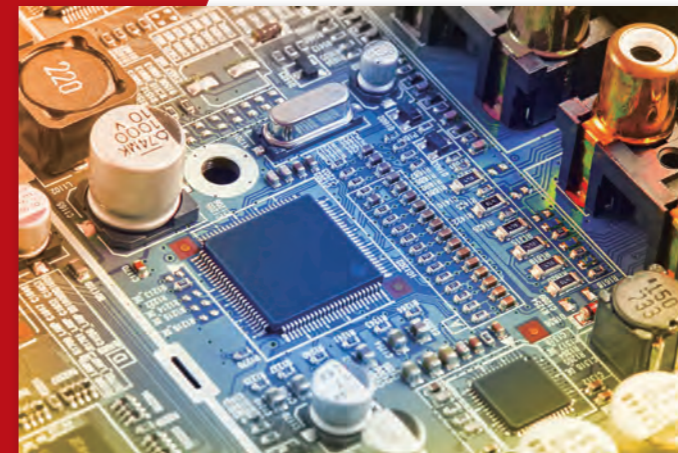

Rugged Embedded Machine Vision In-Vehicle Computing Surveillance/Video Analytics GPU Computing

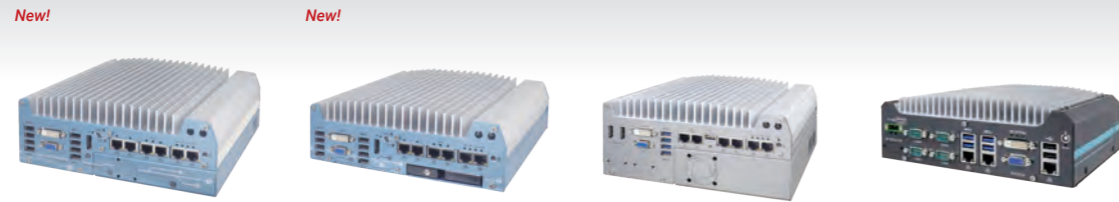

Model Name	Nuvo-7000E/ P/ DE	Nuvo-7000LP	Nuvo-5026E	Nuvo-5501
Dimensions (W x D x H)	240 x 225 x 90 mm(Nuvo-7000E/ P) 240 x 225 x 110.5 mm(Nuvo-7000DE)	240 x 225 x 77 mm	240 x 225 x 111 mm	221 x 173 x 76.2 mm
Weight	3.6 kg(Nuvo-7000E/P) 3.7 kg(Nuvo-7000DE)	3.1 kg	3.7 kg	2.8 kg
Chassis Construction	Aluminum alloy with heavy duty metal	Aluminum alloy with heavy duty metal	Aluminum alloy with heavy duty metal	Aluminum alloy with heavy duty metal
Processor	Intel® Core™ i7-8700/ 8700T Intel® Core™ i5-8500/ 8500T Intel® Core™ i3-8100/ 8100T Intel® Pentium® G5400/ G5400T Intel® Celeron® G4900/G4900T	Intel® Core™ i7-8700/ 8700T Intel® Core™ i5-8500/ 8500T Intel® Core™ i3-8100/ 8100T Intel® Pentium® G5400/ G5400T Intel® Celeron® G4900/G4900T	Intel® Core™ i7-6700/6700TE Intel® Core™ i5-6500/6500TE Intel® Core™ i3-6100/6100TE Intel® Pentium® G4400/G4400TE Intel® Celeron® G3900/G3900TE	Intel® Core™ i7-6700TE Intel® Core™ i5-6500TE Intel® Core™ i3-6100TE Intel® Pentium® G4400TE Intel® Celeron® G3900TE
Chipset	Intel® Q370	Intel® Q370	Intel® Q170	Intel® H110
Graphics	Intel® UHD Graphics 630	Intel® UHD Graphics 630	Intel® HD Graphics 530/ 510	Intel® HD Graphics 530/ 510
Memory	Up to 32 GB DDR4-2666/ 2400	Up to 32 GB DDR4-2666/ 2400	Up to 32 GB DDR4-2133	Up to 16 GB DDR4-2133
PoE	Optional (Port 3-6, IEEE 802.3at, 25.5W)	Optional (Port 3-6, IEEE 802.3at, 25.5W)	Optional (Port 3-6, IEEE 802.3at, 25.5W)	-
Ethernet	6x GbE by Intel® I219 and 5x I210	6x GbE by Intel® I219 and 5x I210	6x GbE by Intel® I219 and 5x I210	1x GbE by Intel® I219-LM 2x GbE by Intel® I210-IT
Video Port	1x VGA 1x DVI-D 1x DisplayPort	1x VGA 1x DVI-D 1x DisplayPort	1x VGA + DVI-D 2x DisplayPort	1x VGA 1x DVI-D
Serial Port	2x RS-232/422/485 2x RS-232	2x RS-232/422/485 2x RS-232	2x RS-232/422/485 1x RS-232	2x RS-232/422/485 2x 3-wire RS-232
USB 2.0	-	-	4	2
USB 3.0	8	8	4	4
Audio	1x Mic-in and speaker-out	1x Mic-in and speaker-out	1x Mic-in and speaker-out	-
Digital I/O	Optional via MeziO™ module	Optional via MeziO™ module	Optional via MeziO™ module	Optional 8 DI + 8 DO
SATA HDD	2x 2.5" HDD/ SSD	1x 2.5" HDD/ SSD 1x Hot-swap tray for 2.5" HDD/SSD	2x 2.5" HDD/ SSD	1x 2.5" HDD/SSD or 1x 3.5" HDD
mSATA / eSATA	1x mSATA (mux. with mini-PCIe)	1x mSATA (mux. with mini-PCIe)	1x mSATA (mux. with mini-PCIe)	1x mSATA
CFast / MicroSD	-	-	-	-
SIM	3	3	2	1
Mini PCI-E	1	1	2	1
M.2	2	2	-	1
MeziO™	Yes	Yes	Yes	-
PCI/PCI Express	1x PCIe x16 slot @ Gen3, 8-lanes PCIe signals in Cassette (Nuvo-7000E) 1x PCI slot in Cassette (Nuvo-7000P) 2x PCIe x8 slots @ Gen3, 4-lanes PCIe signals in Cassette (Nuvo-7000DE)	-	2x PCIe x8 slot @ Gen3, 4-lanes PCIe signals in Cassette	-
DC Input	8-35V DC	8-35V DC	8-35V DC	8-35V DC
Power Consumption	-	-	-	-
Ignition Control	Optional via MeziO™ module	Optional via MeziO™ module	Optional via MeziO™ module	-
Operating Temperature	with 35W CPU -25°C ~ 70°C ** with 65W CPU -25°C ~ 50°C **	with 35W CPU -25°C ~ 70°C ** with 65W CPU -25°C ~ 50°C **	-25°C ~ 70°C ** (i7-6700TE, i5-6500TE, i3-6100TE, Pentium G4400TE [35W TDP]) -25°C ~ 50°C ** (i7-6700, i5-6500, i3-6100 [65W/51W TDP])	-25°C ~ 70°C **
Certification	CE/ FCC	CE/ FCC	CE/ FCC	CE/ FCC
Released Date	2018/6/15	2018/6/15	2017/12/1	2017/11/1
Page Number	P. 20 - 22	P. 23 - 24	P. 25 - 26	P. 27 - 28

* Supports dual display video output
** 100% CPU loading is applied using Intel® Thermal Analysis Tool. For detail testing criteria, please contact Neosys Technology. For sub-zero operating temperature, a wide temperature HDD drive or Solid State Disk (SSD) is required.

Rugged Embedded Machine Vision In-Vehicle Computing Surveillance/Video Analytics GPU Computing



Model Name	Nuvo-5000E/P	Nuvo-5000LP	Nuvo-3000E/P	Nuvo-3005LP
Dimensions (W x D x H)	240 x 225 x 90 mm	240 x 225 x 77 mm	240 x 225 x 90 mm	240 x 225 x 69 mm
Weight	3.6 kg	3.1 kg	4.4 kg	3.4 kg
Chassis Construction	Aluminum alloy with heavy duty metal	Aluminum alloy with heavy duty metal	Aluminum alloy with heavy duty metal	Aluminum alloy with heavy duty metal
Processor	Intel® Core™ i7-6700/6700TE Intel® Core™ i5-6500/6500TE Intel® Core™ i3-6100/6100TE Intel® Pentium® G4400/G4400TE Intel® Celeron® G3900/G3900TE	Intel® Core™ i7-6700/6700TE Intel® Core™ i5-6500/6500TE Intel® Core™ i3-6100/6100TE Intel® Pentium® G4400/G4400TE Intel® Celeron® G3900/G3900TE	Intel® i7-3610QE (2.3/3.3 GHz) Intel® i5-3610ME (2.7/3.3 GHz) Intel® Celeron® 1020E (2.2 GHz)	Intel® i7-3610QE (2.3/3.3 GHz) Intel® i5-3610ME (2.7/3.3 GHz) Intel® Celeron® 1020E (2.2 GHz)
Chipset	Intel® Q170	Intel® Q170	Intel® HM76	Intel® HM76
Graphics	Intel® HD Graphics 530/ 510	Intel® HD Graphics 530/ 510	Intel® HD Graphics 4000 (i7/i5) Intel® HD Graphics (Celeron®)	Intel® HD Graphics 4000 (i7/i5) Intel® HD Graphics (Celeron®)
Memory	Up to 32 GB DDR4-2133	Up to 32 GB DDR4-2133	Up to 16 GB DDR3-1600	Up to 16 GB DDR3-1600
PoE	Optional (Port 3-6, IEEE 802.3at, 25.5W)	Optional (Port 3-6, IEEE 802.3at, 25.5W)	Optional (4 ports, IEEE 802.3af, 15.4W)	Optional (4 ports, IEEE 802.3af, 15.4W)
Ethernet	2x GbE by Intel® I219 and I210 (5002E/P) 6x GbE by Intel® I219 and 5x I210 (5006E/P)	2x GbE by Intel® I219 and I210 (5002LP) 6x GbE by Intel® I219 and 5x I210 (5006LP)	5x GbE by Intel® I210 (3005E/P) 3x GbE by Intel® I210 (3003E/P)	5x GbE by Intel® I210 (3005LP)
Video Port	1x VGA + DVI-D 2x DisplayPort	1x VGA + DVI-D 2x DisplayPort	1x VGA* 2x DVI-D	1x VGA* 2x DVI-D
Serial Port	2x RS-232/422/485 1x RS-232	2x RS-232/422/485 1x RS-232	2x RS-232/422/485	1 x RS-232/422/485
USB 2.0	4	4	4	2
USB 3.0	4	4	4	2
Audio	1x Mic-in and speaker-out	1x Mic-in and speaker-out	1x Mic-in and speaker-out	1x Mic-in and speaker-out
Digital I/O	Optional via MeziO™ module	Optional via MeziO™ module	Optional 8 DI + 8 DO Polling, COS	Optional 8 DI + 8 DO Polling, COS
SATA HDD	2x 2.5" HDD/ SSD	1x 2.5" HDD/ SSD 1x Hot-swap tray for 2.5" HDD/SSD	1x 2.5" HDD/SSD	1x 2.5" HDD/SSD 1x easy-swap tray for 2.5" HDD/SSD
mSATA / eSATA	1x mSATA (mux. with mini-PCIe)	1x mSATA (mux. with mini-PCIe)	-	-
CFast / MicroSD	-	-	1x CFast	1x CFast
SIM	2	2	1	1
Mini PCI-E	2	2	2	2
M.2	-	-	-	-
MeziO™	Yes	Yes	-	-
PCI/PCI Express	1x PCI slot in Cassette (Nuvo-5002P/5006P) 1x PCIe x16 slot @ Gen3, 8-lanes PCIe signals in Cassette (Nuvo-5002E/5006E)	-	1x PCI Express x16 slot (3000E) 1x 33MHz/32-bit PCI slot (3000P)	-
DC Input	8-35V DC	8-35V DC	8-25V DC	8-25V DC
Power Consumption	-	-	with i7 : 72.96W (3.84A@19V) with i5 : 48.83W (2.57A@19V)	with i7 : 72.96W (3.84A@19V) with i5 : 48.83W (2.57A@19V)
Ignition Control	Optional via MeziO™ module	Optional via MeziO™ module	Optional	Optional
Operating Temperature	-25°C ~ 70°C ** (i7-6700TE, i5-6500TE, i3-6100TE, Pentium G4400TE [35W TDP]) -25°C ~ 50°C ** (i7-6700, i5-6500, i3-6100 [65W/51W TDP])	-25°C ~ 70°C ** (i7-6700TE, i5-6500TE, i3-6100TE, Pentium G4400TE [35W TDP]) -25°C ~ 50°C ** (i7-6700, i5-6500, i3-6100 [65W/51W TDP])	-25°C ~ 70°C ** (i5-3610ME & Celeron 1020E) -25°C ~ 60°C ** (i7-3610QE)	-25°C ~ 70°C ** (i5-3610ME & Celeron 1020E) -25°C ~ 60°C ** (i7-3610QE)
Certification	CE/ FCC	CE/ FCC	CE/ FCC	CE/FCC
Released Date	2015/12/1	2015/12/1	2013/6/1	2013/10/15
Page Number	P. 29 - 30	P. 31 - 32	P. 33 - 34	P. 35 - 36

* Supports dual display video output
** 100% CPU loading is applied using Intel® Thermal Analysis Tool. For detail testing criteria, please contact Neosys Technology. For sub-zero operating temperature, a wide temperature HDD drive or Solid State Disk (SSD) is required.

Selection Guide

Rugged Embedded Machine Vision In-Vehicle Computing Surveillance/Video Analytics GPU Computing



Model Name	Nuvo-3000TB	Nuvo-3120	Nuvo-2500E/P	Nuvo-6000		
Chassis	Dimensions (W x D x H)	240 x 225x 86 mm	212 x 165 x 62 mm	205 x 146 x 76 mm		
	Weight	3.4 kg	2.7 kg	2.3 kg		
	Chassis Construction	Aluminum alloy with heavy duty metal	Aluminum alloy with heavy duty metal	Aluminum alloy with heavy duty metal	Aluminum alloy with heavy duty metal	
System	Processor	Intel® i7-3610QE (2.3/3.3 GHz) Intel® i5-3610ME (2.7/3.3 GHz) Intel® Celeron® 1020E (2.2 GHz)	Intel® i7-3610QE (2.3/3.3 GHz) Intel® i5-3610ME (2.7/3.3 GHz) Intel® Celeron® 1020E (2.2 GHz)	Intel® Celeron® J1900 quad-core	Intel® Core™ i7-6700TE Intel® Core™ i5-6500TE Intel® Core™ i3-6100TE Intel® Pentium® G4400TE Intel® Celeron® G3900TE	
	Chipset	Intel® HM76	Intel® HM76	-	Intel® H110	
	Graphics	Intel® HD Graphics 4000 (i7/i5) Intel® HD Graphics (Celeron®)	Intel® HD Graphics 4000 (i7/i5) Intel® HD Graphics (Celeron®)	Intel® HD Graphics	Intel® HD Graphics 530/ 510	
	Memory	Up to 16 GB DDR3-1600	Up to 8 GB DDR3-1600	Up to 8 GB DDR3L-1333	Up to 16 GB DDR4-2133	
	PoE	Optional (4 ports, IEEE 802.3af, 15.4W)	-	-	-	
I/O Interface	Ethernet	5x GbE by Intel® I210 (3005TB) 3x GbE by Intel® I210 (3003TB)	1x GbE by Intel® 82579LM 1x GbE by Intel® i210	2x GbE by Intel® I210	1x GbE by Intel® I219-LM 1x GbE by Intel® I210-IT	
	Video Port	1x VGA* 2x DVI-D	1x DVI-I 2x DisplayPort	1x VGA 1x DVI-D	2x DVI-D	
	Serial Port	2x RS-232/422/485	2x RS-232/422/485	2x RS-232/422/485 2x RS-232	2x RS-232/422/485 3x 3-wire RS-232	
	USB 2.0	4	2	3	-	
	USB 3.0	4	4	1	4	
	Audio	1x Mic-in and Speaker-out	1x Mic-in and speaker-out	1x Mic-in and speaker-out	1x speaker-out	
	Digital I/O	Optional 8 DI + 8 DO Polling, COS	4 DI + 4 DO Polling, COS	Optional Auxiliary I/O (4 DI, 8 DO, 6 PWM, 1 encoder, 2 ADC)	-	
	Storage Interface	SATA HDD	1x 2.5" HDD/SSD 1x 3.5" HDD	1x 2.5" HDD/SSD	1x 2.5" HDD/SSD	3x 2.5" HDD/SSD (Nuvo-6032) 1x 2.5" HDD/SSD (Nuvo-6002)
		mSATA / eSATA	-	1x mSATA	1x mSATA	1x mSATA
		CFast / MicroSD	1x CFast	-	-	-
SIM		1	2	1	-	
Mini PCI-E		2	2	2	-	
Expansion Bus	M.2	-	-	-	-	
	MezIO™	-	-	-	-	
	PCI/PCI Express	-	-	1x 33MHz/32-bit PCI slot (Nuvo-2500P) 1x PCI Express x4 slot (Nuvo-2500E)	1x PCI Express x16 slot 1x PCI Express x8 slot 3x 33MHz/32-bit PCI slots (Nuvo-6032)	
Power Supply	DC Input	8-25V DC	8-35V DC	8-35V DC	8-35V DC	
	Power Consumption	with i7 : 72.96W (3.84A@19V) with i5 : 48.83W (2.57A@19V)	With i7 : 15.6W (3.45A@19V)* With i5 : 43.9W (2.31A@19V)*	-	-	
	Ignition Control	Optional	-	-	-	
Environmental	Operating Temperature	-25°C ~ 70°C ** (i5-3610ME & Celeron 1020E) -25°C ~ 60°C** (i7-3610QE)	i7-3610QE, 100% CPU loading* Maximal Perf. -25°C ~ 50°C** Reduced Perf. -25°C ~ 60°C** Extended Temp. -25°C ~ 70°C** i5-3610ME, 100% CPU loading* Maximal Perf. -25°C ~ 60°C** Reduced Perf. -25°C ~ 70°C** Extended Temp. -25°C ~ 70°C**	-25°C ~ 70°C **	-25°C ~ 60°C **	
	Certification	CE/FCC	CE/FCC	CE/FCC	CE/FCC	
Released Date	2013/6/1	2014/5/15	2015/2/1	2016/6/1		
Page Number	P. 37 - 38	P. 39 - 40	P. 41 - 42	P. 43 - 44		

Rugged Embedded Machine Vision In-Vehicle Computing Surveillance/Video Analytics GPU Computing



Model Name	Nuvo-4000	Nuvo-2400	POC-300	POC-200		
Chassis	Dimensions (W x D x H)	164 x 225 x 180 mm	139 x 160 x 225 mm	56 x 108 x 153 mm	149 x 105 x 57 mm	
	Weight	4.0 kg	2.2 kg	0.96 kg	1.1 kg	
	Chassis Construction	Aluminum alloy with heavy duty metal	Aluminum alloy with heavy duty metal	Aluminum alloy with heavy duty metal	Aluminum alloy with heavy duty metal	
System	Processor	Intel® i7-3610QE (2.3/ 3.3 GHz) Intel® i5-3610ME (2.7/ 3.3 GHz) Intel® Celeron® 1020E (2.2 GHz)	Intel® Celeron® J1900 quad-core	Intel® Atom™ E3950 quad-core Intel® Pentium® N4200 quad-core	Intel® Atom™ E3845 quad-core Intel® Atom™ E3825 dual-core	
	Chipset	Intel® HM76	-	-	-	
	Graphics	Intel® HD Graphics 4000 (i7/i5) Intel® HD Graphics (Celeron)	Intel® HD Graphics	Intel® HD Graphics 505	Intel® HD Graphics	
	Memory	Up to 16 GB DDR3-1600	Up to 8GB DDR3L-1333	Up to 8GB DDR3L-1866	Up to 8GB DDR3L-1333	
	PoE	-	-	IEEE 802.3at (25.5W) for 2 GbE ports	IEEE 802.3at (25.5W) for 2 GbE ports	
I/O Interface	Ethernet	2x GbE by Intel® I210	2x GbE by Intel® I210	3x GbE by Intel® i210	2x GbE by Intel® I210	
	Video Port	1x DVI-I 1x DVI-D	1x DVI-I	1x DVI-I	1x DVI-I	
	Serial Port	2x RS-232/422/485 1x RS-232	2x RS-232/422/485 2x RS-232	1x RS-232/422/485 3x 3-wire RS-232	2x RS-232/422/485 2x RS-232	
	USB 2.0	-	3	2	1	
	USB 3.0	4	1	2	3	
	Audio	1x speaker-out	1x Mic-in and speaker-out	1x Mic-in and speaker-out	1x Speaker-out	
	Digital I/O	Optional 8 DI + 8 DO Polling, COS	Optional 8 DI + 8 DO Polling	-	Optional 4 DI + 4 DO Polling	
	Storage Interface	SATA HDD	2x 2.5" HDD/SSD	2x 2.5" HDD/SSD	-	1x 2.5" HDD/SSD
		mSATA / eSATA	-	-	1x mSATA	-
		CFast / MicroSD	1x CFast	-	-	-
SIM		-	-	1	1	
Mini PCI-E		-	-	1	1	
Expansion Bus	M.2	-	-	-	-	
	MezIO™	-	-	Yes	-	
	PCI/PCI Express	1x PCI Express x16 slot 1x PCI Express x4 slot 2x 33MHz/32-bit PCI slots (Nuvo-4022) or 4x 33MHz/32-bit PCI slots (Nuvo-4040)	1x PCI Express x4 slot 2x 33MHz/32-bit PCI slots (Nuvo-2421) or 3x 33MHz/32-bit PCI slots (Nuvo-2430)	-	-	
Power Supply	DC Input	8-25V DC	8-25V DC	8-35V DC	8-35V DC	
	Power Consumption	With i7: 66.12W (3.48A@19V)* With i5 : 43.13W (2.27A@19V)*	-	-	Typical: 7.68W (0.32A@24V) Full-loading: 13.44W (0.56A@24V)*	
	Ignition Control	-	-	Optional via MezIO™ module	-	
Environmental	Operating Temperature	-25°C ~ 60°C **	-25°C ~ 70°C **	-25°C ~ 70°C **	-25°C ~ 70°C**	
	Certification	CE/FCC	CE/FCC	CE/FCC	CE/FCC	
Released Date	2013/11/1	2015/9/15	2017/5/1	2014/5/1		
Page Number	P. 45 - 46	P. 47 - 48	P. 51 - 52	P. 53 - 54		

11 * Supports dual display video output
** 100% CPU loading is applied using Intel® Thermal Analysis Tool. For detail testing criteria, please contact Neosys Technology. For sub-zero operating temperature, a wide temperature HDD drive or Solid State Disk (SSD) is required.
All rights reserved. Copyright© 2018 Neosys Technology, Inc.

12 * Supports dual display video output
** 100% CPU loading is applied using Intel® Thermal Analysis Tool. For detail testing criteria, please contact Neosys Technology. For sub-zero operating temperature, a wide temperature HDD drive or Solid State Disk (SSD) is required.
All specifications and photos are subject to change without prior notice

Rugged Embedded Machine Vision In-Vehicle Computing Surveillance/Video Analytics GPU Computing



Model Name	POC-120	IGT-20	Nuvis-5306RT	Nuvis-3304af		
Chassis	Dimensions (W x D x H)	149 x 105 x 34 mm	41 x 77 x 104 mm	240 x 225 x 111 mm		
	Weight	0.9 kg	0.4 kg	4.5 kg		
	Chassis Construction	Aluminum alloy with heavy duty metal	Heavy duty metal	Aluminum alloy with heavy duty metal	Aluminum alloy with heavy duty metal	
System	Processor	Intel® Atom™ E3826 dual-core	TI Sitara AM3352 1 GHz Processor	Intel® Core™ i7-6700/6700TE Intel® Core™ i5-6500/6500TE		
	Chipset	-	-	Intel® Q170		
	Graphics	Intel® HD Graphics	-	Intel® HD Graphics 530	Intel® HD Graphics 4000	
	Memory	Up to 8 GB DDR3L-1067	1GB DDR3L-1333	Up to 32 GB DDR4-2133	Up to 16 GB DDR3-1600	
	PoE	-	-	Optional (Port 3-6, IEEE 802.3at, 25.5W)	IEEE 802.3af (15.4W) for 4 GbE ports	
I/O Interface	Ethernet	2x GbE by Intel® I210	1x 10/100M Ethernet	6x GbE by Intel® I219 and 5x I210		
	Video Port	1x VGA	-	1x VGA + DVI-D 2x DisplayPort	1x VGA* 2x DVI-D	
	Serial Port	1x RS-232/422/485 1x RS-232	2x RS-232/422/485	2x RS-232/422/485 1x RS-232	2x RS-232/422/485	
	USB 2.0	2	1	4	4	
	USB 3.0	1	-	4	4	
	Audio	1x Speaker-out	-	1x Mic-in and speaker-out	1x Mic-in and speaker-out	
	Digital I/O	Optional by MeziO™ module	4 DI + 4 DO	8 DI + 8 DO Polling, COS, DTIO V2	8 DI + 8 DO Polling, COS, DTIO	
	Storage Interface	SATA HDD	-	-	2x 2.5" HDD/SSD	
		mSATA / eSATA	1x mSATA	-	1x mSATA (mux. with mini-PCIe)	-
		CFast / MicroSD	-	2x MicroSD	-	1x CFast
SIM		-	1	2	1	
Expansion Bus	Mini PCI-E	-	1	2		
	M.2	-	-	-		
	MeziO™	Yes	-	-		
Power Supply	DC Input	8-35V DC	8-25V DC	8-35V DC		
	Power Consumption	-	-	-		
Environmental	Operating Temperature	-25°C ~ 70°C**	-25°C ~ 70°C **	-25°C ~ 60°C ** (i7-6700TE, i5-6500TE [35W TDP]) -25°C ~ 50°C ** (i7-6700, i5-6500, i3-6100 [65W/51W TDP])		
	Certification	CE/FCC	CE/FCC	CE/FCC		
Released Date	2015/3/1	2017/3/1	2017/3/1	2013/10/1		
Page Number	P. 55 - 56	P. 59 - 60	P. 61 - 62	P. 63 - 64		

Rugged Embedded Machine Vision In-Vehicle Computing Surveillance/Video Analytics GPU Computing



Model Name	Nuvo-7160GC	Nuvo-6108GC-IGN	Nuvo-6108GC	Nuvo-5095GC		
Chassis	Dimensions (W x D x H)	240 x 225 x 111 mm	178 x 360 x 174 mm	164 x 360 x 174 mm		
	Weight	4.5 kg	4.7 kg	4.7 kg		
	Chassis Construction	Aluminum alloy with heavy duty metal	Aluminum alloy with heavy duty metal	Aluminum alloy with heavy duty metal	Aluminum alloy with heavy duty metal	
System	Processor	Intel® Core™ i7-8700/ 8700T Intel® Core™ i5-8500/ 8500T Intel® Core™ i3-8100/ 8100T Intel® Pentium® G5400/ G5400T Intel® Celeron® G4900/G4900T	Intel® Xeon™ Processor E3-1275 v5 Intel® Xeon™ Processor E3-1268L v5 Intel® Core™ i7- 6700/6700TE Intel® Core™ i5- 6500/6500TE	Intel® Xeon™ Processor E3-1275 v5 Intel® Xeon™ Processor E3-1268L v5 Intel® Core™ i7- 6700/6700TE Intel® Core™ i5- 6500/6500TE	Intel® Core™ i7-6700/6700TE Intel® Core™ i5-6500/6500TE	
	Chipset	Intel® Q370	Intel® C236	Intel® C236	Intel® Q170	
	Graphics	Intel® UHD Graphics 630	x16 PEG port, or Intel® HD Graphics 530	x16 PEG port, or Intel® HD Graphics 530	NVIDIA® GeForce® Intel® HD Graphics 530	
	Memory	Up to 32 GB DDR4-2666/ 2400	Up to 32 GB DDR4-2133	Up to 32 GB DDR4-2133	Up to 32 GB DDR4-2133	
	PoE	Optional (Port 3-6, IEEE 802.3at, 25.5W)	-	-	Optional (Port 3-6, IEEE 802.3at, 25.5W)	
I/O Interface	Ethernet	6x GbE by Intel® I219 and 5x I210	1x GbE by Intel® I219-LM 1x GbE by Intel® I210-IT	1x GbE by Intel® I219-LM 1x GbE by Intel® I210-IT	6x GbE by Intel® I219 and 5x I210	
	Video Port	1x VGA 1x DVI-D 1x DisplayPort	2x DVI-D	2x DVI-D	1x VGA + DVI-D 2x DisplayPort	
	Serial Port	2x RS-232/422/485 2x RS-232	2x RS-232/422/485	2x RS-232/422/485	2x RS-232/422/485 1x RS-232	
	USB 2.0	-	-	-	4	
	USB 3.0	8	4	4	4	
	Audio	1x Mic-in and speaker-out	1x Speaker-out	1x Speaker-out	1x Mic-in and Speaker-out	
	Digital I/O	Optional via MeziO™ module	-	-	Optional by MeziO™ module	
	Storage Interface	SATA HDD	2x 2.5" HDD/ SSD	4x 2.5" HDD/SSD	4x 2.5" HDD/SSD	2x 2.5" HDD/SSD
		mSATA / eSATA	1x mSATA (mux. with mini-PCIe)	-	-	1x mSATA (mux. with mini-PCIe)
		CFast / MicroSD	-	-	-	-
SIM		3	-	-	2	
Expansion Bus	Mini PCI-E	1	1	1	2	
	M.2	2	1	1	-	
	MeziO™	Yes	-	-	Yes	
Power Supply	DC Input	8-35V DC	24V DC	24V DC	8-35V DC	
	Power Consumption	-	-	-	-	
Environmental	Operating Temperature	with 35W CPU and 120W GPU -25°C ~ 60°C ** with 65W CPU and 120W GPU -25°C ~ 60°C ** (35W TDP) -25°C ~ 50°C ** (65W TDP)	-25°C ~ 60°C **	-25°C ~ 60°C **	-25°C ~ 60°C ** (i7-6700TE, i5-6500TE [35W TDP]) -25°C ~ 50°C ** (i7-6700, i5-6500, i3-6100 [65W/51W TDP])	
	Certification	CE/ FCC	CE/FCC	CE/FCC	CE/FCC	
Released Date	2018/8/15	2018/6/1	2017/8/1	2016/12/1		
Page Number	P. 87 - 88	P. 89 - 90	P. 91 - 92	P. 93 - 94		

13 * Supports dual display video output
** 100% CPU loading is applied using Intel® Thermal Analysis Tool. For detail testing criteria, please contact Neosys Technology. For sub-zero operating temperature, a wide temperature HDD drive or Solid State Disk (SSD) is required.
All rights reserved. Copyright© 2018 Neosys Technology, Inc.

14 * Supports dual display video output
** 100% CPU loading is applied using Intel® Thermal Analysis Tool. For detail testing criteria, please contact Neosys Technology. For sub-zero operating temperature, a wide temperature HDD drive or Solid State Disk (SSD) is required.
All specifications and photos are subject to change without prior notice

Selection Guide

Rugged Embedded Machine Vision In-Vehicle Computing Surveillance/Video Analytics GPU Computing



Model Name	POC-351VTC	Nuvo-5100VTC	Nuvo-2510VTC	Nuvo-3100VTC	
Chassis	Dimensions (W x D x H)	56 x 108 x 153 mm	240 x 225 x 79 mm	205 x 146 x 44 mm	
	Weight	0.96 kg	3.3 kg	1.9 kg	
	Chassis Construction	Aluminum alloy with heavy duty metal	Aluminum alloy with heavy duty metal	Aluminum alloy with heavy duty metal	Aluminum alloy with heavy duty metal
System	Processor	Intel® Atom™ E3950 quad-core Intel® Pentium® N4200 quad-core	Intel® Core™ i7-6700TE Intel® Core™ i5-6500TE Intel® Core™ i3-6100TE	Intel® Atom™ E3845 quad-core	Intel® i7-3610QE (2.3/3.3 GHz) Intel® i5-3610ME (2.7/3.3 GHz) Intel® Celeron® 1020E (2.2 GHz)
	Chipset	-	Intel® Q170	-	Intel® QM77
	Graphics	Intel® HD Graphics 505	Intel® HD Graphics 530	Intel® HD Graphics	Intel® HD Graphics 4000 (i7/i5) Intel® HD Graphics (Celeron)
	Memory	Up to 8GB DDR3L-1866	Up to 32 GB DDR4-2133	Up to 8GB DDR3L-1333	Up to 8GB DDR3-1600
	PoE	IEEE 802.3at (25.5W) for 2 GbE ports	IEEE 802.3at (25.5W) for 4 GbE ports, M12 x-coded connector	IEEE 802.3at (25.5W) for 2 GbE ports	IEEE 802.3at (25.5W) for 4 GbE ports
I/O Interface	Ethernet	3x GbE by Intel® I210	2x GbE by Intel® I219 and I210	2x GbE by Intel® I210	1x GbE by Intel® 82579LM 3x GbE by Intel® i210
	Video Port	1x DVI-I	1x VGA + DVI-D 2x DisplayPort	1x VGA 1x DVI-D	1x DVI-I 2x DisplayPort
	Serial Port	1x RS-232/422/485 3x 3-wire RS-232	2x RS-232/422/485 1x RS-232	2x RS-232/422/485 2x RS-232	2x RS-232/422/485
	USB 2.0	2	4	3	2
	USB3.0	2	4	1	4
	Audio	1x Mic-in and speaker-out	1x Mic-in and speaker-out	1x Mic-in and speaker-out	1x Mic-in and speaker-out
	Digital I/O	4 DI + 4 DO Polling, COS	4 DI + 4 DO Polling, COS	-	4 DI + 4 DO Polling, COS
	SATA HDD	-	1x 2.5" HDD/SSD 1x Hot-swap tray for 2.5" HDD/SSD	1x 2.5" HDD/SSD	1x 2.5" HDD/SSD 1x easy-swap tray for 2.5" HDD/SSD
	mSATA / eSATA	2x mSATA	1x mSATA (mux. with mini-PCIe)	1x mSATA	1x mSATA
	CFast / MicroSD	-	-	-	-
Expansion Bus	SIM	4	4	2	2
	Mini PCI-E	3	4	2	2
	M.2	1	-	-	-
	MezIO™	-	-	-	-
Power Supply	DC Input	8-35V DC	8-35V DC	8-35V DC	8-35V DC
	Power Consumption	-	-	-	With i7 : 68.8W (3.62A@19V) With i5 : 46.9W (2.47A@19V)
	Ignition Control	Built-in	Built-in	Built-in	Built-in
Environmental	Operating Temperature	-25°C ~ 70°C **	-40°C ~ 70°C **	-25°C ~ 70°C **	i7-3610QE, 100% CPU loading* Maximal Perf. -25°C ~ 50°C** Reduced Perf. -25°C ~ 60°C** Extended Temp. -25°C ~ 70°C** i5-3610ME, 100% CPU loading* Maximal Perf. -25°C ~ 60°C** Reduced Perf. -25°C ~ 70°C** Extended Temp. -25°C ~ 70°C**
	Certification	E-Mark, CE/FCC	E-Mark, EN50155, CE/ FCC	E-Mark, CE/ FCC	E-Mark, EN50155, CE/ FCC
Released Date	2018/1/1	2016/6/1	2015/2/1	2014/5/1	
Page Number	P. 71 - 72	P. 73 - 74	P. 75 - 76	P. 77 - 78	

* Supports dual display video output
** 100% CPU loading is applied using Intel® Thermal Analysis Tool. For detail testing criteria, please contact Neosys Technology. For sub-zero operating temperature, a wide temperature HDD drive or Solid State Disk (SSD) is required.
*** Depending on the HDD selected, users may encounter performance degradation in sequential disk write at low/high ambient temperature. No data integrity issue was observed in -10°C ~ 60°C operating temperature range.
All rights reserved. Copyright© 2018 Neosys Technology, Inc.

Rugged Embedded Machine Vision In-Vehicle Computing Surveillance/Video Analytics GPU Computing

Coming soon!



Model Name	Nuvo-7100VTC	Nuvo-5608VR	Nuvo-3616VR	iVIS-200	
Chassis	Dimensions (W x D x H)	240 x 225 x 77 mm	240 x 225 x 98 mm	240 x 225 x 90 mm	
	Weight	3.1 kg	3.5 kg	4.4 kg	
	Chassis Construction	Aluminum alloy with heavy duty metal	Aluminum alloy with heavy duty metal	Aluminum alloy with heavy duty metal	Aluminum alloy
System	Processor	Intel® Core™ i7-8700/ 8700T Intel® Core™ i5-8500/ 8500T Intel® Core™ i3-8100/ 8100T Intel® Pentium® G5400/ G5400T Intel® Celeron® G4900/G4900T	Intel® Core™ i7-6700/6700TE Intel® Core™ i5-6500/6500TE Intel® Core™ i3-6100/6100TE	Intel® i7-3610QE (2.3/3.3 GHz) Intel® i5-3610ME (2.7/3.3 GHz) Intel® Celeron® 1020E (2.2 GHz)	Intel® Atom™ E3845 quad-core
	Chipset	Intel® Q370	Intel® Q170	Intel® HM76	-
	Graphics	Intel® UHD Graphics 630	Intel® HD Graphics 530	Intel® HD Graphics 4000 (i7/i5) Intel® HD Graphics (Celeron®)	Intel® HD Graphics
	Memory	Up to 32 GB DDR4-2666/ 2400	Up to 32 GB DDR4-2133	Up to 16 GB DDR3-1600	Up to 8 GB DDR3L-1333
	PoE	IEEE 802.3at (25.5W) for 4 GbE ports, M12 x-coded connector	8x IEEE 802.3at(25.5W) PoE+ by Intel® I210,	Optional (4 ports, IEEE 802.3af, 15.4W)	-
I/O Interface	Ethernet	6x GbE by Intel® I219 and 5x I210	2x GbE by Intel® I219 and I1210	5x GbE by Intel® I210 (3005E/P) 3x GbE by Intel® I210 (3003E/P)	1x GbE by Intel® I210
	Video Port	1x VGA 1x DVI-D 1x DisplayPort	1x VGA + DVI-D 2x DisplayPort	1x VGA* 2x DVI-D	1x VGA
	Serial Port	2x RS-232/422/485 2x RS-232	2x RS-232/422/485 1x RS-232	2x RS-232/422/485	1 x RS232
	USB 2.0	-	4	4	1
	USB3.0	8	4	4	-
	Audio	1x Speaker-out	1x Mic-in and speaker-out	1x Mic-in and speaker-out	-
	Digital I/O	4 DI + 4 DO Polling, COS	4 DI + 4 DO Polling, COS	Optional 8 DI + 8 DO Polling, COS	-
	SATA HDD	1x 2.5" HDD/ SSD 1x Hot-swap tray for 2.5" HDD/SSD	2x 3.5" HDD/ SSD	1x 2.5" HDD/SSD	-
	mSATA / eSATA	1x mSATA (mux. with mini-PCIe)	1x mSATA (mux. with mini-PCIe)	-	1x mSATA
	CFast / MicroSD	-	-	1x CFast	-
Expansion Bus	SIM	2	4	1	-
	Mini PCI-E	2	4	2	1
	M.2	2	-	-	-
	MezIO™	Yes	-	-	-
Power Supply	DC Input	8-35V DC	8-35V DC	8-35V DC	12/24V DC
	Power Consumption	-	-	with i7 : 72.96W (3.84A@19V) with i5 : 48.83W (2.57A@19V)	-
	Ignition Control	Optional via MezIO™ module	-	Optional	-
Environmental	Operating Temperature	with 35W CPU -25°C ~ 70°C **	-25°C ~ 70°C (with mSATA/SSD) ** -10°C ~ 60°C (with 3.5" HDD) **/***	-25°C ~ 70°C ** (i5-3610ME & Celeron 1020E) -25°C ~ 60°C ** (i7-3610QE)	-25°C ~ 60°C **
	Certification	CE/ FCC	CE/FCC	CE/FCC	CE/FCC
Released Date	Coming Soon	2018/2/1	2013/6/1	2013/10/15	
Page Number	P. 79 - 80	P. 81 - 82	P. 83 - 84	P. 65 - 66	

* Supports dual display video output
** 100% CPU loading is applied using Intel® Thermal Analysis Tool. For detail testing criteria, please contact Neosys Technology. For sub-zero operating temperature, a wide temperature HDD drive or Solid State Disk (SSD) is required.
All specifications and photos are subject to change without prior notice.



Neousys Intelligent Embedded Systems



- ▼ Rugged Embedded
- ▼ Machine Vision
- ▼ In-Vehicle Computing
- ▼ Surveillance / Video Analytics
- ▼ GPU Computing

Nuvo-7000E/ 7000DE/ 7000P Series

Intel® 8th-Gen Coffee Lake Core™ i7/ i5/ i3 Fanless Controller with 6x GbE Ports, Patented Cassette and MezIO™ Interface



CE FC

*R.O.C Patent No. M456527

Key Features

- Intel® 8th-Gen Core™ i hexa-core 35W/ 65W LGA1151 CPU
- Patented Cassette for PCI/PCIe add-on card accommodation*
- MezIO™ interface for easy function expansion
- Rugged, -25°C to 70°C fanless operation
- Up to 6x GigE ports, supporting 9.5 KB jumbo frame
- M.2 2280 M key socket (Gen3 x4) supporting NVMe SSD or Intel® Optane™ memory
- 4x USB 3.1 Gen2 ports and 4x USB 3.1 Gen1 ports
- VGA/ DVI/ DP triple independent display, supporting 4K2K resolution

Introduction

Introducing Neosys Technology's 2018 flagship rugged fanless controllers, the new Nuvo-7000 series, powered by Intel® 8th-Gen Core™ i processors with up to 6-core/ 12-thread architecture that offer significant performance improvement over previous 6th and 7th-Gen platforms. Nuvo-7000 series includes Neosys' track-proven technologies for superior ruggedness and versatility, such as effective fanless design, patented expansion Cassette and proprietary MezIO™ interface. It also incorporates cutting-edge computer I/O like USB 3.1 Gen2 with up to 10 Gbps throughput and M.2 2280 M key socket for NVMe SSD or Intel® Optane™ memory for ultimate system performance. The plethora of on-board I/O ports (GbE, USB and COM) feature sophisticated protection circuits to endure stress from ESD and power surge. This makes Nuvo-7000 series by far the most rock-solid embedded controller we've ever created.

Flexible and versatile for a variety of applications, Nuvo-7000 variants are available with different Cassette expansion options. With Neosys Nuvo-7000 series, you get a true rugged platform that can accommodate a single PCIe card (Nuvo-7000E), dual PCIe cards (Nuvo-7000DE) or a single PCI card (Nuvo-7000P) according your application needs.

Specifications

System Core	Expansion Bus
Processor Supporting Intel® 8th-Gen Coffee Lake CPU (LGA1151 socket, 35W/ 65W TDP) - Intel® Core™ i7-8700/ i7-8700T - Intel® Core™ i5-8500/ i5-8500T - Intel® Core™ i3-8100/ i3-8100T - Intel® Pentium® G5400/ G5400T - Intel® Celeron® G4900/ G4900T	PCI/PCI Express 1x PCIe x16 slot@Gen3, 8-lanes PCIe signals in Cassette (Nuvo-7002E/ 7006E) 2x PCIe x8 slots@Gen3, 4-lanes PCIe signals in Cassette (Nuvo-7002DE/ 7006DE) 1x PCI slot in Cassette (Nuvo-7002P/ 7006P)
Chipset Intel® Q370 Platform Controller Hub	Mini PCI Express 1x full-size mini PCI Express socket with internal SIM socket (mux with mSATA)
Graphics Integrated Intel® UHD Graphics 630	M.2 1x M.2 2242 B key socket with dual front-accessible SIM sockets, supporting dual SIM mode with selected M.2 LTE module
Memory Up to 32 GB DDR4 2666/ 2400 SDRAM (two SODIMM slots)	Expandable I/O 1x MezIO™ expansion port for Neosys MezIO™ modules
AMT Supports AMT 12.0	Power Supply
TPM Supports TPM 2.0	DC Input 1x 3-pin pluggable terminal block for 8-35VDC input
I/O Interface	Remote Ctrl. & LED Output 1x 3-pin pluggable terminal block for remote control and PWR LED output
Ethernet 2x Gigabit Ethernet ports by I219 and I210 (Nuvo-7002E/ P/ DE) 6x Gigabit Ethernet ports by I219 and 5x I210 (Nuvo-7006E/ P/ DE)	Mechanical
PoE+ Optional IEEE 802.3at PoE+ PSE for Port 3 ~ Port 6 100 W total power budget	Dimension 240 mm (W) x 225 mm (D) x 90 mm (H) (Nuvo-7000E/ P series) 240 mm (W) x 225 mm (D) x 110.5 mm (H) (Nuvo-7000DE series)
USB 4x USB 3.1 Gen2 (10 Gbps) ports 4x USB 3.1 Gen1 (5 Gbps) ports	Weight 3.58 kg (Nuvo-7000E/ P series) 3.7 kg (Nuvo-7000DE series)
Video Port (Integrated Graphics) 1x VGA connector, supporting 1920 x 1200 resolution 1x DVI-D connector, supporting 1920 x 1200 resolution 1x DisplayPort connector, supporting 4096 x 2304 resolution	Mounting Wall-mounting (standard) or DIN-Rail mounting (optional)
Serial Port 2x software-programmable RS-232/ 422/ 485 ports (COM1/ COM2) 2x RS-232 ports (COM3/ COM4)	Environmental
Audio 1x 3.5 mm jack for mic-in and speaker-out	Operating Temperature with 35W CPU -25°C ~ 70°C ** with 65W CPU -25°C ~ 70°C *** (configured as 35W TDP) -25°C ~ 50°C *** (configured as 65W TDP)
Storage Interface	Storage Temperature -40°C ~ 85°C
SATA HDD 2x internal SATA port for 2.5" HDD/ SSD installation, supporting RAID 0/ 1	Humidity 10%~90% , non-condensing
M.2 1x M.2 2280 M key socket (PCIe Gen3 x4) for NVMe SSD or Intel® Optane™ memory installation	Vibration Operating, MIL-STD-810G, Method 514.6, Category 4
mSATA 1x full-size mSATA port (mux with mini-PCIe)	Shock Operating, MIL-STD-810G, Method 516.6, Procedure I, Table 516.6-II
EMC CE/FCC Class A, according to EN 55032 & EN 55024	

* For i7-8700 running at 65W mode, the highest operating temperature shall be limited to 50°C and thermal throttling may occur when sustained full-loading applied. Users can configure CPU power in BIOS to obtain higher operating temperature.
 ** For sub-zero operating temperature, a wide temperature HDD or Solid State Disk (SSD) is required.

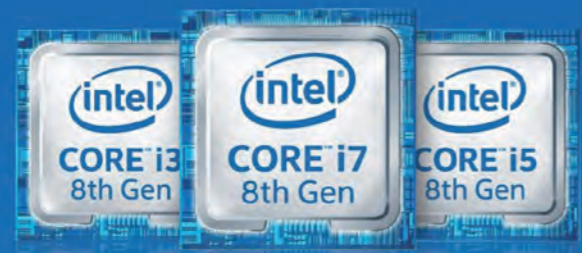

Intel® 8th-Gen Coffee Lake Core™ i Fanless Embedded Computer

Appearance

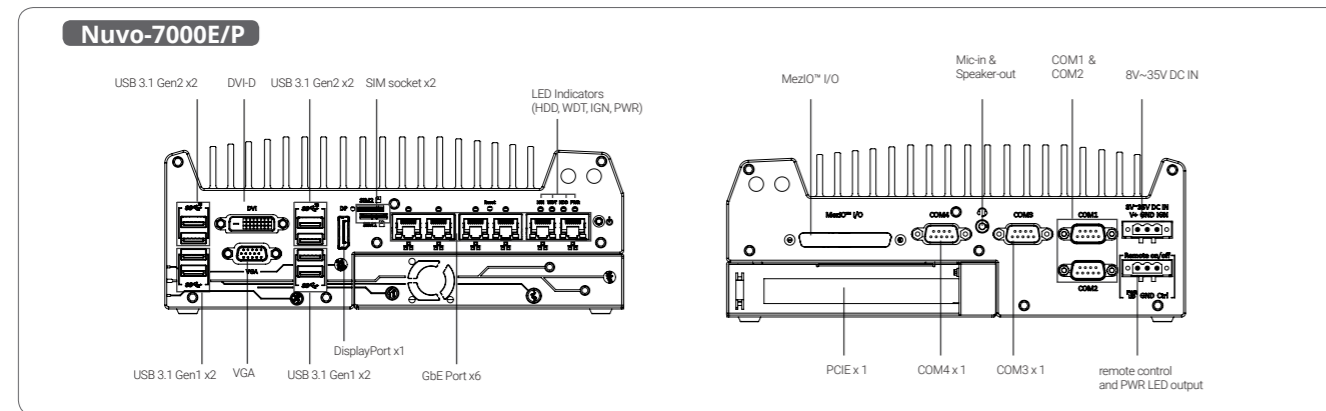

Dimensions

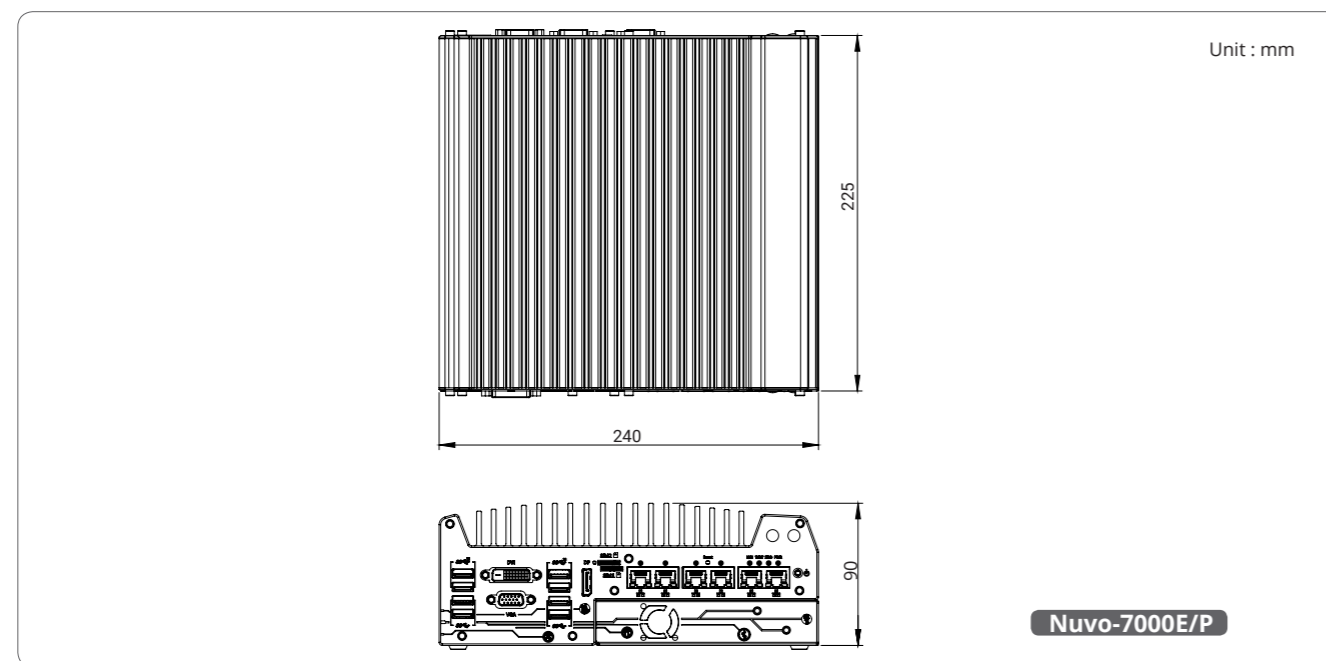

Ordering Information

Model No.	Product Description
Nuvo-7002E	Intel® 8th-Gen Core™ fanless controller with 2x GbE, single-slot PCI Express Cassette and MeziO™
Nuvo-7002P	Intel® 8th-Gen Core™ fanless controller with 2x GbE, single-slot PCI Cassette and MeziO™
Nuvo-7006E	Intel® 8th-Gen Core™ fanless controller with 6x GbE, single-slot PCI Express Cassette and MeziO™
Nuvo-7006P	Intel® 8th-Gen Core™ fanless controller with 6x GbE, single-slot PCI Cassette and MeziO™

Option of 802.3at PoE+ for GbE ports 3 ~ 6

Optional Accessories

DINRAIL-O	DIN-rail mounting assembly for Nuvo-7000 series
Damping bracket	Neosys' patented damping bracket assembly for Nuvo-7000E/DE/P
Fan-25	Fan assembly for 1-slot Cassette, 25x25x10 mm
PA-160W-OW	160W AC/DC power adapter 20V/8A; 18AWGx4C/120cm, cord end terminals for terminal block, operating temperature : -30°C to 70°C.
Cassette Modules	
CSM-PoE354	Cassette module with PCIe-PoE354 and pre-installed passive heat-spreader
CSM-USB380	Cassette module with PCIe-USB380 and pre-installed passive heat-spreader
CSM-NV750	Cassette module with NVIDIA® GTX 750 Ti graphics card, pre-installed heat-spreader and fan
CSM-R800	Cassette module accommodating four 2.5" HDD/ SSD (support RAID 0/ 1/ 10)

MeziO™ Modules	
MeziO™ -C180	MeziO™ module with 4x RS-232/ 422/ 485 ports and 4x RS-232 ports
MeziO™ -C181	MeziO™ module with 4x RS-232/ 422/ 485 ports and 4x RS-422/ 485 ports
MeziO™ -D220	MeziO™ module with 8-CH isolated digital input and 8-CH isolated digital output
MeziO™ -D230	MeziO™ module with 16-CH isolated digital input and 16-CH isolated digital output
MeziO™ -V20-EP	MeziO™ module with ignition power control function for in-vehicle application
MeziO™ -U4	MeziO™ module with 4x USB3.0 ports
MeziO™ -G4	MeziO™ module with 4x GigE ports
MeziO™ -G4P	MeziO™ module with 4x IEEE 802.3at PoE ports

Appearance

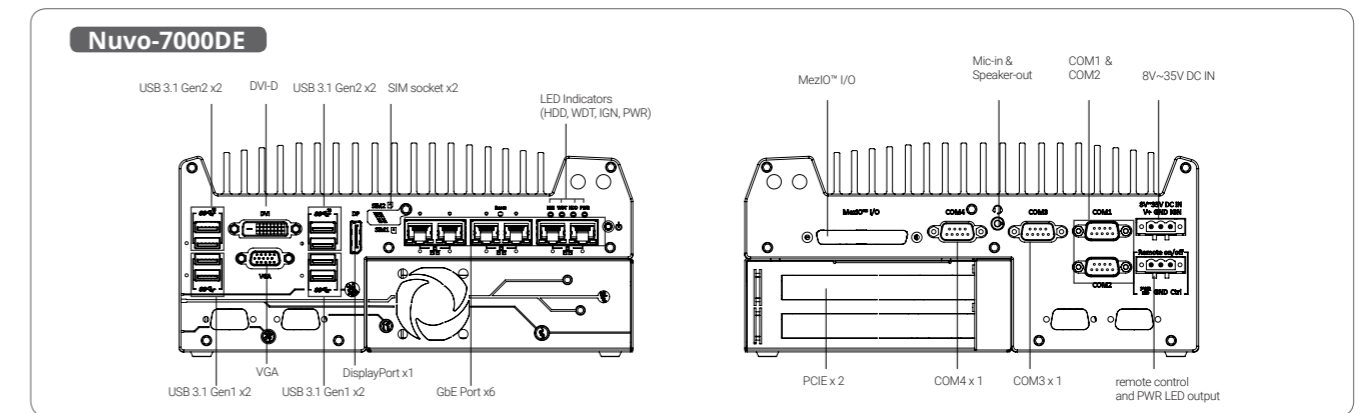

Dimensions

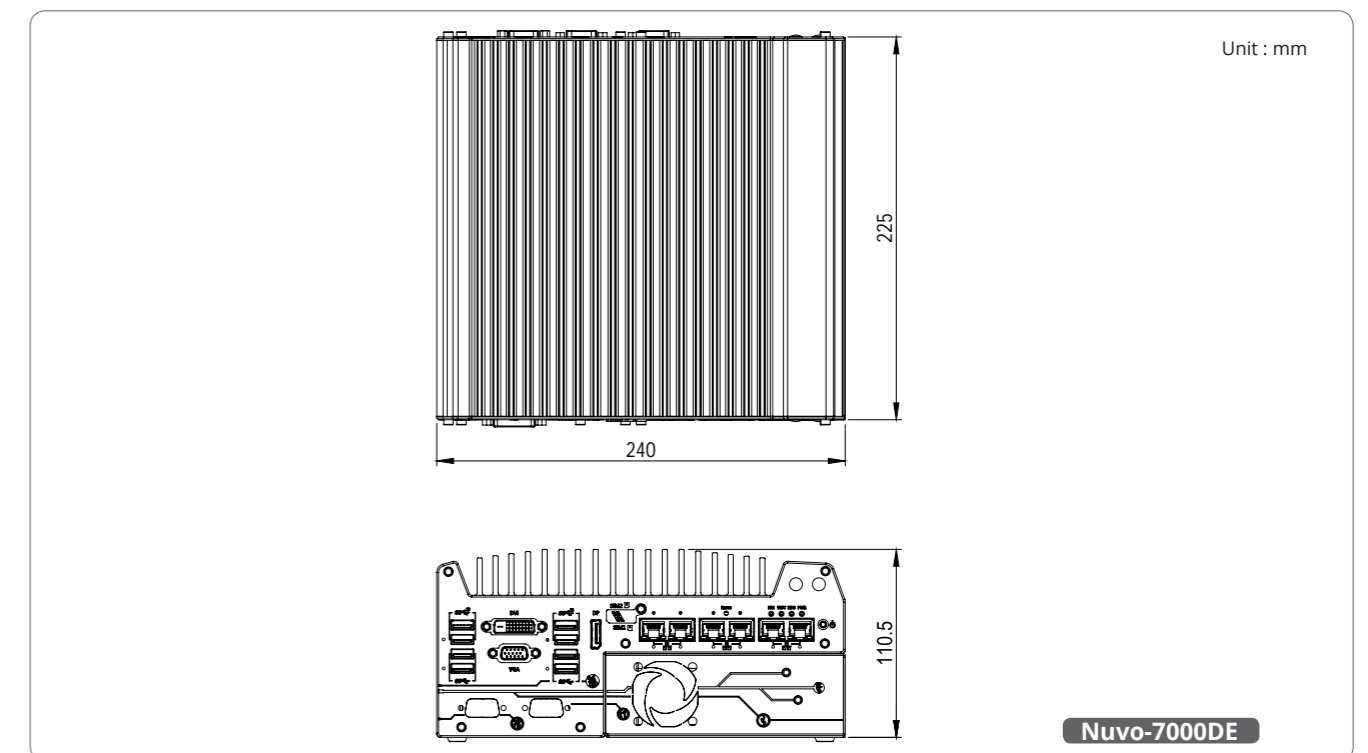

Ordering Information

Model No.	Product Description
Nuvo-7002DE	Intel® 8th-Gen Core™ fanless controller with 2x GbE, dual-slot PCI Express Cassette and MeziO™
Nuvo-7006DE	Intel® 8th-Gen Core™ fanless controller with 6x GbE, dual-slot PCI Express Cassette and MeziO™

Option of 802.3at PoE+ for GbE ports 3 ~ 6

Optional Accessories

PA-160W-OW	160W AC/DC power adapter 20V/8A; 18AWGx4C/120cm, cord end terminals for terminal block, operating temperature : -30°C to 70°C.
Fan-40	Fan assembly for 1-slot Cassette, 40x40x10 mm
Damping bracket	Neosys' patented damping bracket assembly for Nuvo-7000E/DE/P
DINRAIL-O	DIN-rail mounting assembly for Nuvo-7000 series
MeziO™ Modules	
MeziO™ -C180	MeziO™ module with 4x RS-232/ 422/ 485 ports and 4x RS-232 ports
MeziO™ -C181	MeziO™ module with 4x RS-232/ 422/ 485 ports and 4x RS-422/ 485 ports
MeziO™ -D220	MeziO™ module with 8-CH isolated digital input and 8-CH isolated digital output
MeziO™ -D230	MeziO™ module with 16-CH isolated digital input and 16-CH isolated digital output
MeziO™ -V20-EP	MeziO™ module with ignition power control function for in-vehicle application
MeziO™ -U4	MeziO™ module with 4x USB3.0 ports
MeziO™ -G4	MeziO™ module with 4x GigE ports
MeziO™ -G4P	MeziO™ module with 4x IEEE 802.3at PoE ports

Nuvo-7000LP Series

Intel® 8th-Gen Coffee Lake Core™ i7/ i5/ i3 Fanless Controller with 6x GbE Ports, MezIO™ Interface and Low-profile Chassis



Key Features

- Intel® 8th-Gen Core™ i hexa-core 35W/ 65W LGA1151 CPU
- Low-profile chassis with hot-swappable 2.5" HDD/ SSD tray
- MezIO™ interface for easy function expansion
- Rugged, -25°C to 70°C fanless operation
- Up to 6x GigE ports, supporting 9.5 KB jumbo frame
- M.2 2280 M key socket (Gen3 x4) supporting NVMe SSD or Intel® Optane™ memory
- 4x USB 3.1 Gen2 ports and 4x USB 3.1 Gen1 ports
- VGA/ DVI/ DP triple independent display, supporting 4K2K resolution



Introduction

Introducing Neosys Technology's 2018 flagship rugged fanless controllers, the new Nuvo-7000 series, powered by Intel® 8th-Gen Core™ i processors with up to 6-core/ 12-thread architecture that offer a significant performance improvement over previous 6th or 7th-Gen platforms.

Nuvo-7000LP series is a derivative of Nuvo-7000 series that features the same level of ruggedness and versatility in a 79 mm low-profile chassis. In addition to effective fanless design, proprietary MezIO™ interface and plethora of on-board I/O interfaces, Nuvo-7000LP series features one front-accessible, hot-swappable HDD/ SSD tray which can be configured as RAID 0/1 when combined with the internal SATA port. It also leverages cutting-edge M.2 NVMe SSD technology for over 2000MB/s disk read/ write speed, or install an Intel® Optane™ memory for the ultimate system acceleration.

Neosys Nuvo-7000LP series consolidates the latest Intel hexa-core CPU, high-speed I/O interfaces, super-fast disk access and flexible storage configuration to form a high-performance ruggedized embedded controller. In addition, you can also take advantage of the built-in MezIO™ interface to add on modules for application-specific I/Os.

Specifications

System Core	
Processor	Supporting Intel® 8th-Gen Coffee Lake CPU (LGA1151 socket, 35W/ 65W TDP) - Intel® Core™ i7-8700/ i7-8700T - Intel® Core™ i5-8500/ i5-8500T - Intel® Core™ i3-8100/ i3-8100T - Intel® Pentium® G5400/ G5400T - Intel® Celeron® G4900/ G4900T
Chipset	Intel® Q370 Platform Controller Hub
Graphics	Integrated Intel® UHD Graphics 630
Memory	Up to 32 GB DDR4 2666/ 2400 SDRAM (two SODIMM slots)
AMT	Supports AMT 12.0
TPM	Supports TPM 2.0
I/O Interface	
Ethernet	2x Gigabit Ethernet ports by I219 and I210 (Nuvo-7002LP) 6x Gigabit Ethernet ports by I219 and 5x I210 (Nuvo-7006LP)
PoE+	Optional IEEE 802.3at PoE+ PSE for Port 3 ~ Port 6 100 W total power budget
USB	4x USB 3.1 Gen2 (10 Gbps) ports 4x USB 3.1 Gen1 (5 Gbps) ports
Video Port (Integrated Graphics)	1x VGA connector, supporting 1920 x 1200 resolution 1x DVI-D connector, supporting 1920 x 1200 resolution 1x DisplayPort connector, supporting 4096 x 2304 resolution
Serial Port	2x software-programmable RS-232/422/485 ports (COM1/ COM2) 2x RS-232 ports (COM3/ COM4)
Audio	1x 3.5 mm jack for mic-in and speaker-out
Storage Interface	
SATA HDD	1x front-accessible, hot-swappable 2.5" HDD/ SSD tray 1x internal SATA port for 2.5" HDD/ SSD installation, supporting RAID 0/ 1
M.2	1x M.2 2280 M key socket (PCIe Gen3 x4) for NVMe SSD or Intel® Optane™ memory installation
mSATA	1x full-size mSATA port (mux with mini-PCIe)
Expansion Bus	
Mini PCI Express	1x full-size mini PCI Express socket with internal SIM socket (mux with mSATA)
M.2	1x M.2 2242 B key socket with dual front-accessible SIM sockets
Expandable I/O	1x MezIO™ expansion port for Neosys MezIO™ modules
Power Supply	
DC Input	1x 3-pin pluggable terminal block for 8-35VDC DC input
Remote Ctrl. & LED Output	1x 3-pin pluggable terminal block for remote control and PWR LED output
Mechanical	
Dimension	240 mm (W) x 225 mm (D) x 79 mm (H)
Weight	3.1 kg
Mounting	Wall-mounting (standard) or DIN-Rail mounting (optional)
Environmental	
Operating Temperature	with 35W CPU -25°C ~ 70°C ** with 65W CPU -25°C ~ 70°C */** (configured as 35W TDP) -25°C ~ 50°C */** (configured as 65W TDP)
Storage Temperature	-40°C ~ 85°C
Humidity	10%~90% , non-condensing
Vibration	Operating, MIL-STD-810G, Method 514.6, Category 4
Shock	Operating, MIL-STD-810G, Method 516.6, Procedure I, Table 516.6-II
EMC	CE/FCC Class A, according to EN 55032 & EN 55024

* For i7-8700 running at 65W mode, the highest operating temperature shall be limited to 50°C and thermal throttling may occur when sustained full-loading applied. Users can configure CPU power in BIOS to obtain higher operating temperature.

** For sub-zero operating temperature, a wide temperature HDD or Solid State Disk (SSD) is required.

Appearance

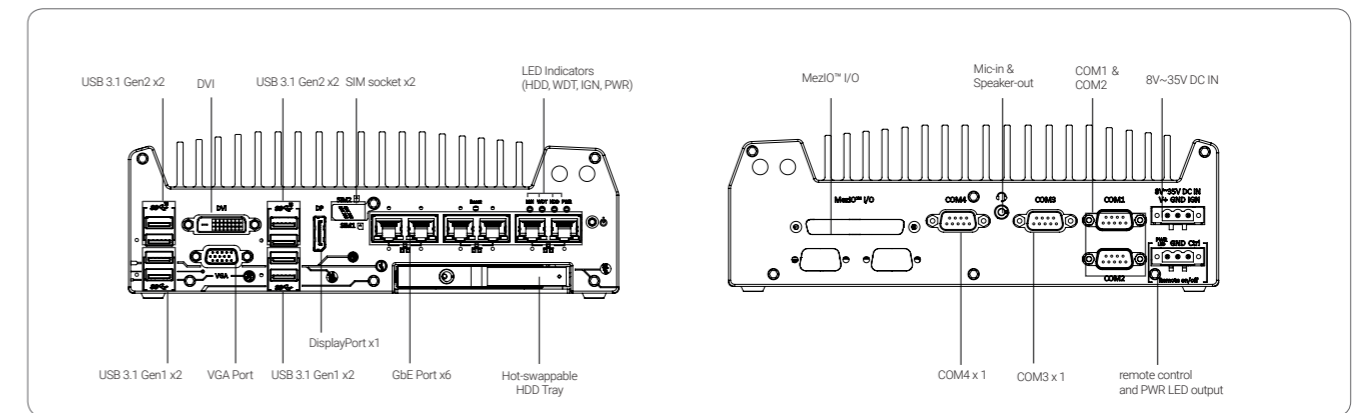

Dimensions

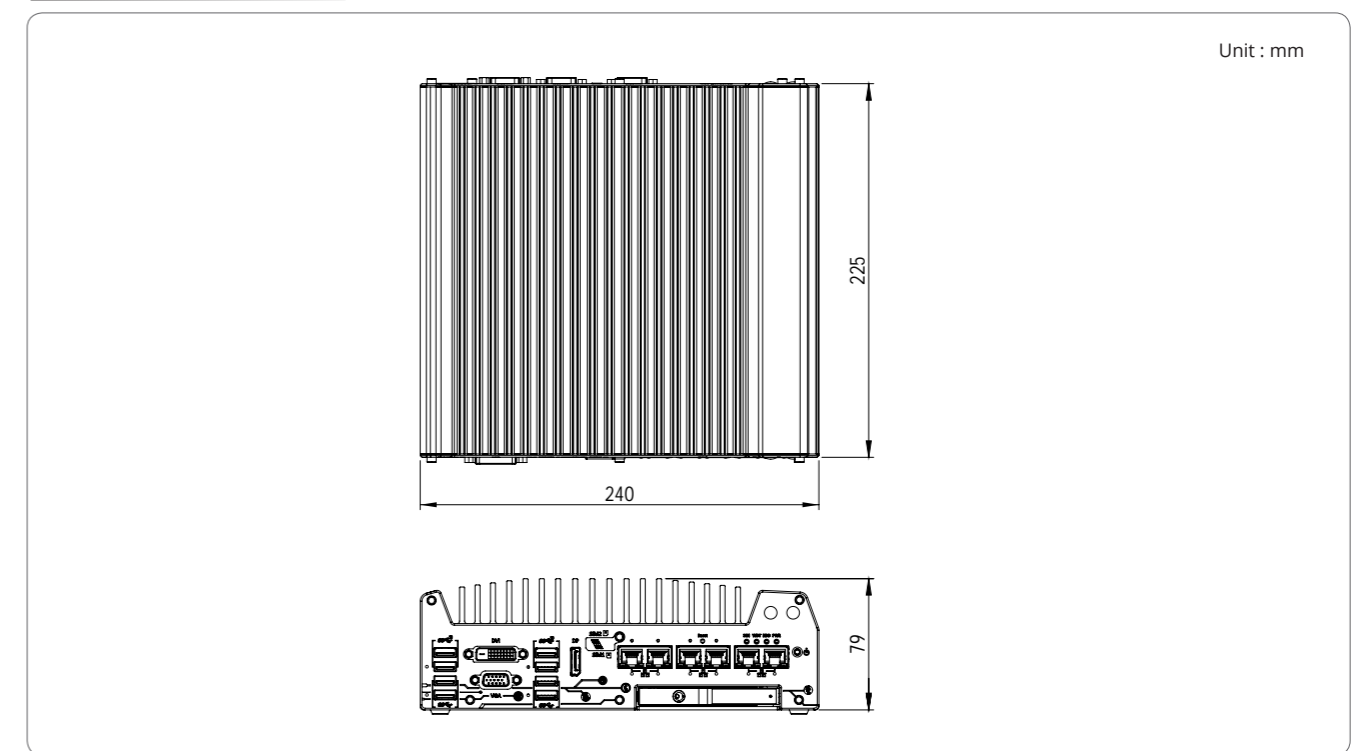

Ordering Information

Model No.	Product Description
Nuvo-7002LP	Intel® 8th-Gen Coffee Lake Core™ i7/i5/i3 fanless controller with 2x GbE ports, MezIO™ interface and low-profile chassis
Nuvo-7006LP	Intel® 8th-Gen Coffee Lake Core™ i7/i5/i3 fanless controller with 6x GbE ports, MezIO™ interface and low-profile chassis
Option of 802.3at PoE+ for GbE ports 3 ~ 6	

Optional Accessories

PA-160W-OW	160W AC/DC power adapter 20V/8A;18AWGx4C/120cm, cord end terminals for terminal block, operating temperature : -30°C to 70°C.
DINRAIL-O	DIN-rail mounting assembly for Nuvo-7000 series
MezIO™ Modules	
MezIO™-C180	MezIO™ module with 4x RS-232/ 422/ 485 ports and 4x RS-232 ports
MezIO™-C181	MezIO™ module with 4x RS-232/ 422/ 485 ports and 4x RS-422/ 485 ports
MezIO™-D220	MezIO™ module with 8-CH isolated digital input and 8-CH isolated digital output
MezIO™-D230	MezIO™ module with 16-CH isolated digital input and 16-CH isolated digital output
MezIO™-V20-EP	MezIO™ module with ignition power control function for in-vehicle application
MezIO™-U4	MezIO™ module with 4x USB3.0 ports
MezIO™-G4	MezIO™ module with 4x GigE ports
MezIO™-G4P	MezIO™ module with 4x IEEE 802.3at PoE ports

Nuvo-5026E Series

Intel® 6th-Gen Core™ i7/ i5/ i3 Fanless Controller with Dual PCIe Slot Expansion Cassette, 6x GbE and MeziO™ Interface



CE FC

Key Features

- Intel® 6th-Gen Core™ i7/ i5/ i3 LGA1151 35W/ 65W
- Dual PCIe x8 slots in patented expansion Cassette*
- MeziO™ interface for easy function expansion
- Rugged, -25°C to 70°C fanless operation
- 6x GbE ports, supporting 9.5 KB jumbo frame
- Up to 32 GB, DDR4-2133 SO-DIMM
- Accommodates two 2.5" SATA HDD/ SSD with RAID 0/1 support
- VGA/ DVI/ DP triple independent display, supporting 4K2K resolution

Introduction

Nuvo-5026E is the latest Nuvo-5000 family member with dual PCIe slots. The dual PCIe slots enhance expansion abilities while preserving all practical features such as ruggedness, performance and versatility. The expandability makes Nuvo-5026E more adaptable to various application needs while the two PCIe slots in the patented expansion Cassette are easy to access for PCIe card installation without the need to disassemble the system. Nuvo-5026E supports LGA1151 6th-Gen Core™ processors. It offers processor selection flexibility from Core™ i7 to Celeron according to performance needs and operating environment. It also offers plenty of I/O functions such as 6x GbE, 4x USB3.0, 3x COM ports and triple independent display. In addition, Neousys' MeziO™ interface can also further expand system I/Os offering up to either 11x COM ports, 10x GbE, 8x USB3.0, 32x DIO or ignition power control by installing an optional MeziO™ module. Nuvo-5026E is an expandable and flexible platform with numerous I/O functions for various industrial applications.

Specifications

System Core	Expansion Bus
Processor Intel® Core™ i7-6700 (8M Cache, 3.4/ 4.0 GHz, 65W TDP)* Intel® Core™ i5-6500 (6M Cache, 3.2/ 3.6 GHz, 65W TDP)* Intel® Core™ i3-6100 (3M Cache, 3.7 GHz, 51W TDP)* Intel® Pentium® G4400 (3M Cache, 3.3 GHz, 54W TDP)* Intel® Celeron® G3900 (2M Cache, 2.8 GHz, 51W TDP)* Intel® Core™ i7-6700TE (8M Cache, 2.4/ 3.4 GHz, 35W TDP) Intel® Core™ i5-6500TE (6M Cache, 2.3/ 3.3 GHz, 35W TDP) Intel® Core™ i3-6100TE (4M Cache, 2.7 GHz, 35W TDP) Intel® Pentium® G4400TE (3M Cache, 2.4 GHz, 35W TDP) Intel® Celeron® G3900TE (2M Cache, 2.3 GHz, 35W TDP)	PCI/PCI Express 2x PCIe x8 slot @ Gen3, 4-lanes PCIe signals in expansion Cassette Mini PCI-E 1x internal mini PCI Express socket with front-accessible SIM socket 1x internal mini PCI Express socket with internal SIM socket (mux with mSATA) Expandable I/O 1x MeziO™ expansion port for Neousys' MeziO™ modules
Chipset Intel® Q170 platform controller hub	Power Supply DC Input 1x 3-pin pluggable terminal block for 8~35VDC DC input Remote Ctrl. & Status Output 1x 10-pin (2x5) wafer connector for remote on/off control and status LED output
Graphics Integrated Intel® HD graphics 530 or 510 (CPU dependent)	Mechanical Dimension 240 mm (W) x 225 mm (D) x 111 mm (H) Weight 3.7 kg (incl. CPU, memory and HDD) Mounting Wall-mount by mounting bracket (standard) or DIN-rail mounting (optional)
Memory Up to 32 GB DDR4-2133 SDRAM (two SO-DIMM slots)	Environmental Operating Temperature -25°C ~ 70°C ** i7-6700TE (35W TDP) i5-6500TE (35W TDP) i3-6100TE (35W TDP) Pentium G4400TE (35W TDP) -25°C ~ 70°C */*** (configured as 35W CPU mode) i7-6700 (65W/51W TDP) -25°C ~ 50°C */*** (configured as 65W/ 51W CPU mode) i5-6500 (65W/51W TDP) i3-6100 (65W/51W TDP)
AMT Supports AMT 11.0	Storage Temperature -40°C ~ 85°C
TPM Supports TPM 2.0	Humidity 10%~90% , non-condensing
I/O Interface	Vibration Operating, 5 Grms, 5-500 Hz, 3 Axes (w/ SSD, according to IEC60068-2-64)
Ethernet 6x Gigabit Ethernet ports by Intel® I219 and 5x I210	Shock Operating, 50 Grms, Half-sine 11 ms Duration (w/ SSD, according to IEC60068-2-27)
PoE+ Optional IEEE 802.3at PoE+ PSE for GbE Port 3 ~ Port 6, 80 W total power budget	EMC CE/ FCC Class A, according to EN55024 & EN55032
USB 4x USB3.0 ports via native xHCI controller 4x USB 2.0 ports	
Video Port 1x stacked VGA + DVI-D connector 2x DisplayPort connectors, supporting 4K2K resolution	
Serial Port 2x software-programmable RS-232/ 422/ 485 port (COM1 & COM3) 1x RS-232 port (COM2)	
Audio 1x Mic-in and 1x Speaker-out	
Storage Interface	
SATA HDD 2x internal SATA port for 2.5" HDD/ SSD installation, supporting RAID 0/1	
mSATA 1x full-size mSATA port (mux with mini-PCIe)	

* For i7-6700 running at 65W mode, the highest operating temperature shall be limited to 50°C and thermal throttling may occur when sustained full-loading applied. Users can configure CPU power in BIOS to obtain higher operating temperature.
** For sub-zero operating temperature, a wide temperature HDD drive or Solid State Disk (SSD) is required.

Appearance

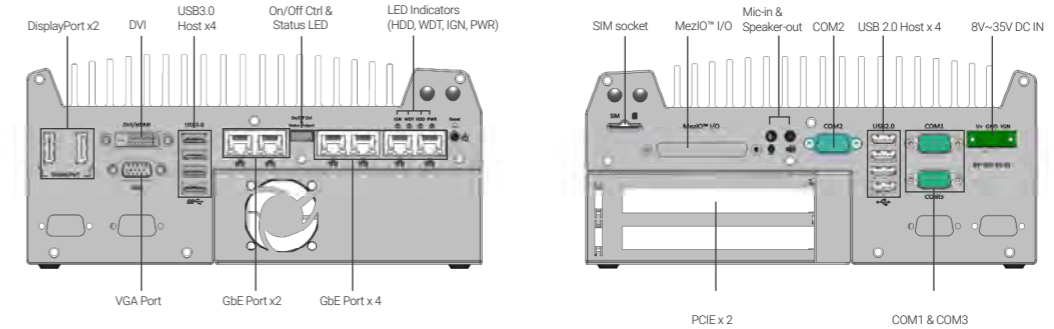

Dimensions

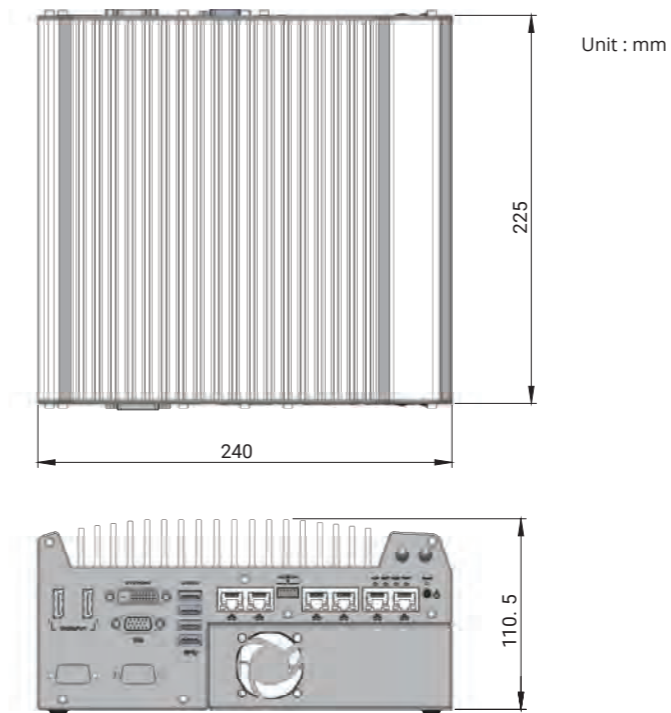

▲ Nuvo-5026E



▲ Dual PCIe Cassette

Ordering Information

Model No.	Product Description
Nuvo-5026E	Intel® 6th-Gen Core™ fanless controller with dual PCIe Cassette, 6x GbE and MeziO™
	Optional 802.3at PoE+ for GbE port 3 ~ port 6

Optional Accessories

PA-160W-OW	160W AC/DC power adapter 20V/8A; 18AWGx4C/120cm, cord end terminals for terminal block. operating temperature : -30 to 70 °C.
DINRAIL-O	DIN-rail mounting assembly for Nuvo-5026E series

MeziO™ Modules

MeziO™-C180	MeziO™ module with 4x RS-232/422/485 ports and 4x RS-232 ports
MeziO™-C181	MeziO™ module with 4x RS-232/422/485 ports and 4x RS-422/485 ports
MeziO™-D220	MeziO™ module with 8-CH isolated digital input and 8-CH isolated digital output
MeziO™-D230	MeziO™ module with 16-CH isolated digital input and 16-CH isolated digital output
MeziO™-V20-EP	MeziO™ module with ignition power control function for in-vehicle usage
MeziO™-G4P	MeziO™ module with 4x Gigabit 802.3at PoE+ ports
MeziO™-G4	MeziO™ module with 4x Gigabit Ethernet ports
MeziO™-U4	MeziO™ module with 4x USB3.0

Nuvo-5501 Series

Intel® 6th-Gen Core™ i7/ i5/ i3 Compact Fanless Embedded Controller with 3x GbE



Key Features

- Compact 221 x 173 x 76.2 mm footprint
- Supports Intel® 6th-Gen Core™ i7/ i5/ i3 LGA 1151 socket CPU
- Rugged, -25°C to 70°C wide-temperature fanless operation
- 3x GbE and 4x USB3.0 ports
- 2x RS-232/ 422/ 485 ports and 2x RS-232 ports
- VGA + DVI dual display outputs
- Accommodates one 3.5" HDD or 2.5" HDD/ SSD
- Optional 8-CH isolated DI and 8-CH isolated DO

Introduction

Nuvo-5501 series features compact fanless embedded controllers for the cost and space conscious. Based on Intel® Skylake platform, it is designed to provide cutting-edge performance and reliable operation in extreme environment. Its LGA 1151 socket offers users the flexibility to select a 35W CPU from Intel® 6th-Gen Core™ i to Celeron® lineup to suit application needs.

Nuvo-5501 is the most compact fanless embedded controller supporting Skylake LGA 1151 socket CPUs, measuring just 221 x 173 x 76.2 mm, it is easy to deploy in restricted spaces. In its compact enclosure, Nuvo-5501 features rich, front-accessible I/Os including 3x GbE, 4x USB3.0 and 4x COM ports. There is even enough room for a 3.5" HDD, compatible with the latest storage capacities.

The compact Nuvo-5501 is a cost-effective solution that does not compromise on performance and reliability, making it the ideal embedded controller for various industrial applications.

Specifications

System Core		Expansion Bus/ Internal I/O Interface	
Processor	Supports following CPUs	mini-PCIe	1x full-size mini PCI Express socket
	- Intel® Core™ i7-6700TE (8M Cache, 2.4/ 3.4 GHz, 35W TDP)	M.2	1x M.2 B key socket for 3G/ 4G options with SIM socket
	- Intel® Core™ i5-6500TE (6M Cache, 2.3/ 3.3 GHz, 35W TDP)	USB	1x internal USB2.0 port
	- Intel® Core™ i3-6100TE (4M Cache, 2.7 GHz, 35W TDP)	Remote Ctrl. & Status Output	1x 2x6-pin 2.0mm pin-header connector for remote on/off control and status LED output
	- Intel® Pentium® G4400TE (3M Cache, 2.4 GHz, 35W TDP)	Power Supply	
- Intel® Celeron® G3900TE (2M Cache, 2.3 GHz, 35W TDP)	DC Input	1x 3-pin pluggable terminal block for 8-35 VDC power input	
Chipset	Intel® H110 platform controller hub	Mechanical	
Graphics	Integrated Intel® HD 530/ 510 controller	Dimension	221 mm (W) x 173 mm (D) x 76.2 mm (H)
Memory	Up to 16GB DDR4-2133 (single SO-DIMM slot)	Weight	2.8 Kg (incl. CPU, memory and HDD)
I/O Interface		Mounting	Wall-mount (standard) or DIN-rail mount (optional)
Ethernet port	1x Gigabit Ethernet port (via Intel® I219-LM) 2x Gigabit Ethernet port (via Intel® I210-IT)	Environmental	
USB	4x USB3.0 ports 2x USB2.0 ports	Operating Temperature	-25°C ~ 70°C */**
Video port	1x VGA connector 1x DVI-D connector	Storage Temperature	-40°C ~ 85°C
Serial Port	2x software-programmable RS-232/ 422/ 485 ports 2x RS-232 ports	Humidity	10%~90% , non-condensing
Isolated DIO	8-CH isolated DI and 8-CH isolated DO (optional)	Vibration	Operating, 5 Grms, 5-500 Hz, 3 Axes (w/ SSD, according to IEC60068-2-64)
Storage Interface		Shock	Operating, 50 Grms, half-sine 11 ms duration (w/ SSD, according to IEC60068-2-27)
SATA HDD	1x internal SATA port for 3.5" HDD or 2.5" HDD/ SSD	EMC	CE/ FCC Class A, according to EN 55022, EN 55024 & EN 55032
mSATA	1x full-size mSATA socket		

* The 100% CPU loading is applied using Passmark® BurnInTest 8.1. For detail testing criteria, please contact Neosys Technology
** For sub-zero operating temperature, a wide temperature HDD drive or Solid State Disk (SSD) is required.

Appearance

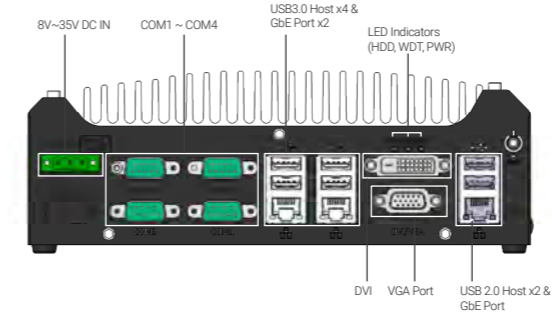

Dimensions

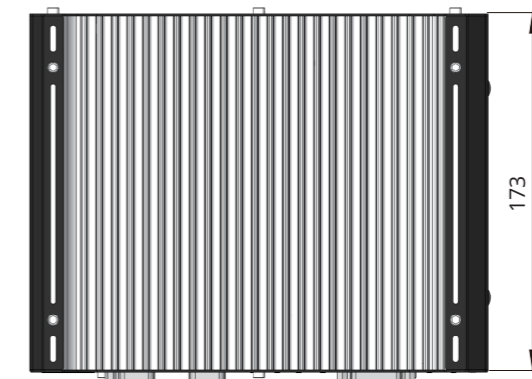

Unit: mm

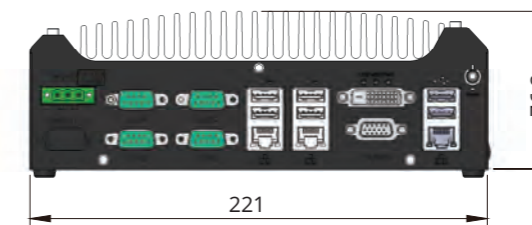

Ordering Information

Model No.	Product Description
Nuvo-5501	Intel® 6th-Gen Core™ i7/ i5/ i3 compact fanless embedded controller with 3x GbE
Nuvo-5501-DIO	Intel® 6th-Gen Core™ i7/ i5/ i3 compact fanless embedded controller with isolated DIO & 3x GbE

Optional Accessories

DINRAIL-31	DIN-rail mounting assembly for Nuvo-5501 series
PA-120W-OW	120W AC/DC power adapter 20V/6A; 18AWG/120cm; cord end terminals for terminal block, operating temperature: -30 to 70 °C.

Nuvo-5000E/P Series

Intel® 6th-Gen Core™ i7/ i5/ i3 Fanless Controller with 6x GbE, Expansion Cassette and MeziO™ Interface



Key Features

- Intel® 6th-Gen Core™ i7/ i5/ i3 35W/65W LGA1151 CPU
- Patented Cassette* for PCI/ PCIe add-on card
- MeziO™ interface for easy function expansion
- Rugged, -25°C to 70°C fanless operation
- Up to 6x GigE ports, supporting 9.5 KB jumbo frame
- Up to 32 GB, DDR4-2133 SO-DIMM
- Accommodates two 2.5" SATA HDD/ SSD with RAID 0/ 1 support
- VGA/ DVI/ DP triple independent display, supporting 4K2K resolution

*R.O.C Patent No. M456527

Introduction

Integrating cutting-edge technologies, Nuvo-5000 is Neosys' next-generation rugged fanless embedded controller with performance and versatility. It supports socket-type 6th-Gen Core™ processors so one can choose a CPU according to application performance needs while Neosys' efficient heat-dissipating design offers true -25°C to 70°C wide-temperature operation.

With plenty of embedded I/O connections for applications including Gigabit Ethernet, USB3.0/ USB2.0, COM ports, VGA/ DVI/ DP triple display outputs and if that's not enough, Neosys' patented Cassette offers I/O expansion by installing an off-the-shelf PCIe/PCI card.

On top of all that, Nuvo-5000 also incorporates Neosys MeziO™ interface. The patented design enhances Neosys' embedded system with a cost-effective and reliable way for I/O expansion. The MeziO™ module can deliver application-oriented functions for diversified vertical markets.

Neosys Nuvo-5000 features 6th-Gen Intel® CPU, patented Cassette and MeziO™ to create a powerful and yet diverse controller for all your industrial application needs!

Specifications

System Core	Expansion Bus
Processor	PCI/PCI Express
Intel® Core™ i7-6700 (8M Cache, 3.4/ 4.0 GHz, 65W TDP)* Intel® Core™ i5-6500 (6M Cache, 3.2/ 3.6 GHz, 65W TDP)* Intel® Core™ i3-6100 (3M Cache, 3.7 GHz, 51W TDP)* Intel® Pentium® G4400 (3M Cache, 3.3 GHz, 54W TDP)* Intel® Celeron® G3900 (2M Cache, 2.8 GHz, 51W TDP)* Intel® Core™ i7-6700TE (8M Cache, 2.4/ 3.4 GHz, 35W TDP) Intel® Core™ i5-6500TE (6M Cache, 2.3/ 3.3 GHz, 35W TDP) Intel® Core™ i3-6100TE (4M Cache, 2.7 GHz, 35W TDP) Intel® Pentium® G4400TE (3M Cache, 2.4 GHz, 35W TDP) Intel® Celeron® G3900TE (2M Cache, 2.3 GHz, 35W TDP)	1x PCI slot in Cassette (Nuvo-5002P/5006P) 1x PCIe x16 slot @ Gen3, 8-lanes PCIe signals in Cassette (Nuvo-5002E/ 5006E)
Chipset	Mini PCI-E
Intel® Q170 platform controller hub	1x internal Mini PCIe socket with front-accessible SIM socket 1x internal Mini PCIe socket with internal SIM socket (mux with mSATA)
Graphics	Expandable I/O
Integrated Intel® HD graphics 530/ 510	1x MeziO™ expansion port for Neosys' MeziO™ modules
Memory	Power Supply
Up to 32GB DDR4-2133 SDRAM (two SO-DIMM slots)	DC Input
AMT	1x 3-pin pluggable terminal block for 8-35VDC DC input
Supports AMT 11.0	Remote Ctrl. & Status Output
TPM	1x 10-pin (2x5) wafer connector for remote on/off control and status LED output
Supports TPM 2.0	Mechanical
I/O Interface	Dimension
Ethernet	240mm (W) x 225mm (D) x 90mm (H)
2x Gigabit Ethernet ports by Intel® 1x I219 and I210 (Nuvo-5002E/P) 6x Gigabit Ethernet ports by Intel® 1x I219 and 5x I210 (Nuvo-5006E/ P)	Weight
PoE+	3.6kg (incl. CPU, memory and HDD)
Optional IEEE 802.3at PoE+ PSE for GbE Ports 3 ~ 6, 80W total power budget	Mounting
USB	Wall-mounting (standard) or DIN-rail mounting (optional)
4x USB3.0 ports via native xHCI controller 4x USB2.0 ports	Environmental
Video Port	Operating Temperature
1x stacked VGA + DVI-D connector 2x DisplayPort connectors, supporting 4K2K resolution (triple-independent display support)	-25°C ~ 70°C ** i7-6700TE (35W TDP) i5-6500TE (35W TDP) i3-6100TE (35W TDP) Pentium G4400TE (35W TDP)
Serial Port	-25°C ~ 70°C */** (configured as 35W CPU mode) i7-6700 (65W/51W TDP) i5-6500 (65W/51W TDP) -25°C ~ 50°C */** (configured as 65W/ 51W CPU mode) i3-6100 (65W/51W TDP)
2x software-programmable RS-232/ 422/ 485 port (COM1 & COM3) 1x RS-232 port (COM2)	Storage Temperature
Audio	-40°C ~ 85°C
1x Mic-in and 1x speaker-out	Humidity
Storage Interface	10%~90% , non-condensing
SATA HDD	Vibration
2x internal SATA port for 2.5" HDD/ SSD installation, supporting RAID 0/1	Operating, 5Grms, 5-500 Hz, 3 Axes (w/ SSD, according to IEC60068-2-64)
mSATA	Shock
1x full-size mSATA port (mux with mini-PCIe)	Operating, 50Grms, Half-sine 11ms Duration (w/ SSD, according to IEC60068-2-27)
	EMC
	CE/FCC Class A, according to EN 55022, EN 55024, EN 55032 & EN 60950

* For i7-6700 running at 65W mode, the high operating temperature shall be limited to 50°C and thermal throttling may occur when sustained full-loading applied. Users can configure CPU power in BIOS to obtain higher operating temperature.
** For sub-zero operating temperature, a wide temperature HDD drive or Solid State Disk (SSD) is required.

Appearance

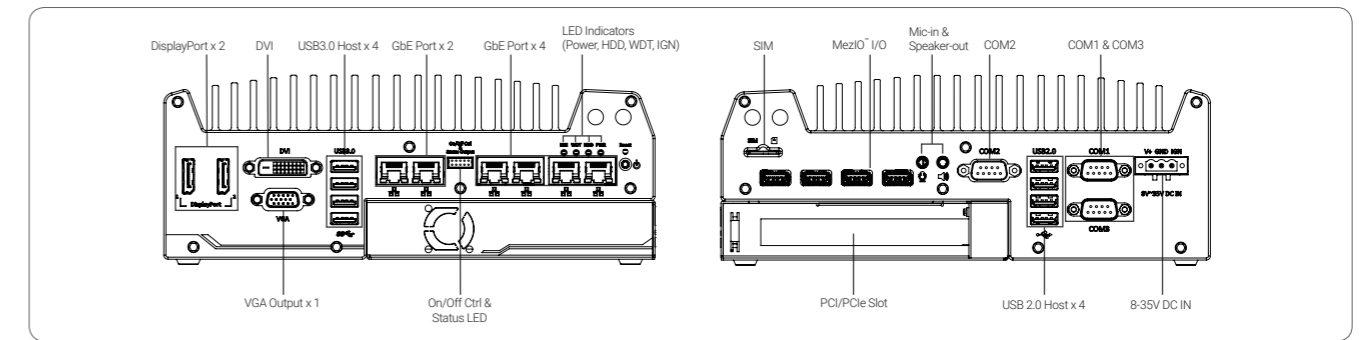

Dimensions

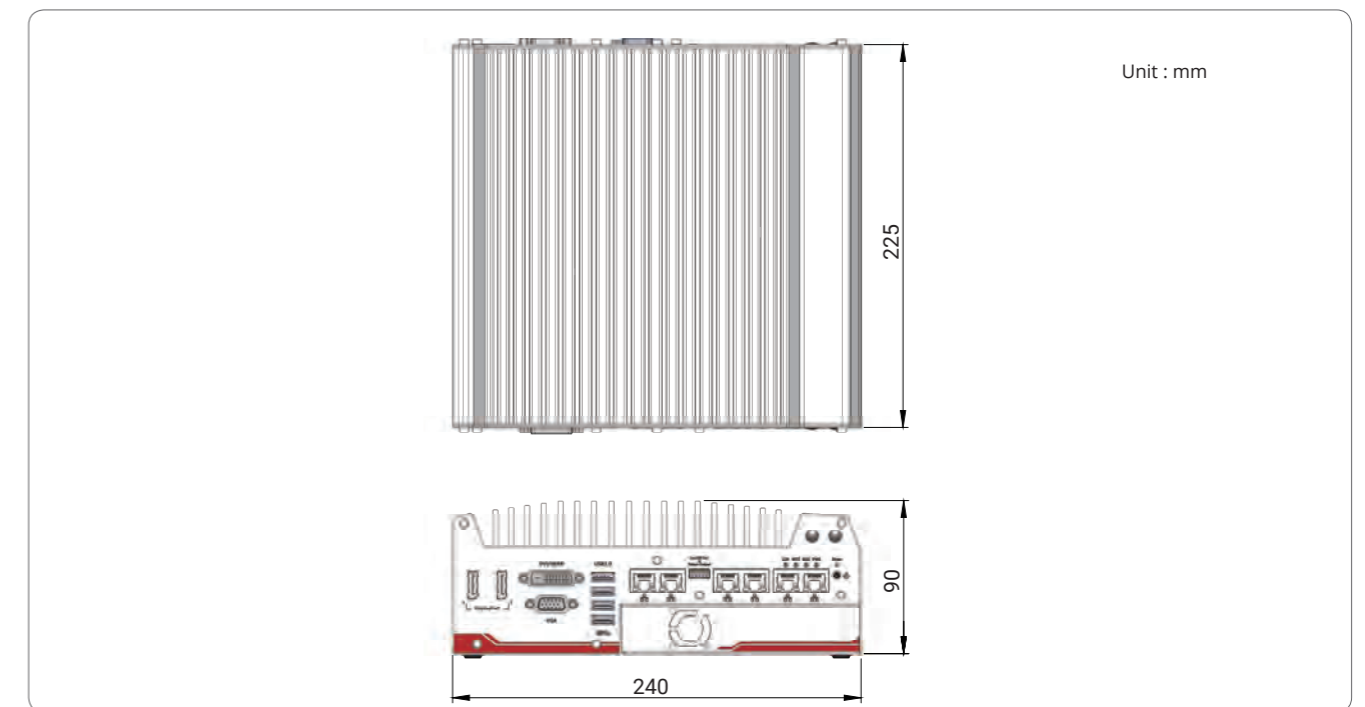

Ordering Information

Model No.	Product Description
Nuvo-5002E	Intel® 6th-Gen Core™ i fanless controller with 2x GbE, PCI Express Cassette and MeziO™
Nuvo-5002P	Intel® 6th-Gen Core™ i fanless controller with 2x GbE, PCI Cassette and MeziO™
Nuvo-5006E	Intel® 6th-Gen Core™ i fanless controller with 6x GbE, PCI Express Cassette and MeziO™
Nuvo-5006P	Intel® 6th-Gen Core™ i fanless controller with 6x GbE, PCI Cassette and MeziO™

Optional upgrade for GbE ports 3~6 to IEEE802.3at PoE+ ports

Optional Accessories

DINRAIL-0	DIN-rail mounting assembly for Nuvo-5000 series
Fan-25	Fan assembly for 1-slot Cassette, 25x25x10 mm
PA-120W-OW	120W AC/DC power adapter 20V/6A; 18AWG/120cm; cord end terminals for terminal block, operating temperature: -30 to 70 °C.
Cassette Modules	
CSM-PoE354	Cassette module with PCIe-PoE354 and pre-installed passive heat-spreader
CSM-USB380	Cassette module with PCIe-USB380 and pre-installed passive heat-spreader
CSM-NV750	Cassette module with NVIDIA® GTX 750 Ti graphics card, pre-installed heat-spreader and fan
CSM-R800	Cassette module accommodating four 2.5" HDD/ SSD (support RAID 0/ 1/ 10)

MeziO™ Modules	
MeziO™-C180	MeziO™ module with 4x RS-232/ 422/ 485 ports and 4x RS-232 ports
MeziO™-C181	MeziO™ module with 4x RS-232/ 422/ 485 ports and 4x RS-422/ 485 ports
MeziO™-D220	MeziO™ module with 8-CH isolated digital input and 8-CH isolated digital output
MeziO™-D230	MeziO™ module with 16-CH isolated digital input and 16-CH isolated digital output
MeziO™-V20-EP	MeziO™ module with ignition power control function for in-vehicle application
MeziO™-U4	MeziO™ module with 4x USB3.0 ports
MeziO™-G4	MeziO™ module with 4x GigE ports
MeziO™-G4P	MeziO™ module with 4x IEEE 802.3at PoE ports

Nuvo-5000LP Series

Intel® 6th-Gen Core™ i7/i5/i3 Fanless Controller with 6x GbE, MezIO™ Interface and Low-profile Chassis



Key Features

- Intel® 6th-Gen Core™ i7/ i5/ i3 35W/ 65W LGA1151 CPU
- MezIO™ interface for easy function expansion
- Rugged, -25°C to 70°C fanless operation
- Up to 6x GigE ports, supporting 9.5 KB jumbo frame
- Up to 32GB, DDR4-2133 SO-DIMM
- One hot-swappable 2.5" HDD/ SSD and one fixed 2.5" HDD/ SSD, supporting RAID 0/ 1
- VGA/ DVI/ DP triple independent display, supporting 4K2K resolution
- 77mm low-profile design



Introduction

Nuvo-5002LP/ 5006LP are low-profile systems in the Nuvo-5000 family. They feature a 77mm low-profile chassis and yet retain extraordinary -25°C to 70°C wide operating temperature capability. Neosys Nuvo-5002LP/ 5006LP supports LGA1151 socket-type CPUs so one can choose an Intel® 6th-Gen Core™ i7/i5/i3, from 35W to 65W TDP CPU according to application performance and operation needs. Nuvo-5002LP/ 5006LP has plentiful I/Os such as GbE, USB3.0/ USB2.0, COM and VGA/ DVI/ DP. It also incorporates Neosys' MezIO™ interface for additional or application-oriented I/O expansion. By installing an optional MezIO™ module, Nuvo-5002LP/ 5006LP transforms from a typical embedded controller to a ruggedized application platform that may include up to 11x COM ports, 32 DIO channels, ignition power control or customized application-specific I/Os.

Specifications

System Core	
Processor	Intel® Core™ i7-6700 (8M Cache, 3.4/ 4.0 GHz, 65W TDP)* Intel® Core™ i5-6500 (6M Cache, 3.2/ 3.6 GHz, 65W TDP)* Intel® Core™ i3-6100 (3M Cache, 3.7 GHz, 51W TDP)* Intel® Pentium® G4400 (3M Cache, 3.3 GHz, 54W TDP)* Intel® Celeron® G3900 (2M Cache, 2.8 GHz, 51W TDP)* Intel® Core™ i7-6700TE (8M Cache, 2.4/ 3.4 GHz, 35W TDP) Intel® Core™ i5-6500TE (6M Cache, 2.3/ 3.3 GHz, 35W TDP) Intel® Core™ i3-6100TE (4M Cache, 2.7 GHz, 35W TDP) Intel® Pentium® G4400TE (3M Cache, 2.4 GHz, 35W TDP) Intel® Celeron® G3900TE (2M Cache, 2.3 GHz, 35W TDP)
Chipset	Intel® Q170 Platform Controller Hub
Graphics	Integrated Intel® HD Graphics 530/ 510
Memory	Up to 32GB DDR4-2133 SDRAM (two SO-DIMM slots)
AMT	Supports AMT 11.0
TPM	Supports TPM 2.0
I/O Interface	
Ethernet	2x Gigabit Ethernet ports by Intel® I219 and I210 (Nuvo-5002LP) 6x Gigabit Ethernet ports by Intel® I219 and 5x I210 (Nuvo-5006LP)
PoE+	Optional IEEE 802.3at PoE+ PSE for GbE Ports 3 ~ 6, 80W total power budget
USB	4x USB3.0 ports via native xHCI controller 4x USB2.0 ports
Video Port	1x stacked VGA + DVI-D connector 2x DisplayPort connectors, supporting 4K2K resolution (triple-independent display support)
Serial Port	2x software-programmable RS-232/ 422/ 485 port (COM1 & COM3) 1x RS-232 port (COM2)
Audio	1x Mic-in and 1x speaker-out
Storage Interface	
SATA HDD	1x hot-swappable HDD tray for 2.5" HDD/ SSD installation 1x internal SATA port for 2.5" HDD/ SSD installation, supporting RAID 0/ 1
mSATA	1x full-size mSATA port (mux with mini-PCIe)
Expansion Bus	
Mini PCI-E	1x internal mini PCI Express socket with front-accessible SIM socket 1x internal mini PCI Express socket with internal SIM socket (mux. with mSATA)
Expandable I/O	1x MezIO™ expansion interface for Neosys MezIO™ modules
Power Supply	
DC Input	1x 3-pin pluggable terminal block for 8~35VDC DC input
Remote Ctrl. & Status Output	1x 10-pin (2x5) wafer connector for remote on/ off control and status LED output
Mechanical	
Dimension	240mm (W) x 225mm (D) x 77mm (H)
Weight	3.1kg (incl. CPU, memory and HDD)
Mounting	Wall-mounting (standard) or DIN-rail mounting (optional)
Environmental	
Operating Temperature	-25°C ~ 70°C ** -25°C ~ 70°C */** (configured as 35W CPU mode) -25°C ~ 50°C */** (configured as 65W/ 51W CPU mode)
Storage Temperature	-40°C ~ 85°C
Humidity	10%~90%, non-condensing
Vibration	Operating, 5 Grms, 5-500 Hz, 3 Axes (w/ SSD, according to IEC60068-2-64)
Shock	Operating, 50 Grms, Half-sine 11 ms Duration (w/ SSD, according to IEC60068-2-27)
EMC	CE/FCC Class A, according to EN 55022, EN 55024 & EN 55032

* For i7-6700 running at 65W mode, the high operating temperature shall be limited to 50°C and thermal throttling may occur when sustained full-loading applied. Users can configure CPU power in BIOS to obtain higher operating temperature.
** For sub-zero operating temperature, a wide temperature HDD drive or Solid State Disk (SSD) is required.

Appearance

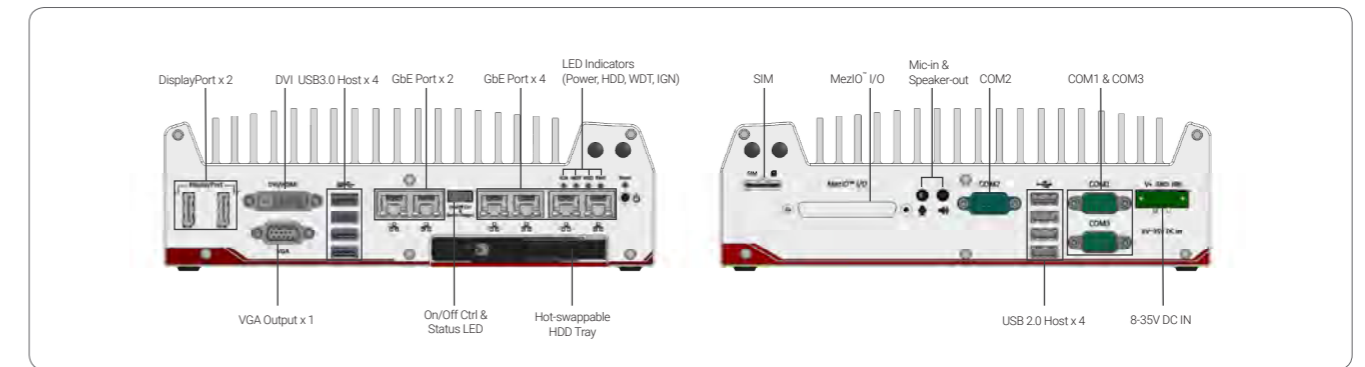

Dimensions

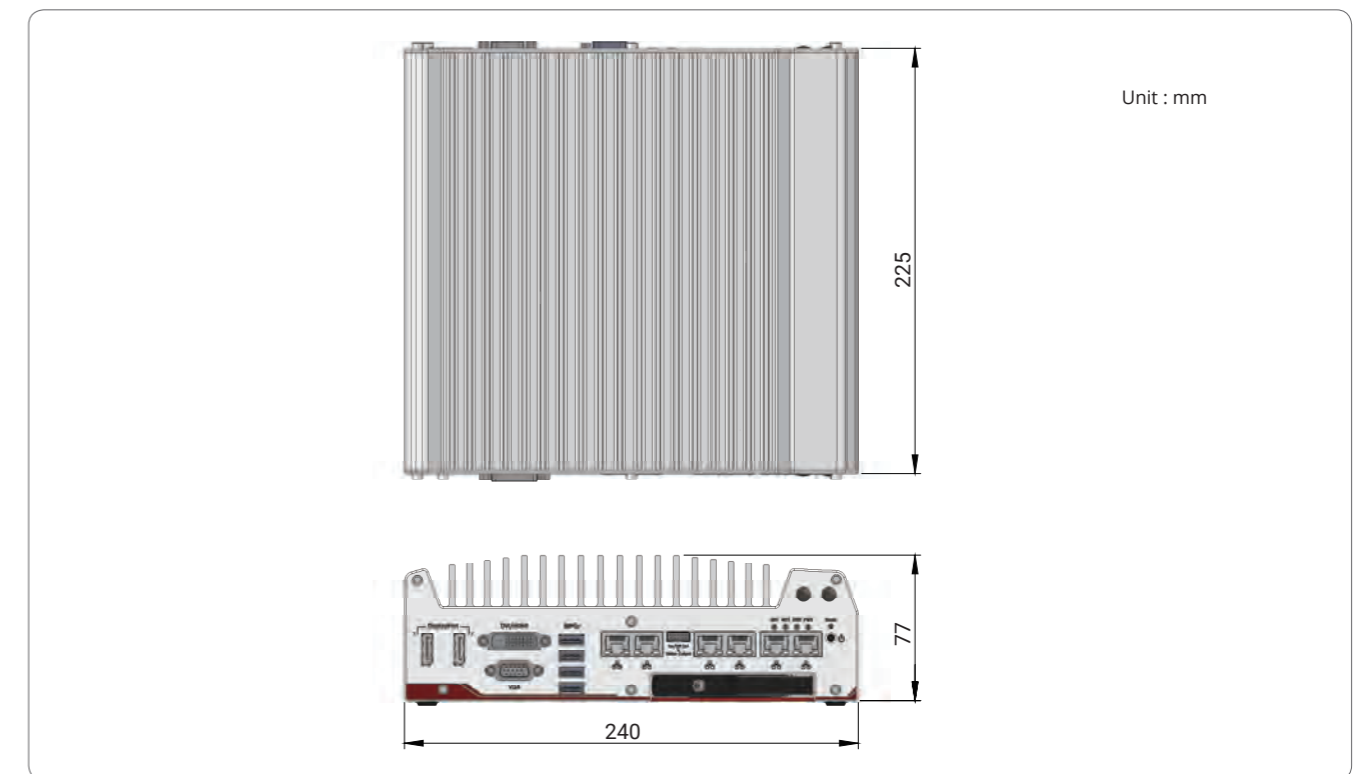

Ordering Information

Model No.	Product Description
Nuvo-5002LP	Intel® 6th-Gen Core™ low-profile fanless controller with 2x GbE and MezIO™
Nuvo-5006LP	Intel® 6th-Gen Core™ low-profile fanless controller with 6x GbE and MezIO™
Optional 802.3at PoE+ for GbE ports 3 ~ 6	

Optional Accessories

DINRAIL-O	DIN-rail mounting assembly for Nuvo-5000LP series
PA-120W-OV	120W AC/DC power adapter 20V/6A; 18AWG/120cm; cord end terminals for terminal block, operating temperature : -30 to 70 °C.

MezIO™ Modules

MezIO™-C180	MezIO™ module with 4x RS-232/ 422/ 485 ports and 4x RS-232 ports	MezIO™-V20-EP	MezIO™ module with ignition power control function for in-vehicle application
MezIO™-C181	MezIO™ module with 4x RS-232/ 422/ 485 ports and 4x RS-422/ 485 ports	MezIO™-U4	MezIO™ module with 4x USB3.0 ports
MezIO™-D220	MezIO™ module with 8-CH isolated digital input and 8-CH isolated digital output	MezIO™-G4	MezIO™ module with 4x GigE ports
MezIO™-D230	MezIO™ module with 16-CH isolated digital input and 16-CH isolated digital output	MezIO™-G4P	MezIO™ module with 4x IEEE 802.3at PoE ports

Nuvo-3000E/P Series

Intel® 3rd-Gen Core™ i7/ i5/ i3 Fanless Controller with 5x GbE, 4x USB3.0 and Expansion Cassette



Key Features

- Intel® 3rd-Gen Core™ i7 quad-core processor
- Patented Cassette* design for PCIe/ PCI add-on card expansion
- Up to 5x GigE ports, supporting 9.5 KB jumbo frame
- Rugged, -25°C to 70°C fanless operation
- Optional intelligent ignition power control for in-vehicle application
- VGA/ DVI dual display outputs
- 4x USB3.0 ports + 4x USB2.0 ports
- Optional isolated DIO with Change-of-State interrupt support



*R.O.C Patent No. M456527

Introduction

Nuvo-3000E/ 3000P series is a reliable and versatile embedded controller that features Intel® 3rd-Gen Core™ i7 processor technology and Neosys' innovative Cassette architecture. The 3rd-Gen Core™ i7 processor delivers tremendous computing power and graphics performance. This platform also natively supports USB3.0, DDR3-1600 and SATA3.

Inheriting the heritage of proven Nuvo series, Nuvo-3000E/ 3000P is extremely reliable mechanically and allows -25°C to 70°C operating temperature. Moreover, it comes with Neosys' patented Cassette design. This unique expansion Cassette offers PCI/ PCIe slot with minimal thermal interference between system and add-on card.

I/O functions on Nuvo-3000E/ 3000P are versatile. Gigabit Ethernet, USB3.0 and dual display outputs are natively supported on Nuvo-3000E/3000P. Its optional isolated digital I/O now supports Change-of-State interrupt for more usability. There is also an option to add-on intelligent ignition control for in-vehicle applications.

With Intel 3rd-Gen Core™ i7's computing performance, innovative Cassette for expandability and ignition control bringing in-vehicle mobility, Nuvo-3000E/3000P is ready for various application requirements.

Specifications

System Core	
Processor	Intel® Core™ i7-3610QE (2.3/ 3.3 GHz, 6 MB cache) Intel® Core™ i5-3610ME (2.7/ 3.3 GHz, 3 MB cache) Intel® Celeron™ 1020E (2.2 GHz, 2 MB cache)
Chipset	Intel® HM76 platform controller hub
Graphics	Integrated Intel® HD graphics 4000 controller (i7/ i5) Integrated Intel® HD graphics controller (Celeron)
Memory	Up to 16GB DDR3 1333/ 1600 MHz SDRAM (two SO-DIMM slots)
I/O Interface	
Ethernet	5x Gigabit Ethernet ports by Intel® I210 (Nuvo-3005E/ P) 3x Gigabit Ethernet ports by Intel® I210 (Nuvo-3003E/ P)
PoE	Option of PoE capability for 4xGbE
Video Port	1x DB-15 connector for analog RGB, supporting 2048x1536 resolution 2x DVI-D connectors for DVI outputs, supporting 1920x1200 resolution (dual-independent display support)
USB	4x USB3.0 ports and 4x USB2.0 ports
Serial Port	2x software-programmable RS-232/ 422/ 485 (COM1 & COM2)
Isolated DIO (Optional)	8x isolated DI with COS interrupt and 8x isolated DO
KB/MS	1x 6-pin mini-DIN connector for PS/ 2 keyboard/mouse
Audio	1x Mic-in and 1x speaker-out
Storage Interface	
SATA HDD	1x Internal SATA port for 2.5" HDD/ SSD installation
CFast	1x CFast socket
Expansion Bus	
PCI/PCI Express	1x PCI slot in Cassette (Nuvo-3003P/ 3005P) 1x PCIe x16 slot @ 8-lanes PCIe signals in Cassette (Nuvo-3003E/ 3005E)
Mini PCI-E	1x internal mini PCI Express socket with USIM socket 1x internal mini PCI Express socket
Power Supply & Ignition Control	
DC Input	1x 4-pin power connector for 8-25V DC input (for AC adapter) 1x 3-pin pluggable terminal block for 8-25V DC input (for direct DC wiring)
Ignition Control	Optional ignition power control with configurable on/ off delay
Remote Ctrl. & Status Output	1x 10-pin (2x5) wafer connector for remote on/ off control and status LED output
Power Consumption	With i7-3610QE : 72.96W (3.84A@19V) With i5-3610ME : 48.83W (2.57A@19V)
Mechanical	
Dimension	240mm (W) x 225mm (D) x 90mm (H)
Weight	4.4kg (including CPU, memory and HDD)
Mounting	Wall-mounting (standard) or DIN-rail mounting (optional)
Environmental	
Operating Temperature	-25°C ~ 70°C **/*** (with i5-3610ME & Celeron 1020E) -25°C ~ 60°C **/*** (with i7-3610QE)
Storage Temperature	-40°C ~ 85°C
Humidity	10%~90% , non-condensing
Vibration	Operating, 5Grms, 5-500 Hz, 3 Axes (w/ SSD, according to IEC60068-2-64)
Shock	Operating, 50Grms, Half-sine 11ms Duration (w/ SSD, according to IEC60068-2-27)
EMC	CE/ FCC Class A, according to EN 55022 & EN 55024

*100% CPU loading is applied using Intel® Thermal Analysis Tool. For detail testing criteria, please contact Neosys Technology.
**For sub-zero operating temperature, a wide temperature HDD drive or Solid State Disk (SSD) is required.

Appearance

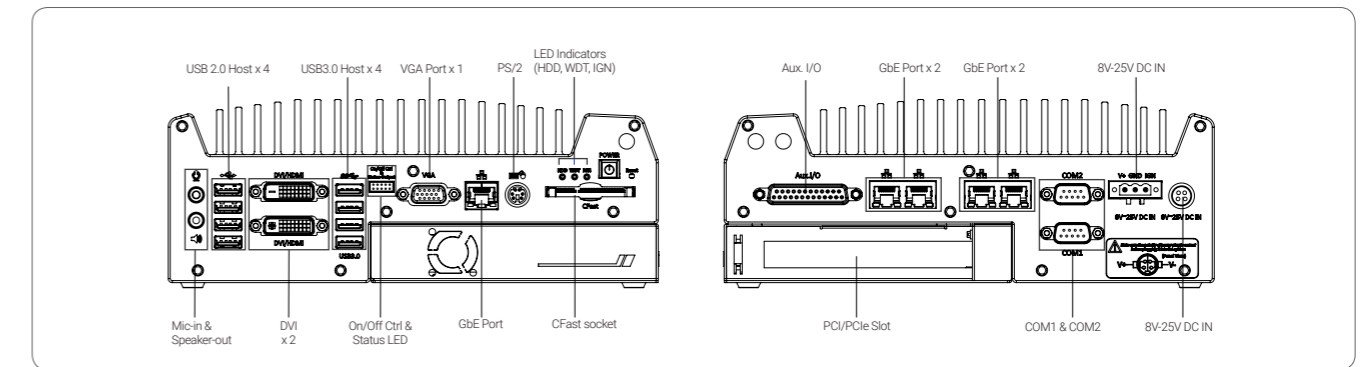

Dimensions

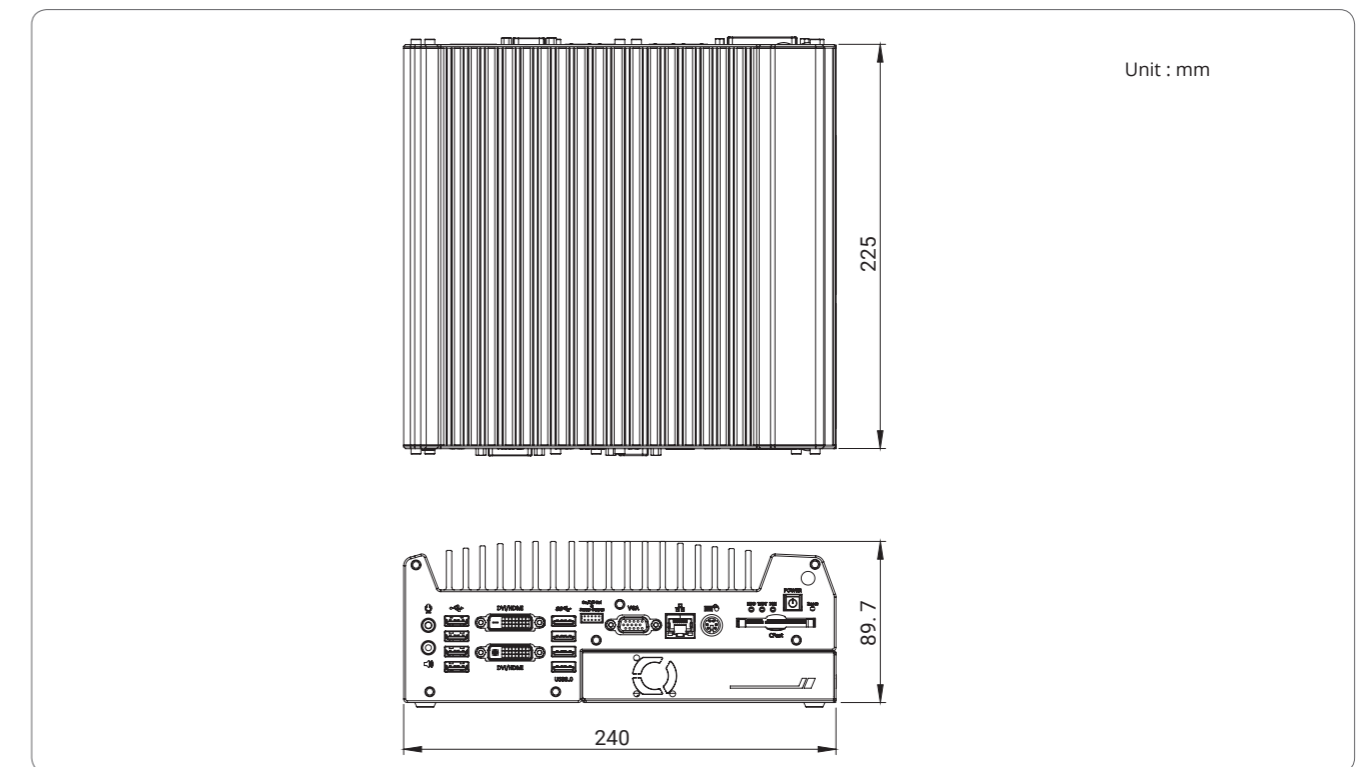

Ordering Information

Model No.	Product Description
Nuvo-3003E	Intel® 3rd-Gen Core™ i fanless controller with 3x GbE, 4x USB3.0 and 16x PCI Express Cassette (@ x8 signals)
Nuvo-3003P	Intel® 3rd-Gen Core™ i fanless controller with 3x GbE, 4x USB3.0 and PCI Cassette
Nuvo-3005E	Intel® 3rd-Gen Core™ i fanless controller with 5x GbE, 4x USB3.0 and 16x PCI Express Cassette (@ x8 signals)
Nuvo-3005P	Intel® 3rd-Gen Core™ i fanless controller with 5x GbE, 4x USB3.0 and PCI Cassette
<i>Option of isolated DIO (8DI + 8DO) (Nuvo-3005E/ P only)</i>	
<i>Option of ignition power control (Nuvo-3005E/ P only)</i>	
<i>Option of 802.3af PoE for 4x GbE (Nuvo-3005E/ P only)</i>	

Optional Accessories

DINRAIL-O	DIN-rail mounting assembly for Nuvo-3000 series
PA-120W-OW	120W AC/DC power adapter 20V/6A; 18AWG/120cm; cord end terminals for terminal block, operating temperature : -30 to 70 °C.
Fan-25	Fan assembly for 1-slot Cassette, 25x25x10 mm

Cassette Modules

CSM-PoE354	Cassette module with PCIe-PoE354at and pre-installed passive heat-spreader
CSM-USB380	Cassette module with PCIe-USB380 and pre-installed passive heat-spreader
CSM-NV730	Cassette module with NVIDIA® GTX 730 graphics card, pre-installed heat-spreader and fan

Nuvo-3005LP

Intel® 3rd-Gen Core™ i7/ i5 Low Profile Fanless Embedded System with Swappable HDD Tray



CE FC

Key Features

- Intel® 3rd-Gen Core™ i7 quad-core processor
- 240mm x 225mm x 69mm low-profile chassis
- One easy-swap 2.5" HDD and one fixed 2.5" HDD
- Up to 5x GigE ports, supporting 9.5 KB jumbo frame
- Rugged, -25°C to 70°C fanless operation
- Optional PoE port functionality
- Optional isolated DIO with COS interrupt support

Introduction

The low profile chassis of Nuvo-3005LP is ideal for deployment in confined spaces. The low profile chassis is only 69mm in height and yet remains extremely thermal efficient with extraordinary reliability in a -25°C to 70°C operating temperature range.

Nuvo-3005LP incorporates Intel® 3rd-Gen Core™ i7 quad-core processor with versatile I/O functions such as Gigabit Ethernet ports, USB3.0 ports and dual independent display outputs. As options, it offers Power over Ethernet (PoE), isolated DIO and ignition power control for a wider range of applications.

Its newly-designed chassis offers one fixed 2.5" HDD accommodation and one easy-swap 2.5" HDD tray. Users can take advantage of its storage design for applications that requires frequent HDD replacement. Combing its low-profile chassis and PoE option, Nuvo-3005LP is a suitable platform for advanced surveillance/ security systems.

Specifications

System Core	
Processor	Intel® Core™ i7-3610QE (2.3/ 3.3 GHz, 6 MB cache) Intel® Core™ i5-3610ME (2.7/ 3.3 GHz, 3 MB cache) Intel® Celeron® 1020E (2.2 GHz, 2 MB cache)
Chipset	Intel® HM76 Platform Controller Hub
Graphics	Integrated Intel® HD Graphics 4000 Controller (i7/ i5) Integrated Intel® HD Graphics Controller (Celeron®)
Memory	Up to 16GB DDR3 1333/ 1600 MHz SDRAM (two SO-DIMM slots)
I/O Interface	
Ethernet	5x Gigabit Ethernet ports by Intel® I210
PoE	Option of PoE capability for 4x GbE
Video Port	1x DB-15 connector for analog RGB, supporting 2048x1536 resolution 2x DVI-D connectors for DVI outputs, supporting 1920x1080 resolution (dual-independent display support)
USB	2x USB3.0 ports and 2x USB2.0 ports
Serial Port	1x software-programmable RS-232/ 422/ 485 (COM1)
Isolated DIO (Optional)	8x isolated DI with COS interrupt and 8x isolated DO
KB/MS	1x 6-pin mini-DIN connector for PS/2 keyboard/ mouse
Audio	1x Mic-in and 1x speaker-out
Storage Interface	
SATA HDD	1x Internal SATA port for 2.5" HDD/ SSD installation 1x easy-swap HDD tray for 2.5" HDD/ SSD installation
CFast	1x CFast socket
Expansion Bus	
Mini PCI-E	1x internal mini PCI Express socket with USIM socket 1x internal mini PCI Express socket
Power Supply & Ignition Control	
DC Input	1x 4-pin power connector for 8-25V DC input (for AC adapter) 1x 3-pin pluggable terminal block for 8-25V DC input (for direct DC wiring)
Ignition Control	1x 3-pin pluggable terminal block for ignition signal input (IGN/ GND/ V+) (Optional)
Remote Ctrl. & Status Output	1x 10-pin (2x5) wafer connector for remote on/off control and status LED output
Power Consumption	With i7-3610QE : 72.96W (3.84A@19V) With i5-3610ME : 48.83W (2.57A@19V)
Mechanical	
Dimension	240mm (W) x 225mm (D) x 69mm (H)
Weight	3.4 kg (incl. CPU, memory and HDD)
Mounting	Wall-mounting (standard) or DIN-rail mounting (optional)
Environmental	
Operating Temperature	-25°C ~ 70°C */** (with i5-3610ME & Celeron 1020E) -25°C ~ 60°C */** (with i7-3610QE)
Storage Temperature	-40°C ~ 85°C
Humidity	10%~90% , non-condensing
Vibration	Operating, 5Grms, 5-500 Hz, 3 Axes (w/ SSD, according to IEC60068-2-64)
Shock	Operating, 50Grms, Half-sine 11ms Duration (w/ SSD, according to IEC60068-2-27)
EMC	CE/FCC Class A, according to EN 55022 & EN 55024

*100% CPU loading is applied using Intel® Thermal Analysis Tool. For detail testing criteria, please contact Neousys Technology.
**For sub-zero operating temperature, a wide temperature HDD drive or Solid State Disk (SSD) is required.

Appearance

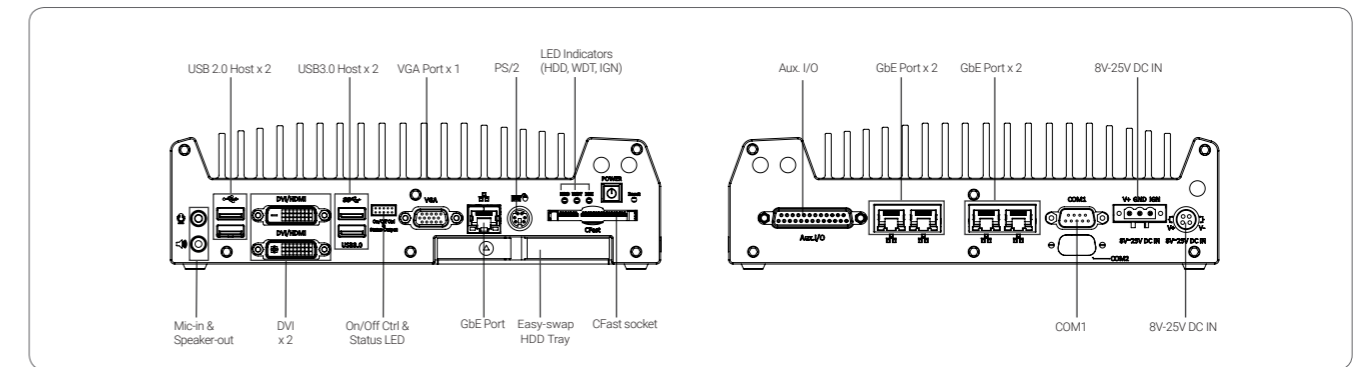

Dimensions

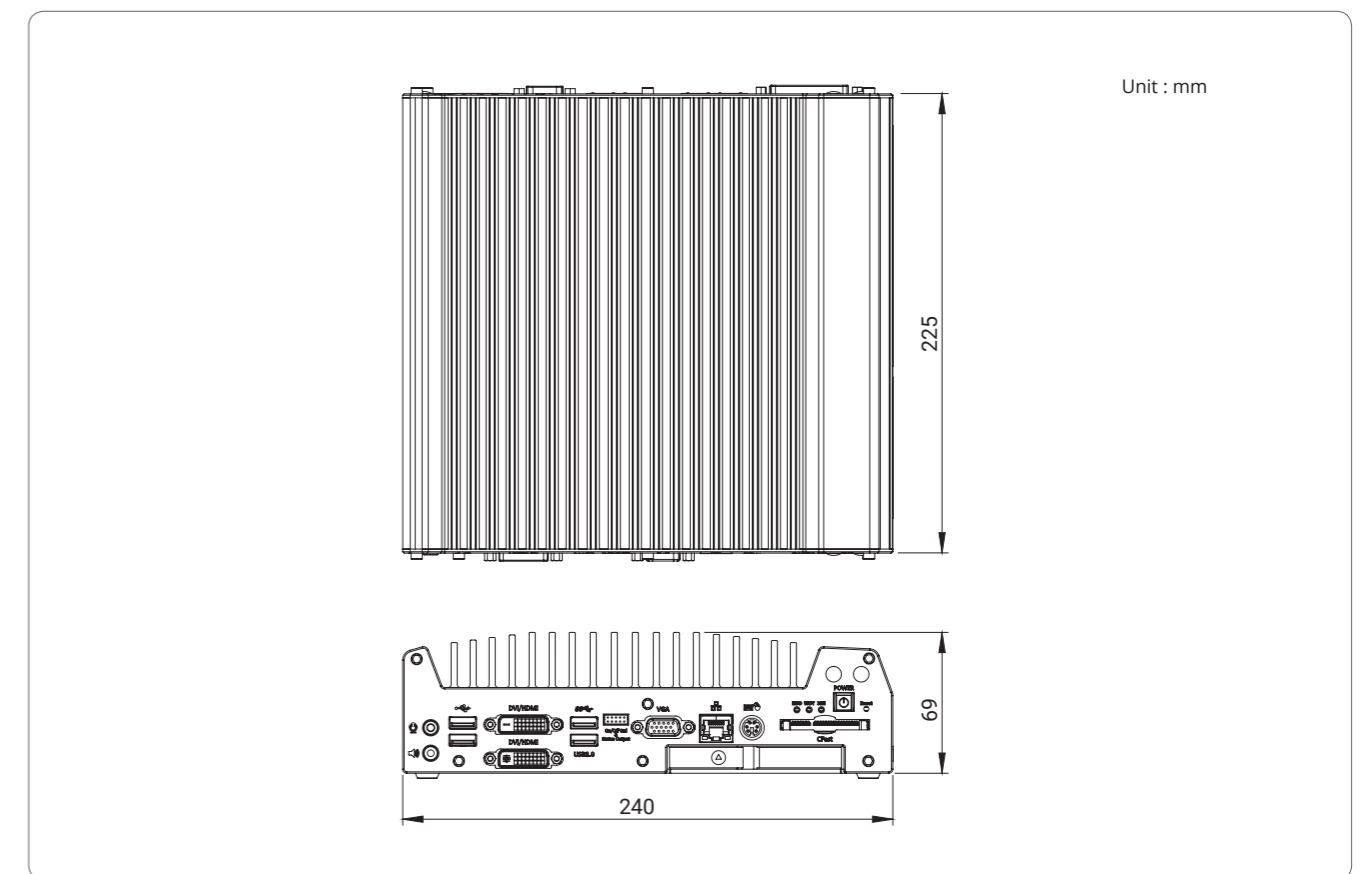

Ordering Information

Model No.	Product Description
Nuvo-3005LP	Intel® 3rd-Gen Core™ i fanless embedded controller with 5x GbE, 2x USB3.0, 2x USB2.0, dual SATA ports and low-profile chassis
	<i>Option of ignition power control</i>
	<i>Option of isolated DIO(8DI + 8DO)</i>
	<i>Option of PoE capability for 4x GbE</i>

Optional Accessories

DINRAIL-O	DIN-rail mounting assembly for Nuvo-3000 series
PA-120W-OW	120W AC/DC power adapter 20V/6A; 18AWG/120cm; cord end terminals for terminal block, operating temperature : -30 to 70 °C.

Nuvo-3005TB

Intel® 3rd-Gen Core™ i7 /i5/ i3 Fanless Embedded Controller with 3.5" Storage Capacity



Key Features

- Intel® 3rd-Gen Core™ i7 quad-core processor
- Wide temperature -25°C to 70°C operation
- Up to 5x GigE ports, supporting 9.5 KB jumbo frame
- Rugged, -25°C to 70°C fanless operation
- Supports one 3.5" HDD and one 2.5" HDD
- 4x USB3.0 ports + 4x USB2.0 ports
- Option of isolated DIO with Change-of-State interrupt support



Introduction

Nuvo-3005TB are embedded versions of Nuvo-3000 series. They allow installation of one 3.5" HDD supporting the latest terabyte storage capacity in an embedded platform with superior reliability and durability.

Nuvo-3005TB incorporates Intel® 3rd-Gen Core™ i7 quad-core processor and versatile I/O functions such as Gigabit Ethernet ports, USB3.0 ports and dual display outputs. As options, it offers isolated DIO with COS (Change-of-State) interrupt support for wider range of applications.

Inside its compact chassis, Nuvo-3005TB/ 3003TB can accommodate one 2.5" HDD/ SSD and one 3.5" HDD supporting the latest terabyte storage capacity. A dedicated shock-absorbing bracket is designed to protect 3.5" HDD from shock/ vibration, and a unique isolation/ conduction chamber is used to manage heat generated by 3.5" HDD and increase overall system stability.

Specifications

System Core		Expansion Bus	
Processor	Intel® Core™ i7-3610QE (2.3/ 3.3 GHz, 6 MB cache) Intel® Core™ i5-3610ME (2.7/ 3.3 GHz, 3 MB cache) Intel® Celeron® 1020E (2.2 GHz, 2 MB cache)	Mini PCI-E	1x internal mini PCI Express socket with USIM socket 1x internal mini PCI Express socket
Chipset	Intel® HM76 Platform Controller Hub	Power Supply & Ignition Control	
Graphics	Integrated Intel® HD Graphics 4000 Controller (i7 /i5) Integrated Intel® HD Graphics Controller (Celeron)	DC Input	1x 4-pin power connector for 8-25V DC input (for AC adapter) 1x 3-pin pluggable terminal block for 8-25V DC input (for direct DC wiring)
Memory	2x 204-pin SO-DIMM sockets, up to 16GB DDR3 1333/1600 MHz SDRAM	Remote Ctrl. & Status Output	1x 10-pin (2x5) wafer connector for remote on/off control and status LED output
I/O Interface		Power Consumption	With i7-3610QE : 72.96W (3.84A@19V) With i5-3610ME : 48.83W (2.57A@19V)
Ethernet	5x Gigabit Ethernet ports by Intel® I210	Mechanical	
PoE (Optional)	Option of PoE capability for 4x GbE	Dimension	240mm (W) x 225mm (D) x 86mm (H)
Video Port	1x DB-15 connector for analog RGB, supporting 2048x1536 resolution 2x DVI-D connectors for DVI outputs, supporting 1920x1080 resolution (dual-independent display support)	Weight	3.4 kg (incl. CPU, memory and HDD)
USB	4x USB3.0 ports and 4x USB2.0 ports	Mounting	Wall-mounting (standard) or DIN-rail mounting (optional)
Serial Port	2x software-programmable RS-232/422/485 (COM1 & COM2)	Environmental	
Isolated DIO (Optional)	8x isolated DI with COS interrupt and 8x isolated DO	Operating Temperature	-25°C ~ 70°C ** (with i5-3610ME & Celeron 1020E) -25°C ~ 60°C ** (with i7-3610QE)
KB/MS	1x 6-pin mini-DIN connector for PS/2 keyboard/mouse	Storage Temperature	-40°C ~ 85°C
Audio	1x Mic-in and 1x speaker-out	Humidity	10%-90% , non-condensing
Storage Interface		Vibration	Operating, 5Grms, 5-500 Hz, 3 Axes (w/ SSD, according to IEC60068-2-64)
SATA HDD	1x internal SATA port for 2.5" HDD/ SSD installation 1x internal SATA port for 3.5" HDD installation	Shock	Operating, 50Grms, Half-sine 11ms Duration (w/ SSD, according to IEC60068-2-27)
CFast	1x CFast socket	EMC	CE/FCC Class A, according to EN 55022 & EN 55024

*100% CPU loading is applied using Intel® Thermal Analysis Tool. For detail testing criteria, please contact Neosys Technology.
**For sub-zero operating temperature, a wide temperature HDD drive or Solid State Disk (SSD) is required.

Appearance

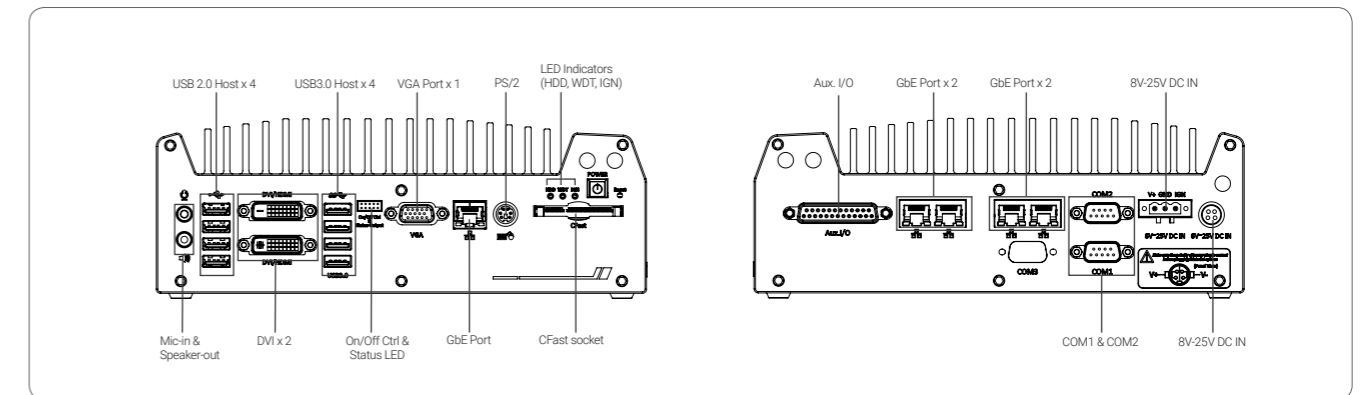

Dimensions

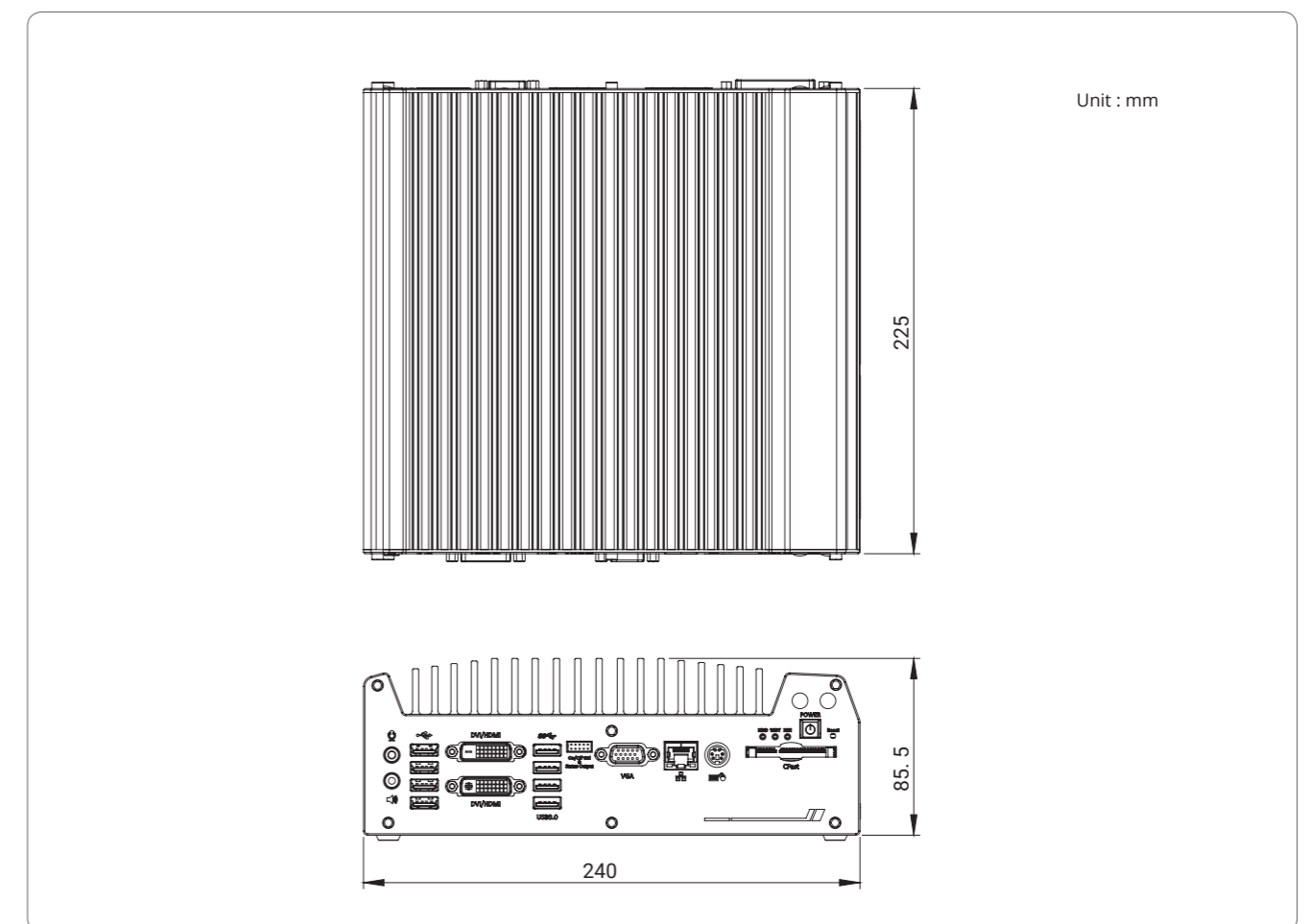

Ordering Information

Model No.	Product Description
Nuvo-3005TB	Intel® 3rd-Gen Core™ i fanless embedded controller with 5x GbE, 4x USB3.0, dual SATA ports and 3.5" HDD accommodation
	<i>Option of isolated DIO(8DI + 8DO)</i>
	<i>Option of PoE capability for 4x GbE</i>

Optional Accessories

DINRAIL-O	DIN-rail mounting assembly for Nuvo-3000 series
PA-120W-OW	120W AC/DC power adapter 20V/6A; 18AWG/120cm; cord end terminals for terminal block, operating temperature : -30 to 70 °C.

Nuvo-3120

Compact Intel® 3rd-Gen Core™ i7/ i5 Fanless Controller with Configurable CPU Power Mode



CE FC

Key Features

- 212mm x 165mm x 62mm compact size
- Intel® 3rd-Gen Core™ i7/ i5 PGA-type processor
- User-configurable CPU power mode for adaptation to various environments
- Dual GbE ports and four USB3.0 ports
- DVI/VGA + DisplayPort triple independent display outputs
- Built-in isolated digital I/O with Change-of-State (COS) interrupt
- 8 ~ 35V wide-range DC input

Introduction

It is one of the most compact fanless controllers supporting Intel® 3rd-Gen Core™ i7/ i5 PGA-type processor, Neosys Nuvo-3120's footprint measures just 212 mm x 165 mm x 62mm. While other compact fanless controllers adopt low-voltage BGA-type Core™ i7 CPU (17W), Nuvo-3120 supports standard voltage PGA-type Core™ i7/ i5 CPUs (45W/ 35W) for better computation power and flexible CPU selection. A unique feature, configurable CPU power mode, is developed to balance the trade-off between heat-sink size and operating temperature. According to ambient conditions, you can configure Nuvo-3120 to operate in Maximum Performance, reduced performance or extended temperature mode. Regardless of its' compact dimensions, the system still has plenty of I/O functions such as Gigabit Ethernet, USB3.0, SATA, COM port, mini-PCIe and isolation DIO. It also supports triple-independent display outputs to benefit image-related applications. Compact yet powerful, Nuvo-3120 meets all your embedded controller needs.

Specifications

System Core		Power Supply & Ignition Control		
Processor	Intel® Core™ i7-3610QE (2.3/ 3.3 GHz, 6 MB cache) Intel® Core™ i5-3610ME (2.7/ 3.3 GHz, 3 MB cache) Intel® Celeron® 1020E (2.2 GHz, 2 MB cache)	DC Input	1x 3-pin pluggable terminal block for 8~35V DC input	
Chipset	Intel® HM76 Platform Controller Hub	Ignition Control (Optional)	Ignition power control with user-selectable on/off delay	
Graphics	Integrated Intel® HD Graphics 4000 Controller	Power Consumption	With i7-3610QE : 72.96W (3.84A@19V) With i5-3610ME : 48.83W (2.57A@19V)	
Memory	Up to 8GB DDR3 1333/ 1600 MHz SDRAM (single SO-DIMM slot)	Mechanical		
I/O Interface		Dimension	212mm (W) x 165mm (D) x 62mm (H)	
Ethernet	1x Gigabit Ethernet port by Intel® 82579LM, supporting Wake-on-LAN 1x Gigabit Ethernet ports by Intel® i210	Weight	2.7kg (incl. CPU, memory and HDD)	
Video Port	1x DVI-I connector for VGA/DVI output, supporting 2048x1536 (VGA) or 1920x1080 (DVI) resolution 2x DisplayPort, supporting 2560x1600 resolution (triple-independent display support)	Mounting	Wall-mounting (standard) or DIN-rail mounting (optional)	
USB	4x USB3.0 ports and 2x USB2.0 ports	Environmental		
Serial Port	2x software-programmable RS-232/ 422/ 485 (COM1 & COM2)	Operating Temperature	Maximum Performance	-25°C ~ 50°C**
Isolated DIO	4x isolated DI with COS interrupt and 4x isolated DO	Reduced Performance	-25°C ~ 60°C**	-25°C ~ 70°C**
Audio	1x Mic-in and 1x speaker-out	Extended Temperature	-25°C ~ 70°C**	-25°C ~ 70°C**
Storage Interface		Storage Temperature	-40°C ~ 85°C	
SATA HDD	1x Internal SATA port for 2.5" HDD/ SSD	Humidity	10%~90% , non-condensing	
mSATA	1x full-size mSATA (SATA/USB/W_DISABLE#) with USIM socket	Vibration	Operating, 5Grms, 5-500 Hz, 3 Axes (w/ SSD, according to IEC60068-2-64)	
Expansion Bus		Shock	Operating, 50Grms, Half-sine 11ms Duration (w/ SSD, according to IEC60068-2-27)	
Mini PCI-E	1x full-size mini PCI Express socket with USIM socket 1x half-size mini PCI Express socket	EMC	CE/FCC Class A, according to EN 55022 & EN 55024	

* The 100% CPU loading is applied using Passmark® BurnInTest™ v7.0. For detail testing criteria, please contact Neosys Technology
** For sub-zero operating temperature, a wide temperature HDD drive or Solid State Disk (SSD) is required.

Appearance

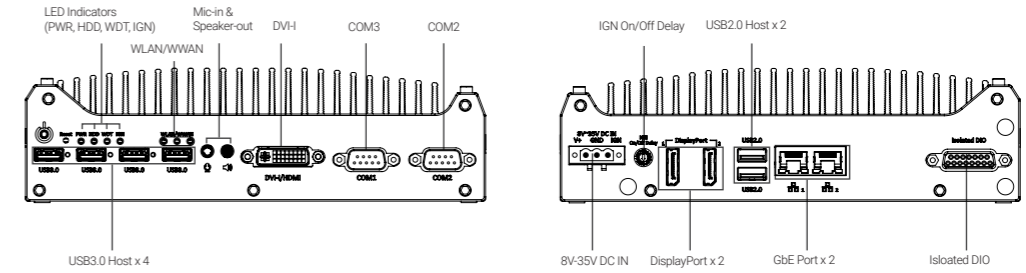

Dimensions

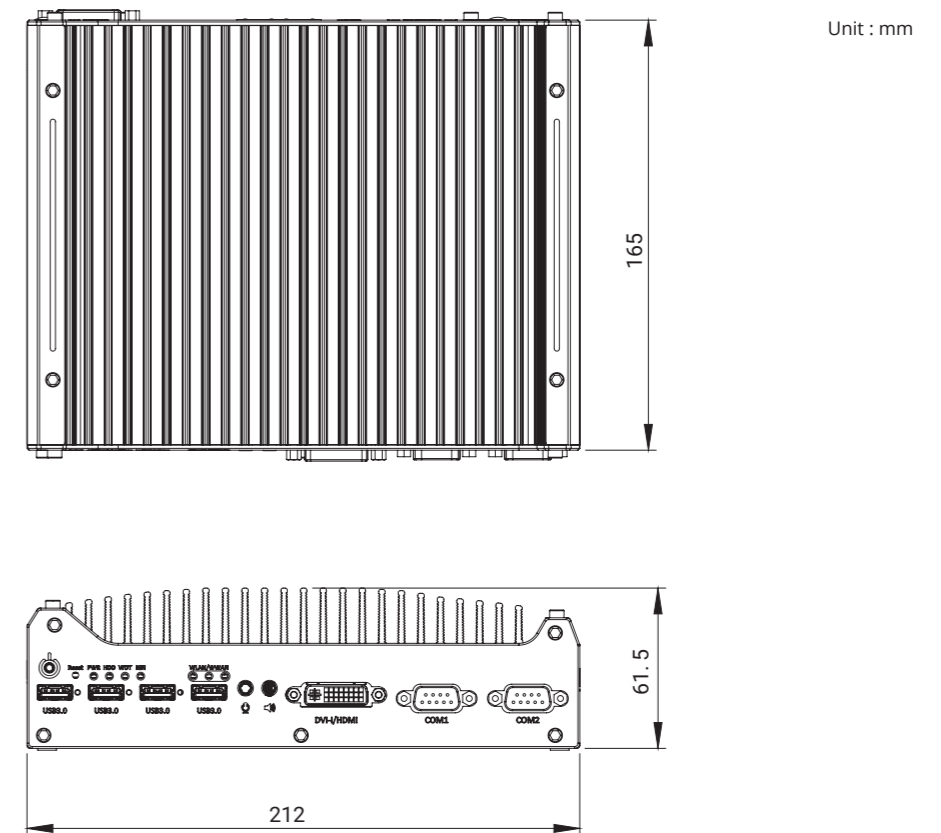

Ordering Information

Model No.	Product Description
Nuvo-3120	Intel® 3rd-Gen Core™ i fanless embedded controller with 2x GbE, 4x USB3.0, compact size and configurable CPU power mode
	Optional ignition power control

Optional Accessories

DINRAIL-31	DIN-rail mounting assembly for Nuvo-3120 series
PA-120W-OW	120W AC/DC power adapter 20V/6A; 18AWG/120cm; cord end terminals for terminal block, operating temperature : -30 to 70 °C.

Nuvo-2500E/P Series

Intel® Celeron® Bay Trail Fanless Computer with Expansion Cassette



Key Features

- Intel® Celeron® Bay Trail J1900 quad-core processor
- Compact 1x PCI/ PCIe expansion
- Rugged, -25°C to 70°C fanless operation
- Dual storage with 1x mSATA and 1x SATA
- Dual independent display via VGA and DVI connectors
- 2x RS-232/ 422/ 485 + 2x RS-232
- Optional MAIO for DI/O, PWM and encoder signals
- 8 to 35V DC wide-range DC input

*R.O.C Patent No. M456527

Introduction

Nuvo-2500 series are general purpose fanless computers with Intel® Bay Trail processor. Powered by the quad-core Bay Trail processor, Nuvo-2500 shows outstanding computing power and is more power efficient compared to its predecessors. Nuvo-2500 supports dual independent display, dual storage for isolating system and data, 2x Gigabit Ethernet ports, 4x COM ports and 4x USB ports.

With one PCI or PCIe expansion slot, Nuvo-2500 still retains its compact dimensions measuring just 205mm (W) x 146mm (D) x 76mm (H). The PCI or PCIe expansion slot is situated in Neosys Patented expansion Cassette. The patented design significantly reduces thermal impact from the installed add-on card thus making Nuvo-2500 extremely reliable and stable under harsh environments.

Wireless communication such as 3G, LTE, Wi-Fi and BT are supported by internal Mini PCIe socket with USIM socket. As an option, Nuvo-2500 can be equipped with Auxiliary I/O. The Auxiliary I/O includes 4x isolated digital inputs, 8x isolated digital outputs, 6x PWM outputs, 1x quadrature encoder input and 2x ADC. The Auxiliary I/O facilitates simple sequence and speed control for various types of motors making Nuvo-2500 the perfect controller for your versatile equipment.

Specifications

System Core		Expansion Bus	
Processor	Intel® Celeron® Bay Trail J1900 quad-core processor (2.42 GHz, 2M cache)	Mini PCI-E	1x full-size mini PCI Express socket with USIM holder (PCIe x1 Gen2 and USB2 signal) 1x full-size mini PCI Express socket (USB signal)
Graphics	Integrated Intel® HD graphics	PCIe (Nuvo-2500E)	1x PCI Express x4 slot with 1-lane Gen2 PCI Express Signal, supporting max. card size up to 173mm (W) x 121mm (H)
Memory	Up to 8GB DDR3L 1333MHz SDRAM (single SO-DIMM slot)	PCI (Nuvo-2500P)	1x PCI Slot with 33MHz/33-bit PCI, supporting max. card size up to 173mm (W) x 121mm (H)
Front Panel I/O Interface		Power Supply	
Ethernet	2x Gigabit Ethernet by Intel® Ethernet Controller I210	DC Input	8~35V DC
Video Port	1x VGA output, supporting resolution up to 2560 x 1600	Mechanical	
Serial Port	2x BIOS-Configurable RS-232/ 422/ 485 (COM1 & COM2)	Dimension	205 mm (W) x 146 mm (D) x 73 mm (H)
USB	1x USB3.0 and 3x USB2.0	Weight	2.3 kg (incl. CPU, memory and HDD)
Power Input	1x 3-pin pluggable terminal block for DC input	Mounting	Wall-mounting (standard) or DIN-rail mounting (optional)
Back Panel I/O Interface		Environmental	
Video Port	1x DVI-D output via DVI-I connector, supporting resolution up to 2560 x 1600	Operating Temperature	-25°C ~ 70°C with SSD, 100% CPU loading */**
Series Port	2x RS-232 (COM3 & COM4)	Storage Temperature	-40°C ~ 85°C**
Audio	1x Mic-in and 1x speaker-out	Humidity	10%~90% , non-condensing
Aux I/O Port	1x DB37 connector 1x DB-37 female connector 4x DI and 8x DO, 6x PWM, 1x encoder and 2x voltage inputs are available as an option of MAIO	Vibration	Operating, 5 Grms, 5-500 Hz, 3 Axes (w/ SSD, according to IEC60068-2-64)
Back Panel I/O Interface		Shock	Operating, 50 Grms, Half-sine 11 ms Duration (w/ SSD, according to IEC60068-2-27)
SATA 2.0	1x Internal SATA port for 2.5" HDD/SSD installation	EMC	CE/FCC Class A, according to EN 55022 & EN 55024
mSATA	1x internal half-sized mSATA (SATA + USB)		

* The 100% CPU loading is applied using Passmark® BurnInTest™ v7.0. For detail testing criteria, please contact Neosys Technology
** For sub-zero operating temperature, a wide temperature HDD drive or Solid State Disk (SSD) is required.

Appearance

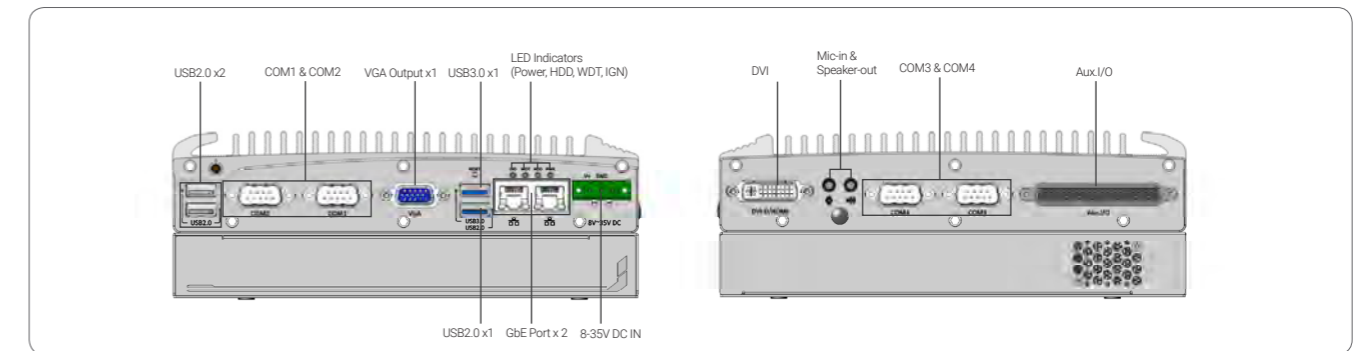

Dimensions

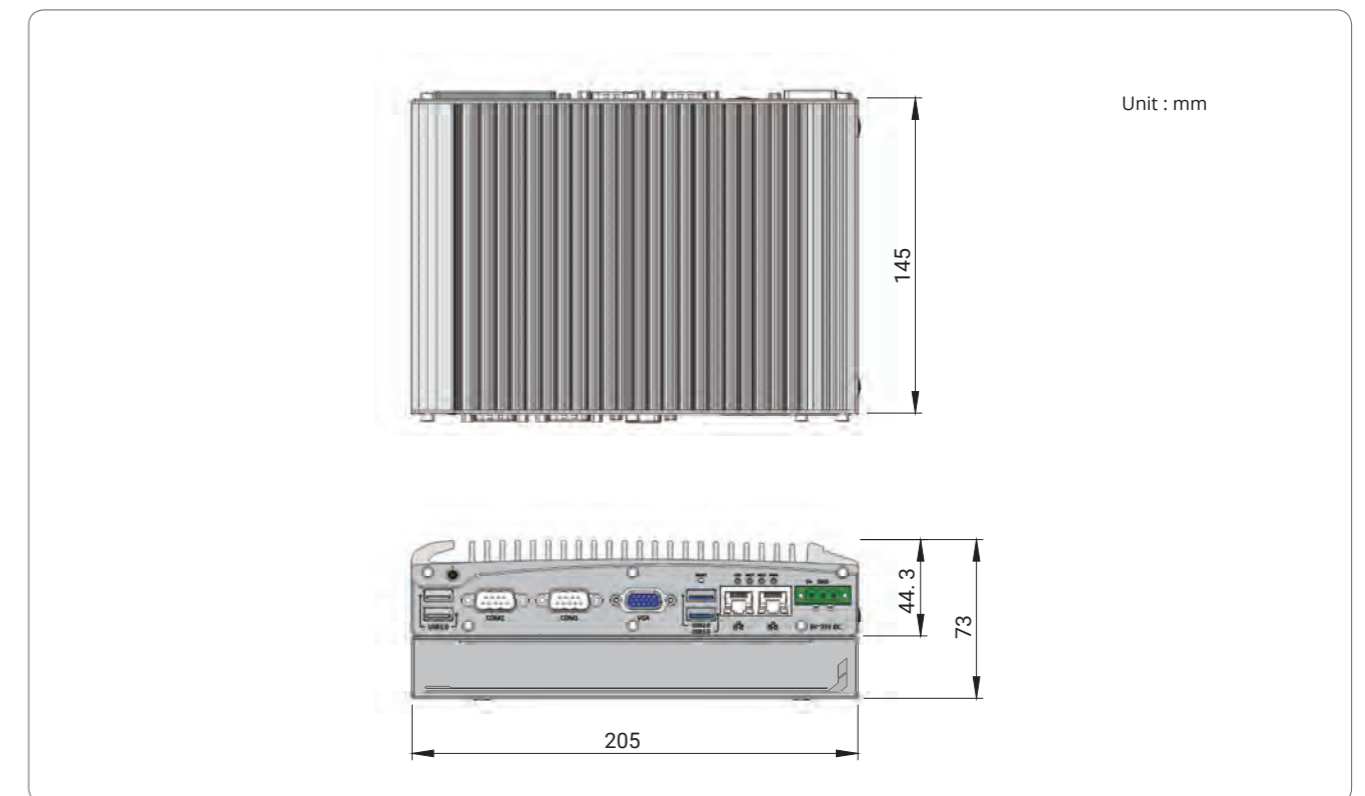

Ordering Information

Model No.	Product Description
Nuvo-2500P	Intel® Bay Trail Celeron® J1900 fanless embedded controller with 1x PCI slot in Neosys patented Cassette
Nuvo-2500E	Intel® Bay Trail Celeron® J1900 fanless embedded controller with 1x PCIe x4 slot (@ x1 signals) in Neosys patented Cassette
Option of 802.3af PoE for 2 GbE	
Option of MAIO (4x DI, 8x DO, 6xPWM, 1x encoder and 2x voltage input)	

Optional Accessories

Fan-25	Fan assembly for 1-slot Cassette, 25x25x10 mm
DINRAIL-25	DIN-rail mounting assembly for Nuvo-2500 series
PA-60W-OW	60W AC/DC power adapter with 12V, 5A DC output, cord end terminals for terminal block. operating temperature : -30 to 60 °C.

Cassette Modules

CSM-PoE354	Cassette module with PCIe-PoE354at and pre-installed passive heat-spreader
CSM-PoE352	Cassette module with PCIe-PoE352at and pre-installed passive heat-spreader
CSM-USB380	Cassette module with PCIe-USB380 and pre-installed passive heat-spreader
CSM-USB340	Cassette module with PCIe-USB340 and pre-installed passive heat-spreader

Nuvo-6000 Series

Intel® 6th-Gen Core™ i7/ i5/ i3 Fanless Box-PC with Up to 5 PCIe/ PCI Expansion Slots



CE FC

Key Features

- Supports Intel® 6th-Gen Core™ i7/ i5/ i3, Pentium® and Celeron® LGA1151 CPU
- Up to five expansion slots
 - x16 PCIe, x8 PCIe and three PCI slots (Nuvo-6032)
 - x16 PCIe and x8 PCIe slots (Nuvo-6002)
- Rugged, -25 °C to 60 °C fanless operation
- 2x GbE, 4x USB3.0 and 5x COM ports
- Dual DVI display outputs
- Up to 3x 2.5" SATA accommodation and 1x mSATA socket
- Wall-mounting, (optional DIN-rail and rack-mount)
- Optional fan with automatic temperature sensing and fan control

Introduction

Nuvo-6000 series is the perfect replacement for your bulky rack-mount or wall-mount IPC systems. Leveraging Intel® 6th-Gen Skylake platform, it delivers the same computing power as traditional IPCs, but in a compact fanless form-factor.

Nuvo-6000 series supports LGA1151 socket-type CPU, you can choose from Core™ i7 to Celeron® depending on your budget/ application needs. Its 5-slot capacity offer the same level of expandability as most IPCs. The front-accessible I/O design includes 2x GbE, 4x USB3.0 and 5x COM ports, making it easier to access your Nuvo-6000 when it's placed inside a cabinet or a rack.

Neosys' proven fanless design on Nuvo-6000 translates to extraordinary reliability in rugged industrial conditions while its versatile mounting options make it fit for desktop, cabinet or a 19" rack. With similar performance, cost, compact form-factor and reliability, Nuvo-6000 series speaks for itself.

Specifications

	Nuvo-6032	Nuvo-6002	Nuvo-6032	Nuvo-6002
System Core				
Processor	Supports Intel® 6th-Gen Core™, Pentium® and Celeron® LGA1151 CPU Intel® Core™ i7-6700TE (8M Cache, 2.4/ 3.4 GHz, 35W TDP) Intel® Core™ i5-6500TE (6M Cache, 2.3/ 3.3 GHz, 35W TDP) Intel® Core™ i3-6100TE (4M Cache, 2.7 GHz, 35W TDP) Intel® Pentium® G4400TE (3M Cache, 2.4 GHz, 35W TDP) Intel® Celeron® G3900TE (2M Cache, 2.3 GHz, 35W TDP)			
Chipset	Intel® H110 Platform Controller Hub			
Graphics	Integrated Intel® HD 530/ 510 Controller			
Memory	Up to 16 GB DDR4-2133 (single SO-DIMM slot)			
I/O Interface				
Ethernet	1x Gigabit Ethernet port by Intel® I219-LM 1x Gigabit Ethernet port by Intel® I210-IT			
Video Port	2x DVI-D connectors for DVI outputs			
Serial Port	2x Software-programmable RS-232/ 422/ 485 ports 3x 3-wire RS-232 ports			
USB	4x USB3.0 ports			
Audio	1x Speaker-out			
Storage Interface				
SATA HDD	3x SATA ports for 2.5" HDD/ SSD installation	1x SATA port for 2.5" HDD/ SSD installation		
mSATA	1x full-size mSATA socket			
Expansion Bus/ Internal I/O Interface				
PCI Express	1x PCIe x16 slot @ Gen3, 16-lanes PCIe signals 1x PCIe x8 slot @ Gen2, 4-lanes PCIe signals			
PCI	3x 33MHz/ 32-bit PCI slots			
Remote Ctrl. & Status Output	1x 2x6-pin 2.0mm pin-header connector for remote on/off control and status LED output			
Power Supply				
DC Input	1x 3-pin pluggable terminal block for 8-35V DC input			
Mechanical				
Dimension	184mm(W)x225mm(D)x174mm(H)	124mm (W)x225mm(D)x174mm(H)		
Weight	3.5 kg (incl. CPU, memory and HDD)	2.8 kg (incl. CPU, memory and HDD)		
Mounting	Wall-mounting (standard), DIN-rail mounting (optional), rack-mounting (optional)			
Environmental				
Operating Temperature	-25°C ~ 60°C */**			
Storage Temperature	-40°C ~ 85°C			
Humidity	10%~90% , non-condensing			
Vibration	Operating, 5 Grms, 5-500 Hz, 3 Axes (w/ SSD, according to IEC60068-2-64)			
Shock	Operating, 50 Grms, Half-sine 11 ms Duration (w/ SSD, according to IEC60068-2-27)			
EMC	CE/FCC Class A, according to EN 55022, EN 55024 & EN 55032			

* The 100% CPU loading is applied using Passmark® BurnInTest 8.0. For detail testing criteria, please contact Neosys Technology
** For sub-zero operating temperature, a wide temperature HDD drive or Solid State Disk (SSD) is required.

Appearance

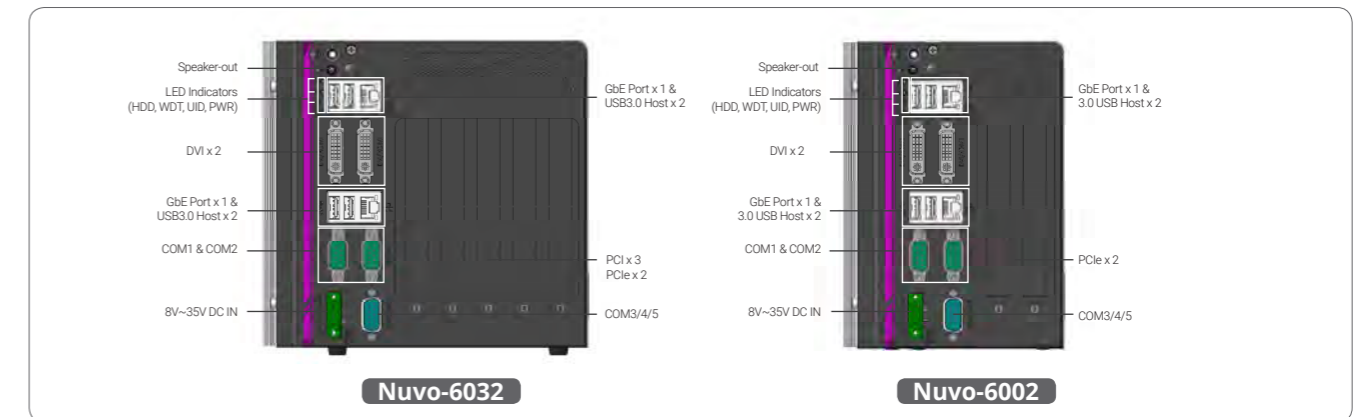

Dimensions

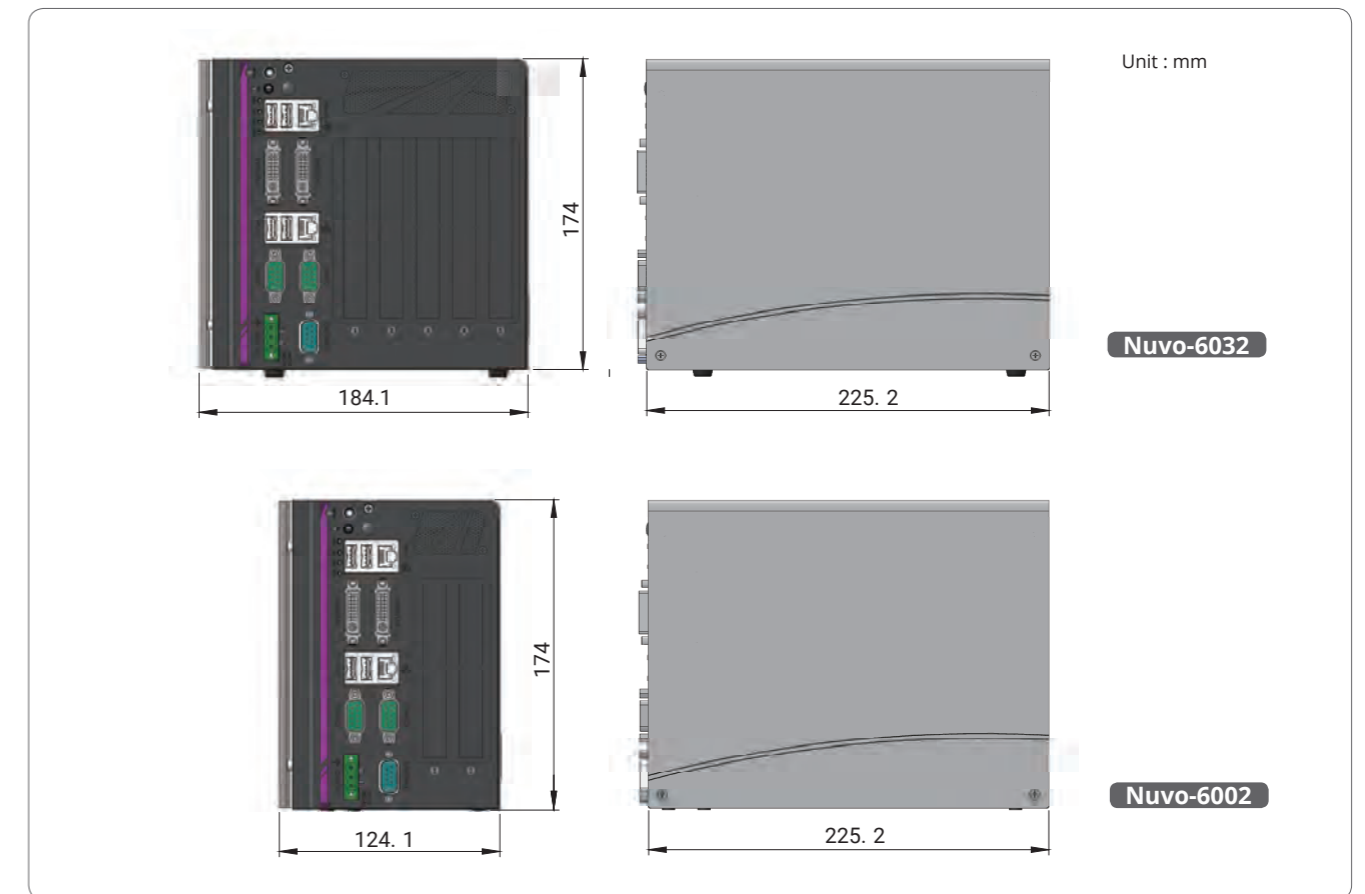

Ordering Information

Model No.	Product Description
Nuvo-6032	Intel® 6th-Gen Core™ i fanless Box-PC with 1x PCIe x16 slot, 1x PCIe x8 (@ x4 signals) slot and 3x PCI slots
Nuvo-6002	Intel® 6th-Gen Core™ i fanless Box-PC with 1x PCIe x16 slot and 1x PCIe x8 (@ x4 signals) slot

Optional Accessories

Rackmount-6	Rack mounting assembly for Nuvo-6000 series
DINRAIL-E	DIN-rail mounting assembly for Nuvo-6000 series
Fan-80	Fan assembly for Nuvo-6000 series, 80x80x15 mm
PA-120W-OW	120W AC/DC power adapter 20V/6A; 18AWG/120cm; cord end terminals for terminal block, operating temperature : -30 to 70 °C.
PA-160W-OW	160W AC/DC power adapter 20V/8A; 18AWGx4C/120cm, cord end terminals for terminal block, operating temperature : -30 to 70 °C.
C-D9-3D9-RS232-10CM	1x DB9 (female) to 3x DB9 (male), for Nuvo-6000 series, length: 10CM

Nuvo-4000 Series

Intel® 3rd-Gen Core™ i7/ i5 Fanless Box-PC with 4x PCIe/ PCI Expansion Slots



CE FC

Key Features

- Intel® 3rd-Gen i7 quad-core processor
- Four slots expansion capacity
 - x16 and x4 PCI Express slot
 - Up to four PCI slots
- 164 mm x 225 mm x 180 mm small footprint
- Rugged, -25°C to 60°C fanless operation
- DVI+DVI+VGA triple independent display outputs
- One CFast socket and two SATA ports
- Optional smart-fan and on-board isolated DIO

Introduction

Nuvo-4000 is a high-performance fanless box-pc with a small footprint. It incorporates Intel® 3rd-Gen i7/ i5 processor to offer extraordinary computing power and fanless architecture to offer reliable operation in various environments.

The 4-slot expandability makes Nuvo-4000 very versatile. Its two Gen2 PCI Express slots deliver a total of 6 GB/s bandwidth for applications demanding high-speed data transmission. A dedicated 48W power budget is supplied to the x16 PCIe slot for powering a high-watt PCIe card (e.g. a graphics card). Nuvo-4000 also has PCI slots to accommodate up to 4 PCI cards for general industrial automation, test and measurement applications.

Nuvo-4000 features one of the smallest foot-prints for a fanless box-pc with four expansion slots. It has ample I/O interfaces for communication/control purposes, and supports DVI+DVI+VGA triple independent display outputs for video/ image related applications. An optional smart fan is available for better operating reliability when high-watt cards are installed.

The combination of high performance, small footprint and versatility makes Nuvo-4000 not only an ideal application platform, but also a great replacement for traditional rack-mount or wall-mount IPC.

Specifications

System Core		Expansion Bus	
Processor	Intel® Core™ i7-3610QE (2.3/3.3 GHz, 6 MB cache) Intel® Core™ i5-3610ME (2.7/3.3 GHz, 3 MB cache) Intel® Celeron® 1020E (2.2 GHz, 2 MB cache)	PCI	2x 33MHz/32-bit 5V PCI slots (Nuvo-4022) 4x 33MHz/32-bit 5V PCI slots (Nuvo-4040)
Chipset	Intel® HM76 Platform Controller Hub	PCI Express (Nuvo-4022 only)	1x PCIe x16 slot @ 8-lanes PCIe signal with dedicated 48W power budget 1x PCIe x4 slot
Graphics	Integrated Intel® HD Graphics 4000 Controller (i7/ i5) Integrated Intel® HD Graphics Controller (Celeron™)	Power Supply	
Memory	Up to 16 GB DDR3 1333/ 1600 MHz SDRAM (two SO-DIMM slots)	DC Input	1x 3-pin pluggable terminal block for 8~25VDC DC input
Front Panel I/O Interface		Power Consumption	Intel® Core™ i7-3610QE : 66.12W (3.48A@19V) Intel® Core™ i5-3610ME : 43.13W (2.27A@19V)
Ethernet	2x Gigabit Ethernet ports by Intel® I210	Mechanical	
Video Port	1x DVI-I connector for VGA and DVI outputs, supporting 1920x1080 resolution 1x DVI-D connectors for DVI output, supporting 1920x1080 resolution (Supporting triple independent display outputs)	Dimension	164 mm (W) x 225 mm (D) x 180 mm (H)
Serial Port	2x software-programmable RS-232/ 422/ 485 (COM1 & COM2) 1x RS-232 (COM3)	Weight	4.0 kg (incl. CPU, memory and HDD)
USB	4x USB3.0 ports	Mounting	Wall-mounting (Standard) or DIN-rail mounting (optional)
Audio	1x Speaker-out	Environmental	
Internal I/O Interface		Operating Temperature	-25°C ~ 60°C, 100% CPU loading */**
USB	2x USB 2.0 ports via 10-pin box-header	Storage Temperature	-40°C ~ 85°C
Isolated DIO	Optional 8-CH isolated DI + 8-CH isolated DO	Humidity	10%~90% , non-condensing
Storage Interface		Vibration	Operating, 5 Grms, 5-500 Hz, 3 Axes (w/ SSD, according to IEC60068-2-64)
SATA HDD	2x Internal SATA ports for 2.5" HDD/ SSD installation	Shock	Operating, 50 Grms, Half-sine 11 ms Duration (w/ SSD, according to IEC60068-2-27)
CFast	1x CFast socket	EMC	CE/FCC Class A, according to EN 55022, EN 55024

* The 100% CPU loading is applied using Passmark® BurnInTest™ v7.0. For detail testing criteria, please contact Neosys Technology
** For sub-zero operating temperature, a wide temperature HDD drive or Solid State Disk (SSD) is required.

Appearance

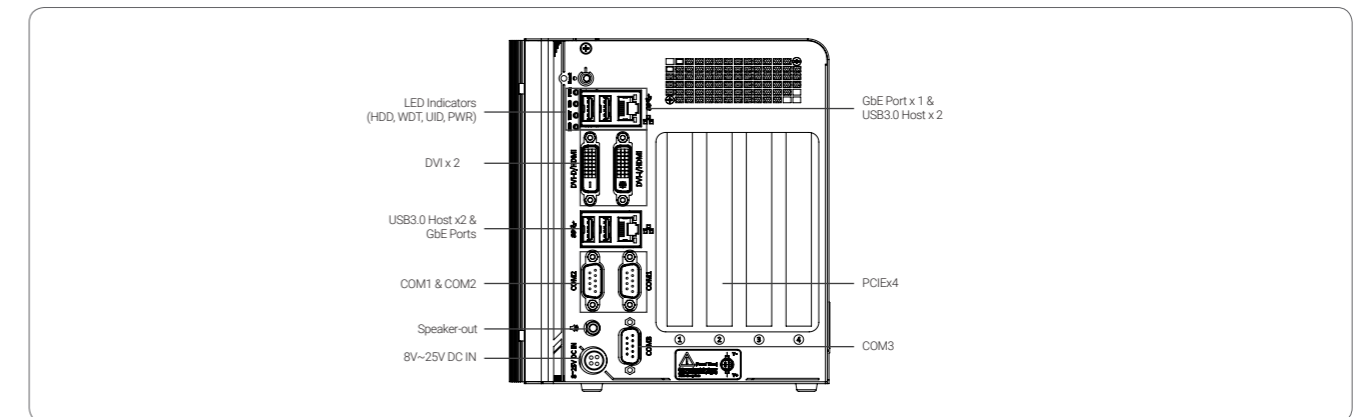

Dimensions

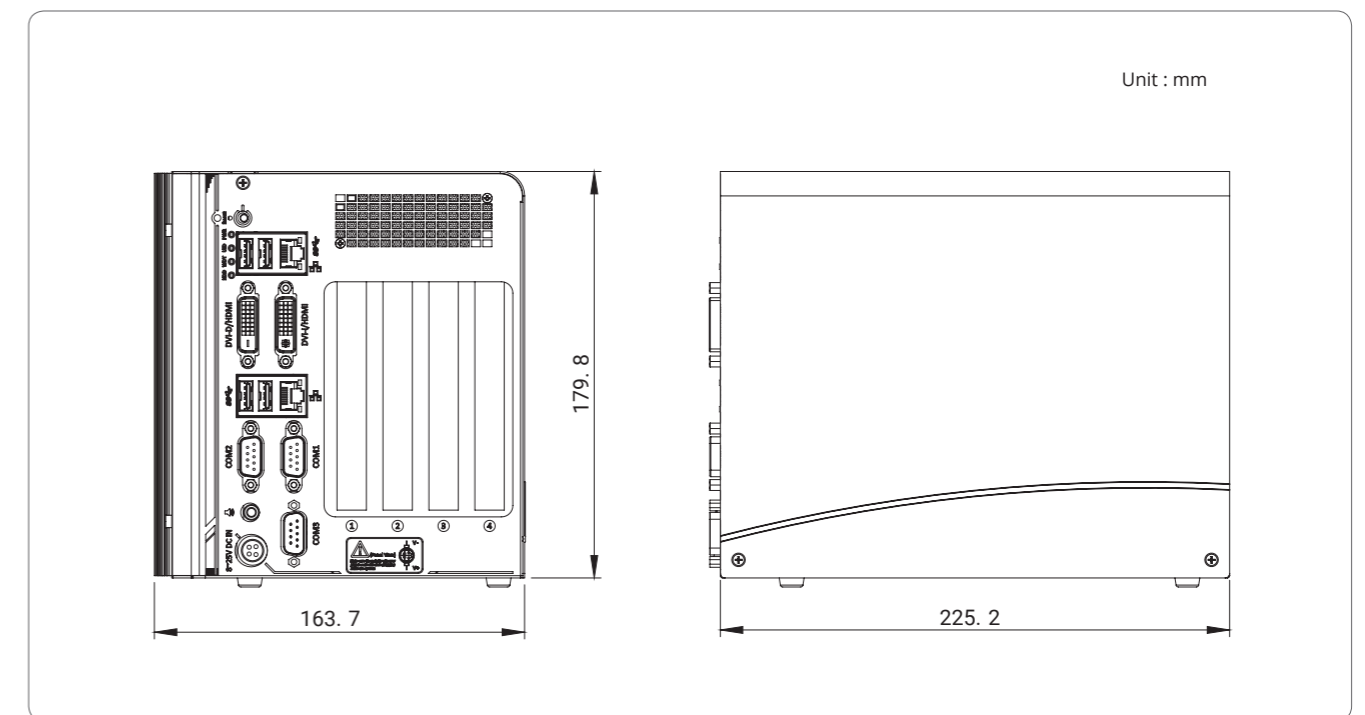

Ordering Information

Model No.	Product Description
Nuvo-4022	Intel® 3rd-Gen Core™ i fanless Box-PC with 2x PCIe and 2x PCI slots
Nuvo-4040	Intel® 3rd-Gen Core™ i fanless Box-PC with 4x PCI slots
<i>Option of isolated DIO (8 DI + 8 DO) with panel/ cable kit</i>	

Optional Accessories

DINRAIL-E	DIN-rail mounting assembly for Nuvo-4000 series
Fan-80	Fan assembly for Nuvo-4000 series, 80x80x15 mm
PA-120W	120W AC/DC power adapter 12V/8.5A (max. output 102W); 18AWG/120cm; DIN 4PIN connector, operating temperature : -30 to 70 °C.
PA-160W	160W AC/DC power adapter 20V/8A; 18AWGx4C/120cm, DIN 4PIN connector, power cord is not included.

Nuvo-2400 Series

Intel® Celeron® Bay Trail fanless Shoebox IPC with Dual Display Output, dual GbE and triple PCI/PCIe slots



CE FC

Key Features

- Intel® Celeron® Bay Trail J1900 quad-core processor
- 3x PCI slots or 1x PCIe x4 + 2x PCI slots
- Rugged, -25°C to 70°C fanless operation
- Dual independent display via DVI-I connector
- 2x SATA ports for 2.5" HDD/SSD
- 2x RS-232/ 422/ 485 and 2x RS-232
- Optional isolated 8-ch DI and 8-ch DO
- 8 to 25V DC wide-range input

Introduction

Nuvo-2400 series are fanless shoebox IPCs with 3 PCI or 2 PCI + 1 PCIe expansion slots. The expansion slots are provided for add-on cards, such as COM port cards and frame grabbers. Nuvo-2430 provides 3 PCI slots, while Nuvo-2421 provides one PCIe x4 slot with and two PCI slots (1-lane PCI Express 2.0 signal).

Nuvo-2400 series facilitate the integration of both remote on/ off switch and the system status indicators with corresponding signals reserved for buttons and LEDs outside of Nuvo-2400 so users can power on/ off Nuvo-2400 externally. Furthermore, there are optional 24V DC rated and isolated 8-channel digital inputs/ 8-channel digital outputs. This makes Nuvo-2400's DI/O compatible with many industrial sensors, indicators, coils and actuators.

Powered by Intel® Celeron® Bay Trail J1900 series quad-core processor, Nuvo-2400 series show outstanding computing power and is even more power efficient compared to its predecessors. Nuvo-2400 supports dual independent displays, dual 2.5" SATA bays and dual gigabit LAN ports with teaming and PXE. These features, together with 3 expansion slots, maximize the flexibility of Nuvo-2400 for various applications.

Specifications

System Core		Expansion Bus	
Processor	Intel® Celeron® Bay Trail J1900 quad-core processor (2.42GHz, 2M cache)	PCI	3x PCI Slot with 33MHz, 32-bit PCI signal (Nuvo-2430) 2x PCI Slot with 33MHz, 32-bit PCI signal (Nuvo-2421)
Graphics	Integrated Intel® HD graphics	PCI Express (Nuvo-2421 only)	1x PCI Express x4 slot with 1-lane Gen2 PCI Express signal
Memory	Up to 8GB DDR3L-1333MHz SDRAM (single SO-DIMM slot)	Power Supply	DC Input 8~25V DC
Front Panel I/O Interface		Mechanical	
Ethernet	2x Gigabit Ethernet by Intel® Ethernet controller I210	Dimension	139 mm (W) x 225 mm (D) x 160 mm (H)
Video Port	1x DVI-I connector for VGA and DVI dual independent display outputs	Weight	2.2 kg (incl. CPU, memory and HDD)
Serial Port	2x BIOS-configurable RS-232/ 422/ 485 (COM1 & COM2)	Mounting	Wall-mount (standard) or DIN-rail mount (optional)
USB	1x USB3.0 and 3x USB2.0	Environmental	
Audio	1x Mic-in and 1x speaker-out	Operating Temperature	-25°C ~ 70°C, 100% CPU loading */**
Internal I/O Interface		Storage Temperature	-40°C ~ 85°C
Serial Port	2x RS-232 (COM3 & COM4)	Humidity	10%~90% , non-condensing
Parallel Port	1x parallel port	Vibration	Operating, 5 Grms, 5-500 Hz, 3 Axes (w/ SSD, according to IEC60068-2-64)
Isolated DIO	Optional 8-CH DI and 8-CH DO (polling mode only)	Shock	Operating, 50 Grms, Half-sine 11 ms Duration (w/ SSD, according to IEC60068-2-27)
Remote Control & Status Output	1x 3-pin 2.0mm wafer connector for remote on/ off control 1x 2x6-pin 2.0mm pin-header connector for status output	EMC	CE/FCC Class A, according to EN 55022, EN 55024
Storage Interface			
SATA HDD	2x internal SATA ports for 2.5" HDD/ SSD installation		

* The 100% CPU loading is applied using Passmark® BurnInTest™ v7.0. For detail testing criteria, please contact Neosys Technology
** For sub-zero operating temperature, a wide temperature HDD drive or Solid State Disk (SSD) is required.

Appearance

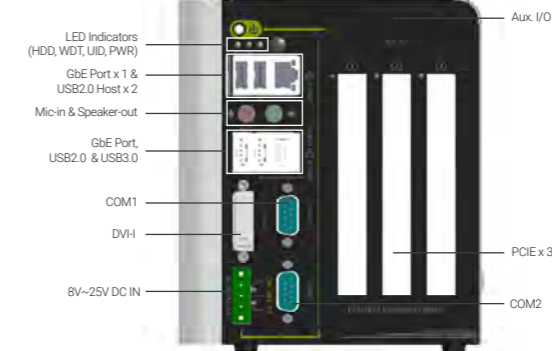

Dimensions

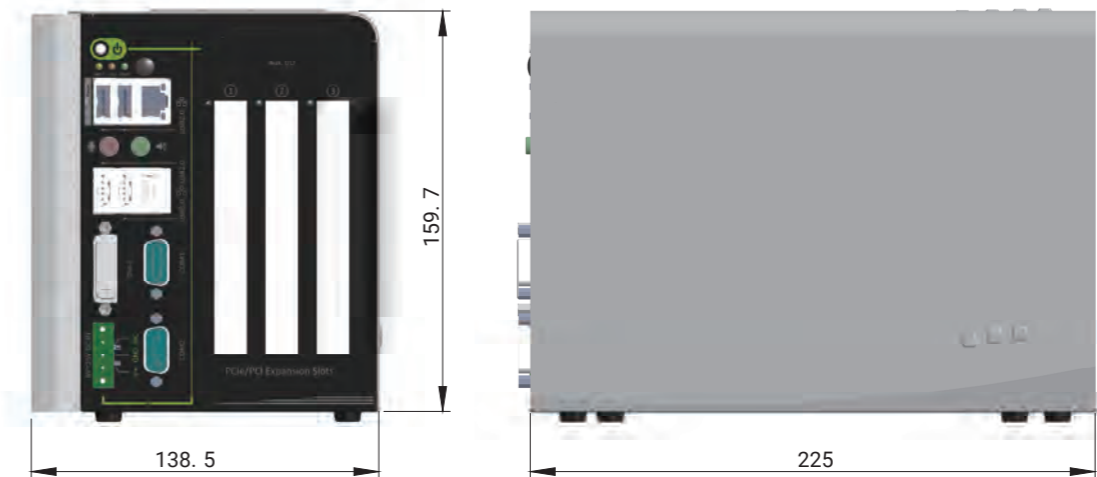

Unit : mm

Ordering Information

Model No.	Product Description
Nuvo-2430	Intel® Bay Trail Celeron® J1900 fanless shoe-box IPC with dual display, dual GbE and 3x PCI slots
Nuvo-2421	Intel® Bay Trail Celeron® J1900 fanless shoe-box IPC with dual display, dual GbE, 2x PCI slots and one PCIe x4 slot
<i>Option of isolated DIO (8 DI + 8 DO)</i>	

Optional Accessories

Panel/ cable kit for 2x COM ports	
Panel/ cable kit for 1x COM + 1x LPT ports	
Fan-80	Fan assembly for Nuvo-2400 series, 80x80x15 mm
DINRAIL-E	DIN-rail mounting assembly for Nuvo-2400 series
PA-60W-OW	60W AC/DC power adapter with 12V, 5A DC output, cord end terminals for terminal block. operating temperature : -30 to 60 °C

PB-2500J Series

Industrial-Grade Intelligent Ultracapacitor-based Power Backup Module



Key Features

- Ultracapacitor-based, -25 to 65°C wide temperature operation
- 2500 watt-second energy capacity
- Up to 10 years lifespan and 500,000 charging/ discharging cycles
- Patented CAP energy management technology*
 - Maximizes back-up time in an event of unforeseen power outage
 - Monitors energy consumed and estimates the time required for system shutdown
- User-configurable operating parameters
 - Auto/ manual shutdown control
 - High/ low voltage protection
 - UltraCAP energy/ lifespan configuration

*R.O.C Patent No. 1598820

Introduction

Neosys' PB-2500J series is an innovative power backup solution for demanding industrial applications. Utilizing ultracapacitor technology, it features -25°C to 65°C operating temperature range and extremely high durability. Compared to traditional battery-based UPS systems, PB-2500J series can sustain superb reliability in extreme temperature environments and eliminates the drawback of battery performance degradation over time.

PB-2500J series is composed of eight 100F ultracapacitors to provide 2500 watt-second stored energy to sustain your computer during power outage and depending on your system's power consumption, it could be from seconds to minutes. But what makes PB-2500J novel is its patented CAP energy management technology, an on-board processor that constantly monitors power consumption and evolves with the system. During a power outage, it maximizes the system operation time by estimating the perfect time to initiate system shutdown to prevent data loss.

PB-2500J series is available in two form-factors; PB-2500J-PCIe is a plug-and-play PCIe card specifically designed for Neosys Nuvo-6000 (except Nuvo-6108GC/IGN) while PB-2500J-CSM is designed for Nuvo-5000E/P and Nuvo-7000E/P series.

When it comes to industrial embedded controllers, stability and data loss prevention during power outages are just as important. Neosys' PB-2500J series aims to do the latter by redefining reliability and taking it to another level. With PB-2500J series, unexpected power loss and unstable power lines are a thing in the past!

Specifications

	PB-2500J-PCIe	PB-2500J-CSM
Ultracapacitor configuration	8x 100F, 3.0V ultracapacitors	
Capacity	2500 watt-second	
Expected lifespan	>10 years @ 25°C with 2500 w-s capacity* 76,000 hours @ 35°C with 2500 w-s capacity* 34,000 hours @ 45°C with 2500 w-s capacity* 15,000 hours @ 55°C with 2500 w-s capacity* 7,200 hours @ 65°C with 2500 w-s capacity* Expected lifespan is 2.2x when configured as 2100 watt-second energy capacity, or 4.8x when configured as 1750 watt-second energy capacity.	
Cycle life	500,000 charging/ discharging cycles*	
Communication interface	3-wire RS-232	
Dimension	Half-length PCIe card 167 mm (W) x 111 mm (H)	-
Mounting	N/A	DIN-rail mounting or wall-mounting
Operating Temperature	-25°C ~ 65°C	
Storage Temperature	-40 °C ~ 70°C	
EMC	CE/FCC Class A, according to EN 55022 & EN 55024	

*Once the rated lifespan or cycle life has been reached, the capacity of ultracapacitor may decrease up to 30% and ESR may increase up to 100% from initial values.

Ordering Information

Model No.	Product Description
PB-2500J-PCIe	Intelligent ultracapacitor-based power backup PCIe card with 2500 w-s energy capacity
PB-2500J-CSM5	Intelligent ultracapacitor-based power backup Cassette module with 2500 w-s energy capacity, for Nuvo-5000 series
PB-2500J-CSM7	Intelligent ultracapacitor-based power backup Cassette module with 2500 w-s energy capacity, for Nuvo-7000 series

*Note: NOT compatible with Nuvo-6108GC and Nuvo-6108GC-IGN

Ultracapacitor-based Power Backup Solution

Battery vs. Ultracapacitor

For decades, battery has been the preferred form of energy storage as it has high energy density (10~100 Wh/kg). However, limited by operating temperature (typically 0°C~40°C) and cycle life (2 years or 500 charge-discharge cycles), battery is neither rugged nor durable enough for industrial applications. Ultracapacitor, also called electric double-layer capacitor (EDLC) or supercapacitor, is an emerging category of capacitor offering 10~100 times more energy density than electrolytic capacitor (1~10 Wh/kg). In addition to its impressive energy density, ultracapacitor also has a wide operating temperature range (-40°C~85°C) and long operating life (10 years or 500,000 charge-discharge cycles). These two traits help make a reliable industrial power backup solution come true.

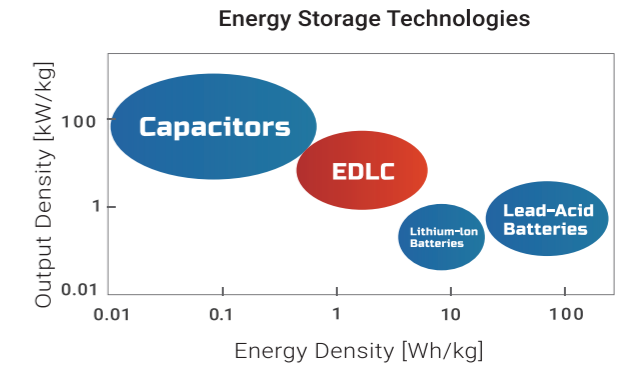

Neosys' Patented CAP Energy Management Technology

To design and create a reliable ultracapacitor-based power backup system requires fundamental techniques such as charge/ discharge control, active load balance and DC/ DC regulation. But the real challenge is how to get the most out of the capacitor energy while ensuring the system shuts down safely during the blackout.

At Neosys Technology, we have patented an architecture (R.O.C. Patent No. 1598820) that incorporates a microprocessor along with ultracapacitors and charge/ discharge controller. The proprietary firmware embedded in the MCU not only monitors energy level continuously, it also automatically initiates soft-shutdown to prevent data loss/ corruption.

The patented architecture provides sophisticated features such as real-time energy monitoring, high/low voltage protection and auto/ manual shutdown control. Users can also extend the lifespan of ultracapacitors up to 4.8x via the parameter configuration utility.

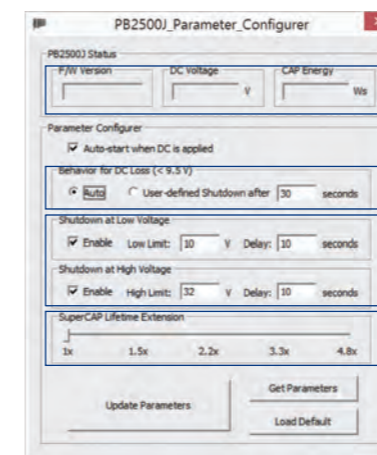
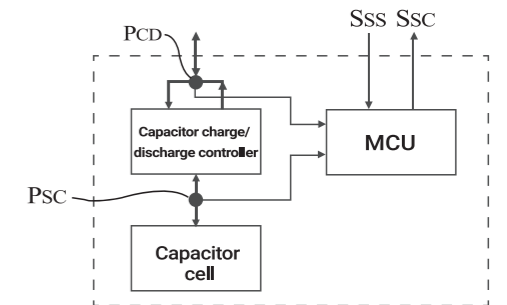

- Real-time input voltage & CAP energy monitoring
- Auto or user-configurable shutdown control
- High/ low voltage protection. Shutdown the system when input voltage exceeds/ below thresholds
- Extend superCAP lifespan by reducing energy capacity

Ultracapacitor-based Power Backup Solution vs. UPS

Combining ultracapacitors and our patented architecture, Neosys introduces a revolutionary ultracapacitor-based power backup solution for industrial applications. Compared to battery-based UPS, it has wider operating temperature, extended operating life, adequate backup time to secure your embedded controller against unforeseen power outages.

	PB-2500J	Off-line UPS	Interactive UPS	On-line UPS
Energy storage technology	Ultracapacitor	Battery	Battery	Battery
Backup time	1 ~ 3 mins	> 30 mins	> 30 mins	> 30 mins
Operating temperature	-25°C ~ 65°C	0°C ~ 40°C	0°C ~ 40°C	0°C ~ 40°C
Lifespan	> 10 yrs @ 25°C	2 yrs @ 25°C	2 yrs @ 25°C	2 yrs @ 25°C
Regulated power output	Yes	No	No	Yes
Shutdown control	Automatic, plug and play	Via RS-232 and software	Via RS-232 and software	Via RS-232 and software

POC-300 Series

Intel® Apollo Lake Pentium® N4200 and Atom™ E3950 Ultra-Compact DIN-rail Controller with GbE, PoE and USB3.0



CE FC

Key Features

- Intel® Apollo Lake Pentium® N4200 and Atom™ E3950 quad-core processor
- Fanless, rugged and wide temperature operation (-25 °C to 70 °C)
- One GbE port and two Gigabit PoE+ ports
- Two USB3.0 and two USB2.0 ports
- DVI + VGA dual display outputs
- Front-accessible I/O
- DIN-rail mounting design
- MeziO™ interface compatible

Introduction

Experience the giant leap in performance of Intel® Apollo Lake Pentium® and Atom™ platform! POC-300 series features the latest Pentium® N4200 and Atom™ x7-E3950 quad-core processors, which offers up to 1.5 times of CPU performance and 3 times the GPU performance improvement compared to previous generation Atom™ E3845 CPU.

POC-300 series have an ingenious mechanical design that combines DIN-rail mounting chassis with front-accessible I/O in one ultra-compact enclosure. They have rich computer-like I/Os such as GbE, USB3.0/ 2.0, COM ports and mSATA storage, in a compact footprint that measures just 5.6 x 15 x 11 cm. IEEE 802.3at PoE+ function is also available on 2 of the 3 GbE ports to power cameras for machine vision or surveillance applications. POC-300 series features Neosys' MeziO™ interface for easy function expansion via versatile MeziO™ modules.

With Neosys' proven fanless design heritage, the POC-300 series thrive in harsh environments. Featuring rich I/Os, advanced CPU and compact size, POC-300 series are compelling fanless controllers beneficial for various industrial applications.

Specifications

	POC-300	POC-310	POC-320	POC-330
System Core				
Processor	Intel® Atom™ E3950 1.6/ 2.0 GHz quad-core processor		Intel® Pentium® N4200 1.1/ 2.5 GHz quad-core processor	
Graphics	Integrated Intel® HD Graphics 505			
Memory	Up to 8GB DDR3L-1866 (single SO-DIMM slot)			
Panel I/O Interface				
Ethernet	3x Gigabit Ethernet ports by Intel® I210 GbE controller			
PoE	IEEE 802.3at PoE+ on port #2 and #3	-	IEEE 802.3at PoE+ on port #2 and #3	-
Video Port	VGA and DVI dual display outputs via DVI-I connector			
USB	2x USB3.0 ports and 2x USB2.0 ports			
Serial Port	1x Software-programmable RS-232/ 422/ 485 ports (COM1) 3x 3-wire RS-232 ports (COM2/ 3/ 4) or 1x RS-422/ 485 port (COM2)			
Audio	1x Mic-in and 1x speaker-out			
Internal I/O Interface				
Mini-PCIe	1x full-size mini PCI Express slot with USIM socket			
Expandable I/O	1x MeziO™ expansion interface for Neosys MeziO™ modules			
Storage Interface				
mSATA	1x half-size mSATA port			
Power Supply				
DC Input	1x 3-pin pluggable terminal block for 8-35V DC input			
Mechanical				
Dimension	56 mm (W) x 108 mm (H) x 153 mm (D)			
Weight	0.96 kg (incl. CPU, memory and HDD)			
Mounting	DIN-rail mount (standard) or wall-mount (optional)			

	POC-300	POC-310	POC-320	POC-330
Environmental				
Operating Temperature	-25°C ~ 70°C with SSD, 100% CPU loading */** -10°C ~ 50°C with HDD, 100% CPU loading */**			
Storage Temperature	-40°C ~ 85°C**			
Humidity	10%~90% , non-condensing			
Vibration	Operating, 5 Grms, 5-500 Hz, 3 Axes (w/ SSD, according to IEC60068-2-64)			
Shock	Operating, 50 Grms, Half-sine 11 ms Duration (w/ SSD, according to IEC60068-2-27)			
EMC	CE/FCC Class A, according to EN 55022, EN 55024 & EN 55032			

* The 100% CPU/GPU loading for high temperature test is applied using Passmark® BurnInTest™ v8.0.
For detail testing criteria, please contact Neosys Technology

** For sub-zero operating temperature, a wide temperature HDD drive or Solid State Disk (SSD) is required.



▲ POC-300 with MeziO™ - R11 and 2.5" HDD

Appearance

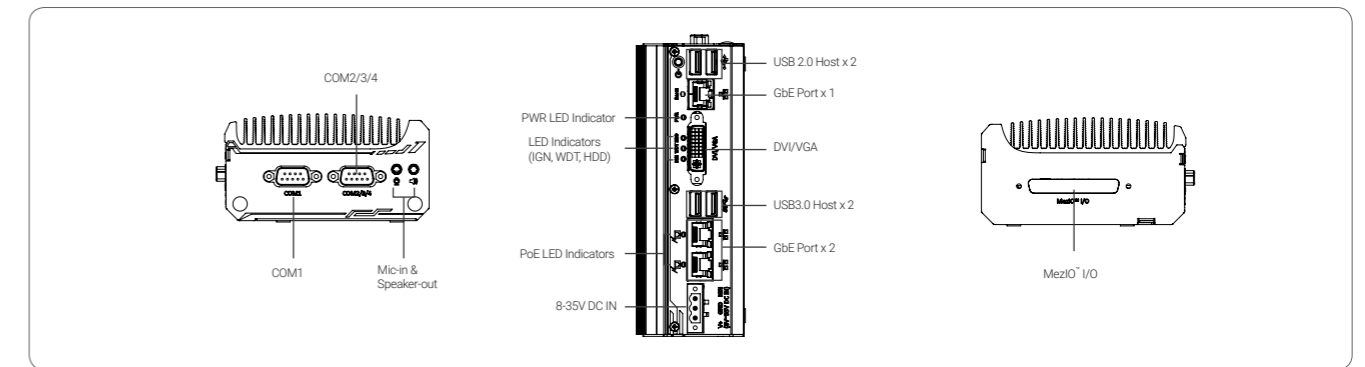

Dimensions

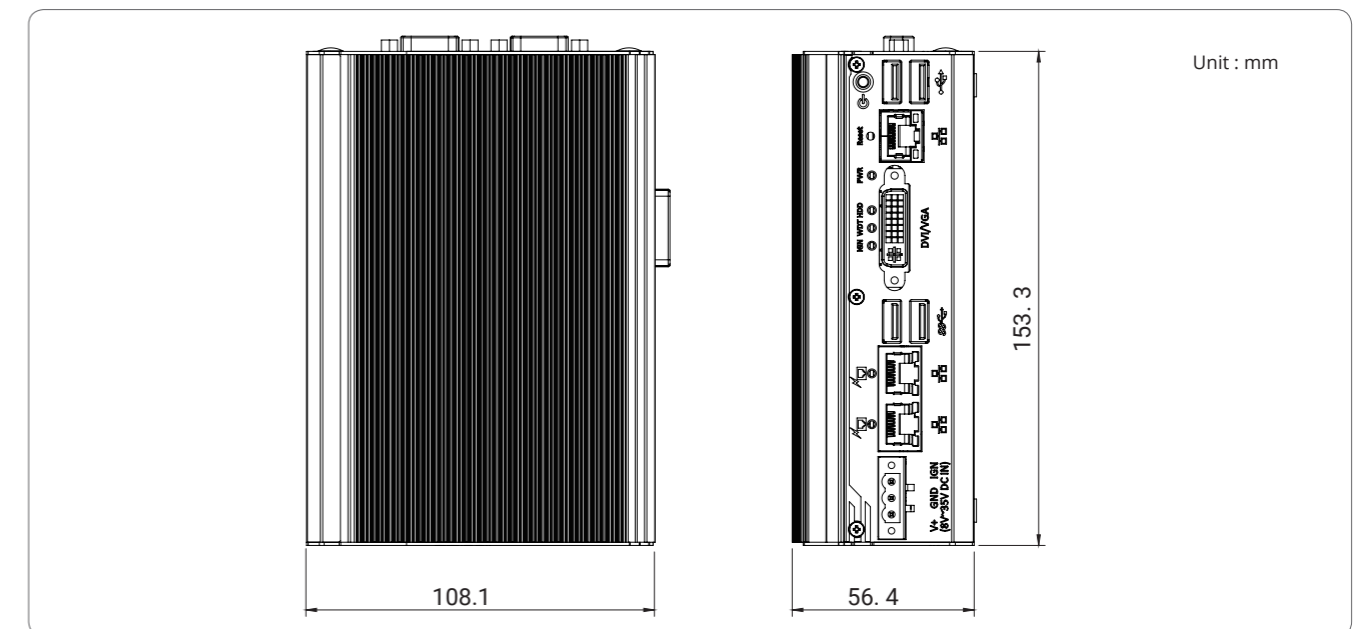

Ordering Information

Model No.	Product Description
POC-300	Intel® Apollo Lake Atom™ E3950 ultra-compact DIN-rail controller with 1xGbE, 2x PoE+ and 2x USB3.0
POC-310	Intel® Apollo Lake Atom™ E3950 ultra-compact DIN-rail Controller with 3xGbE and 2x USB3.0
POC-320	Intel® Apollo Lake Pentium® N4200 ultra-compact DIN-rail controller with 1xGbE, 2x PoE+ and 2x USB3.0
POC-330	Intel® Apollo Lake Pentium® N4200 ultra-compact DIN-rail controller with 3xGbE and 2x USB3.0

Ordering Model Matrix

Pre-Installed Controller	MeziO-R11	MeziO-R12
POC-300	POC-301	POC-302
POC-310	POC-311	POC-312
POC-320	POC-321	POC-322
POC-330	POC-331	POC-332

Optional Accessories

PA-60W-OW	60W AC/DC power adapter with 12V, 5A DC output, cord end terminals for terminal block. operating temperature : -30 to 60 °C
WM-300V	Wall mounting assembly for POC-300 series, vertical type
WM-300H	Wall mounting assembly for POC-300 series, horizontal type
64GB mSATA mini SSD with pre-installed Windows 10 IoT English version*	
128GB mSATA mini SSD with pre-installed Windows 10 IoT English version*	
C-D9-3D9-RS232-10CM	1x DB9 (Female) to 3x DB9 (Male), length: 10CM

MeziO™ Modules

MeziO™ -C180	MeziO™ module with 4x RS-232/ 422/ 485 ports and 4x RS-232 ports
MeziO™ -C181	MeziO™ module with 4x RS-232/ 422/ 485 ports and 4x RS-422/ 485 ports
MeziO™ -D220	MeziO™ module with 8-CH isolated digital input and 8-CH isolated digital output
MeziO™ -D230	MeziO™ module with 16-CH isolated digital input and 16-CH isolated digital output
MeziO™ -V20	MeziO™ module with ignition power control function and 1x mini-PCIe socket for in-vehicle usage
MeziO™ -U4	MeziO™ module with 4x USB
MeziO™ -R11	MeziO™ module with SATA port for 2.5" HDD/ SSD
MeziO™ -R12	MeziO™ module with SATA port for 2.5" HDD/ SSD, 4-CH isolated DI and 4-CH isolated

* For Windows 10 IoT with other language packages, MOQ is required. Please contact Neosys for further information

POC-200 Series

Ultra-Compact Atom™ Bay Trail-I Fanless Embedded Controller with PoE and USB3.0



Key Features

- Ultra-compact 15 cm x 10 cm (6" x 4") footprint
- Intel® Atom™ E3845 1.91GHz quad-core processor
- Rugged, -25°C to 70°C fanless operation
- Two 802.3at (25.5W) Gigabit PoE+ ports
- Three USB3.0 ports and one USB2.0 port
- One 2.5" SATA HDD/ SSD accommodation
- Up to two RS-232/ 422/ 485 ports and two RS-232 ports

CE FC

*R.O.C Patent No. M492598

Introduction

POC-200 is Neosys' breakthrough ultra-compact controller series. Inheriting the concept of favorable POC-100, POC-200 series features greater computing power and more versatile functions in its 3.5" HDD footprint.

The new Intel® Atom™ Bay Trail processor offers dramatic arithmetic and graphics performance improvement. With Atom™ E3845 quad-core processor, POC-200 can deliver more than 200% performance over previous D525/ D2550 platforms. It also features comprehensive I/O interfaces to make use of the advanced computing power. Two Gigabit Ethernet and three USB3.0 ports are integrated so you can connect GigE/ USB3.0 cameras for vision applications. Its IEEE 802.3at PoE+ option is capable of supplying 25.5W each port to power IP cameras for surveillance applications. POC-200 also features up to four COM ports and digital I/O for general-purpose industrial applications.

Its compact size is another attractive feature of POC-200. The 15 x 10 cm (6"x4") footprint allows installation of POC-200 in confined spaces. While its -25°C to 70°C wide temperature operating capability eliminates the restriction for deployment environment. Neosys provides derivative models with different CPU and I/O configurations so you can always find a POC-200 that is ideal for your application.

Specifications

	POC-200	POC-210	POC-212	POC-222		POC-200	POC-210	POC-212	POC-222
System Core					Storage Interface				
Processor	Intel® Atom™ E3845 1.91 GHz quad-core processor			Intel® Atom™ E3825 1.33 GHz dual-core processor	SATA	1x internal SATA port for 2.5" HDD/ SSD		1x internal SATA port with easy-swap HDD tray for 2.5" HDD/ SSD	
Graphics	Integrated Intel® HD Graphics				Power Supply				
Memory	Up to 8GB DDR3L-1333 (single SO-DIMM slot)			DDR3L-1067, up to 4GB	DC Input 1x 2-pin pluggable terminal block for Built-in 8-35 VDC DC input				
Panel I/O Interface					Mechanical				
Ethernet	2x Gigabit Ethernet ports by Intel® I210 GbE controller				Dimension (W x D x H)	105mm x 149mm x 58 mm		105mm x 149mm x 53mm	
PoE	IEEE 802.3at PoE+(25.5W each GbE port)		-		Weight	1.05 kg (incl. CPU, memory and HDD)			
Video Port	1x DVI-I connector for both analog RGB and DVI outputs				Mounting	Wall-mount (standard); DIN-rail mount (optional)			
Serial Port	2x RS-232/ 422/ 485 (COM1 & COM3) 2x RS-232 (COM2 & COM4)		1x RS-232/ 422/ 485 (COM1) 1x RS-232 (COM2)		Environmental				
USB	3x USB3.0 ports and 1x USB2.0 port				Operating Temp.	-25°C ~ 70°C with SSD, 100% CPU loading **/*** -10°C ~ 50°C with HDD, 100% CPU loading **/***			
Audio	1x Speaker-out				Storage Temp.	-40°C ~ 85°C			
DIO	4-CH isolated DI 4-CH isolated DO	8-CH 5V TTL GPIO (Standard) 4-CH isolated DI + 4-CH isolated DO (Optional)			Humidity	10%~90%, non-condensing			
Panel I/O Interface					Vibration	Operating, 5 Grms, 5-500 Hz, 3 Axes (w/ SSD, according to IEC60068-2-64)			
Mini-PCle	1x mini PCI Express slot with USIM socket				Shock	Operating, 50 Grms, Half-sine 11 ms Duration (w/ SSD, according to IEC60068-2-27)			
					EMC	CE/FCC Class A, according to EN 55022, EN 55024 & EN 55032			

* 100% CPU loading is applied using Intel® Thermal Analysis Tool. For detail testing criteria, please contact Neosys Technology.
** For sub-zero operating temperature, a wide temperature mSATA SSD module is required.

Appearance

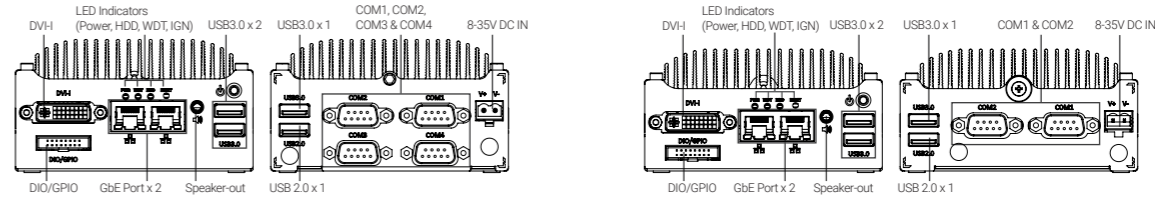

POC-200/POC-210

POC-212/POC-222

Dimensions

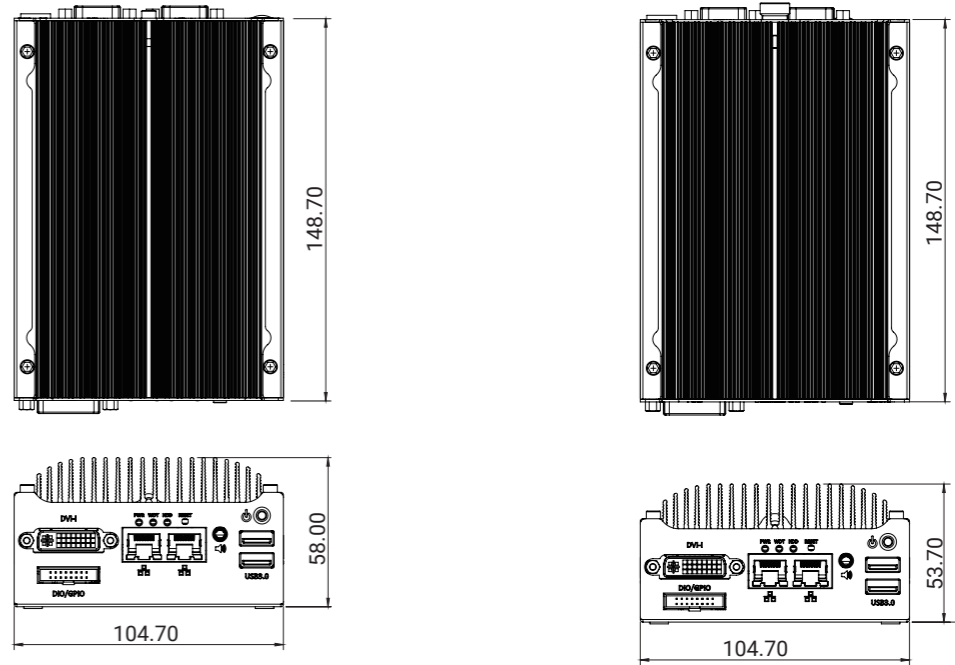

Unit : mm

POC-200/POC-210

POC-212/POC-222

Ordering Information

Model No.	Product Description
POC-200	Intel® Atom™ E3845 ultra-compact controller with 2x 802.3at PoE ports, 3x USB3.0 ports and 4x COM ports
POC-210	Intel® Atom™ E3845 ultra-compact controller with 2x GbE ports, 3x USB3.0 ports and 4x COM ports
POC-212	Intel® Atom™ E3845 ultra-compact controller with 2x GbE ports, 3x USB3.0 ports and 2x COM ports
POC-222	Intel® Atom™ E3825 ultra-compact controller with 2x GbE ports, 3x USB3.0 ports and 2x COM ports

Optional Accessories

DINRAIL-P	DIN-rail mounting assembly for POC- 200 series
PA-60W-OW	60W AC/DC power adapter with 12V, 5A DC output, cord end terminals for terminal block. operating temperature : -30 to 60 °C

POC-120 Series

Ultra-compact Atom™ Bay Trail-I Fanless General-Purpose Embedded Controller



Key Features

- Low-profile, ultra-compact 15 cm x 10 cm x 3.4 cm footprint
- Intel® Atom™ E3826 1.46GHz dual-core processor
- Rugged, -25°C to 70°C fanless operation
- Two GigE ports and three USB2.0 ports
- One RS-232/ 422/ 485 port and one RS-232 port
- I/O expansion interface for ODM projects
- MezIO™ interface for easy function expansion

CE FC

Introduction

Introducing Neosys' ultra-compact POC family! POC-120 is a low-cost, entry-level embedded controller in ultra-compact dimensions. With a height of 3.4 cm, the low-profile chassis is ideal for installation into confined spaces.

POC-120 utilizes Intel® Atom™ E3826 dual-core processor and it provides general I/Os, such as GigE ports, COM ports and USB3.0/ USB2.0 ports. For embedded applications, instead using traditional HDD, POC-120 supports mSATA SSD to ensure reliable disk access in harsh industrial environments. POC-120MZ also features Neosys' MezIO™ interface for I/O expansion. By customizing a mezzanine board, you can have versatile I/O functions and turn POC-120MZ from an ultra-compact controller into a tailor-made ultra-compact embedded system for your application needs.

Specifications

System Core		Power Supply	
Processor	Intel® Atom™ E3826 1.46 GHz dual-core processor	DC Input	Built-in 8-35V DC input
Graphics	Integrated Intel® HD Graphics	Input Connector	2-pin spring-clamp terminal block for DC input
Memory	Up to 8GB DDR3L-1333 (single SO-DIMM slot)	Mechanical	
I/O Interface		Dimension	105mm (W) x 149 mm (D) x 34mm (H) (POC-120) 105mm (W) x 149 mm (D) x 46mm (H) (POC-120MZ)
Ethernet	2x Gigabit Ethernet ports by Intel® i210 GbE controller	Weight	0.9 kg
Video Port	1x VGA connector for both analog RGB output, supporting 2560x1600 resolution	Mounting	Wall-mounting (standard) or DIN-rail mounting (optional)
Serial Port	1x RS-232/ 422/ 485 (COM1) 1x RS-232 (COM2)	Environmental	
USB	1x USB3.0 port and 2x USB2.0 ports	Operating Temperature	-25°C ~ 70°C with SSD, 100% CPU loading */**
Audio	1x Speaker-out	Storage Temperature	-40°C ~ 85°C
Storage Interface		Humidity	10%~90% , non-condensing
mSATA	1x full-size mSATA socket	Vibration	Operating, 5 Grms, 5-500 Hz, 3 Axes (w/ SSD, according to IEC60068-2-64)
Expansion Bus		Shock	Operating, 50 Grms, Half-sine 11 ms Duration (w/ SSD, according to IEC60068-2-27)
Expandable I/O (POC-120MZ only)	1x MezIO™ expansion port for Neosys' MezIO™ modules	EMC	CE/ FCC Class A, according to EN 55022 & EN 55024

* 100% CPU loading is applied using Intel® Thermal Analysis Tool. For detail testing criteria, please contact Neosys Technology.
** For sub-zero operating temperature, a wide temperature mSATA SSD module is required.

Appearance

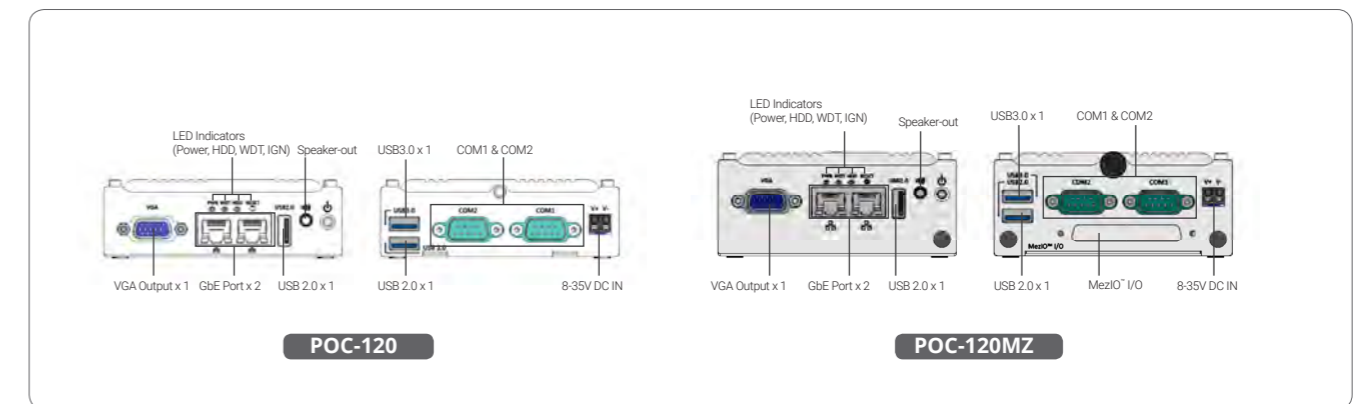

Dimensions

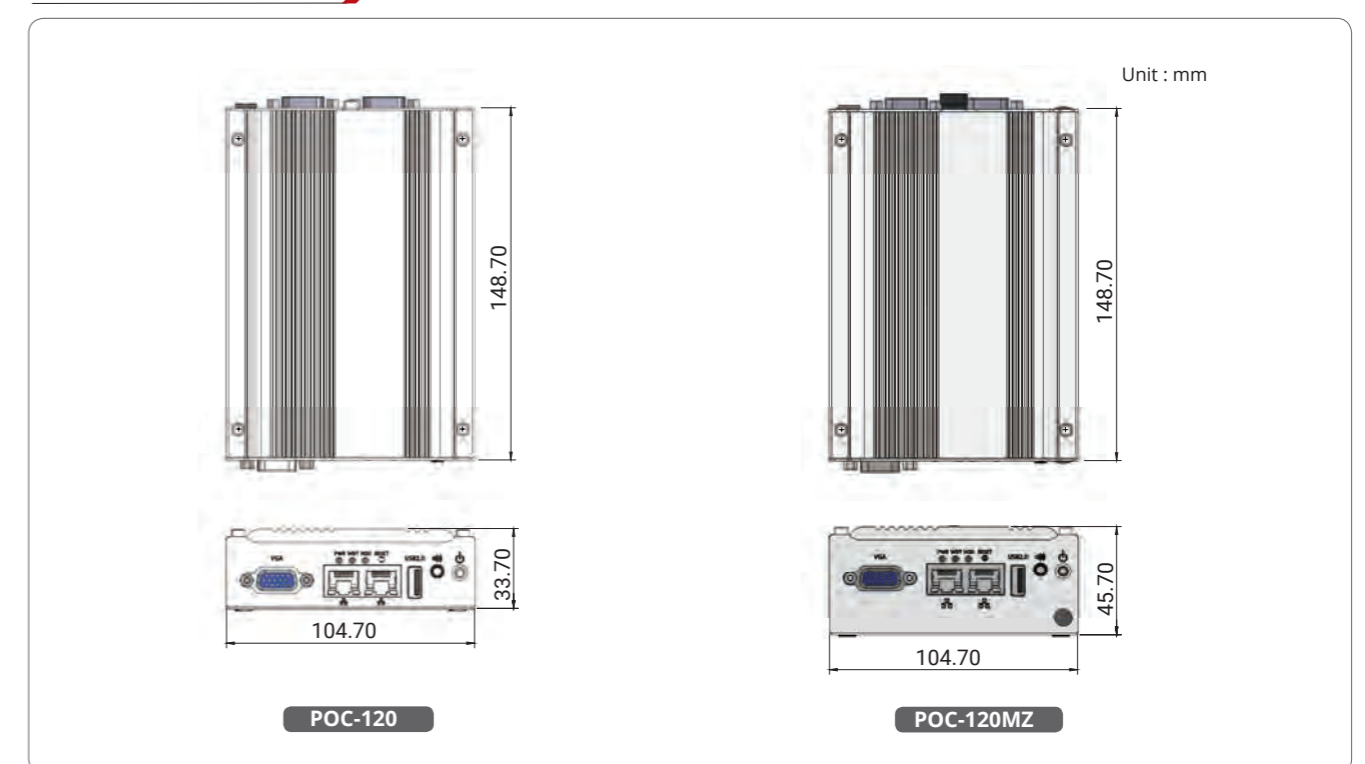

Ordering Information

Model No.	Product Description
POC-120	Intel® Atom™ E3826 ultra-compact controller with 2x GbE ports, 3x USB and 2x COM ports
POC-120MZ	Intel® Atom™ E3826 ultra-compact controller with 2x GbE ports, 3x USB, 2x COM ports and MezIO™ accommodation

Optional Accessories

DINRAIL-P	DIN-rail mounting assembly for POC-120 series
PA-60W-OW	60W AC/DC power adapter with 12V, 5A DC output, cord end terminals for terminal block. operating temperature : -30 to 60 °C

MezIO™ Modules

MezIO™-C180	MezIO™ module with 4x RS-232/ 422/ 485 ports and 4x RS-232 ports
MezIO™-C181	MezIO™ module with 4x RS-232/ 422/ 485 ports and 4x RS-422/485 ports
MezIO™-D220	MezIO™ module with 8-CH isolated digital input and 8-CH isolated digital output
MezIO™-D230	MezIO™ module with 16-CH isolated digital input and 16-CH isolated digital output
MezIO™-R10	MezIO™ module with 2.5" HDD/ SSD accommodation and 1x mini-PCIe socket

ETHY-100-2008(S)

Ethernet I/O Expansion Module with 8 Digital Inputs and 8 Digital outputs



CE FC

Key Features

- Rich I/O combination and decentralization
- Daisy chain for both data and power
- Direct wiring and removable terminal block
- I/O status indicators and user define MMI
- Built-in designated mechanism to configure a responsive automated system for local

Introduction

ETHY-100-2008/ 2008S is a system expansion I/O module featuring 8 digital inputs, 8 digital outputs and configurable man-machine interface (MMI). It can be daisy-chained and supports Power over Ethernet (PoE) for data transfer. You can use PoE to connect to 3rd party devices such as IP cameras or other PoE devices to expand your system. The PoE and terminal block are also useful to add/ remove the device in awkward or remote locations. In addition, being a powerful external I/O module, Ethy-100-2008/ 2008s provides friendly application programming interface (API) and designated mechanism which allow users to configure a responsive automated system with low latency and high in performance. ETHY-100-2008/ 2008S is the best automation solution.

Specifications

	ETHY-100-2008S	ETHY-100-2008		ETHY-100-2008S	ETHY-100-2008
General					
Module Status Indicator	4 LEDs (Power/ Error/ Link/ Run)		OS Support		
I/O Status Indicator	1 LED for each channel		Windows	Windows 7 32/64-bit	
User Define MMI	3-digit 7 segment display & 2 buttons		Power		
I/O Connectors	4 removable 3.81 mm connectors		PoE PD	IEEE 802.3at PoE+ PD	
Communication Interface	2 Ethernet ports		PoE PSE	IEEE 802.3at PoE+ PSE	-
Reset Button	1 reset button to recover factory settings		DC Input	24VDC ±10%	
Digital Input					
Channels	8 channels		Power Consumption	3W	
Input Type	Sinking/Sourcing, Channel-to-Channel Isolated		Mechanical		
Input Voltage	Logic Level 0: 0 to 5V Logic Level 1: 11 to 30V		Dimensions	125.4mm (W) x 101.8mm (H) x 25.9mm (D) (including connectors)	
Isolation Voltage	2500 VDC		Weight	450g	
Digital Output					
Channels	8 channels		Environment		
Output Type	Sink		Operating Temperature	-25°C ~ 70 °C	
Rated Output Voltage	24VDC		Storage Temperature	-40°C ~ 85 °C	
Rated Output Current	100mA per channel		Humidity	10~90%, non-condensing	
Max. Output Current	500mA		EMC	CE/FCC Class A (to be certified)	
Isolation Voltage	2500 VDC				

Appearance

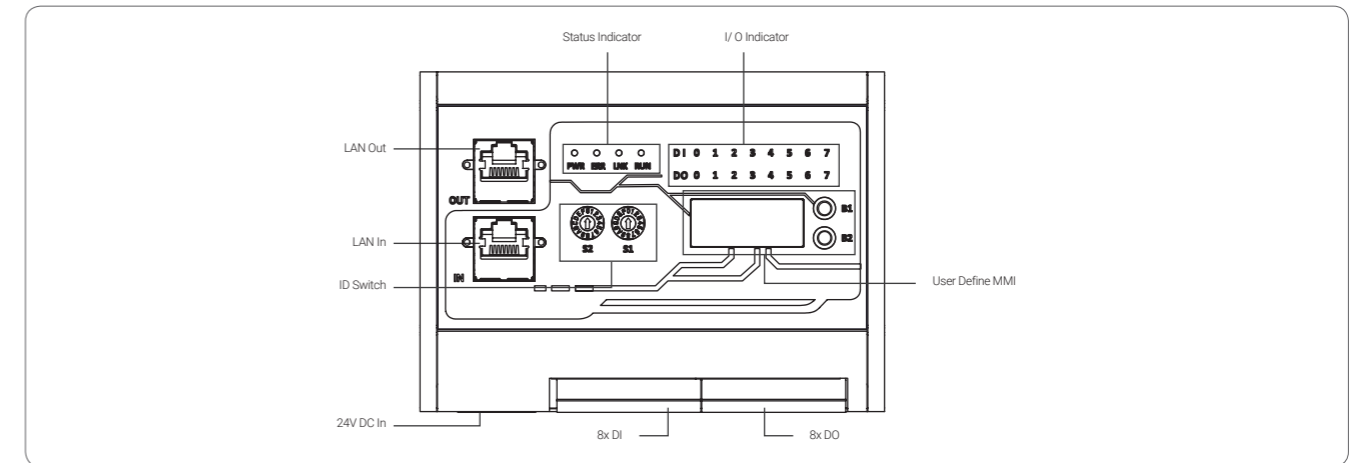

Dimensions

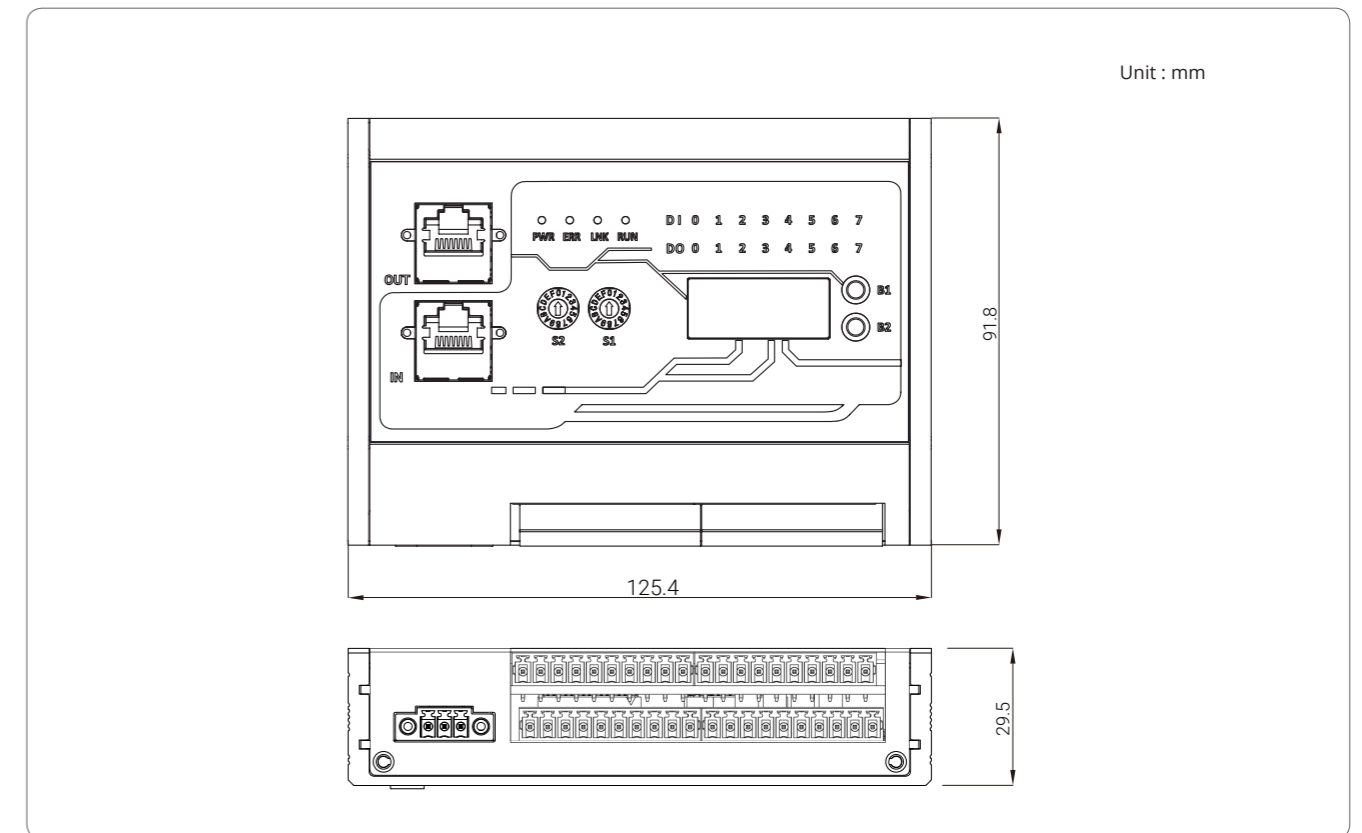

Ordering Information

Model No.	Product Description
ETHY-100-2008S	Ethernet I/O Expansion Module with 8 Digital Inputs and 8 Digital Outputs with PSE
ETHY-100-2008	Ethernet I/O Expansion Module with 8 Digital Inputs and 8 Digital Outputs

IGT-20 / IGT-21

Industrial Grade ARM-based Smart Wireless IoT Gateway Device with ARM Cortex A8, Dual T-Flash (microSD), and Pre-installed Debian



CE FCC

Key Features

- Industrial grade ARM-based system with pre-installed Debian
- Compact size, designed for wireless gateway application
- Operating temperature from -25°C to 70°C
- 8 to 25V wide-range DC input
- Rich local I/O, such as USIM slot, USB, 10/100M LAN, and RS-232/ 422/ 485

Introduction

IGT-20 is an industrial grade ARM-based gateway. Unlike System on Module (SoM) that's commonly provided as a barebone component, IGT-20 is based on AM3352 from Texas Instrument's Sitara AM335x family and will be shipped as a ready system pre-installed with Debian. The industrial nature of IGT-20 means it is in compliance with common industrial certifications such as CE/FCC, shock and vibration. Another distinction IGT-20 has over SoM is that it accepts a wider range of power inputs ranging from 8 to 25 VDC (SoM usually accepts 5 VDC).

IGT-20 has I/Os that are applicable to a range of industrial grade sensors. It features one USB2.0, one 10/100M LAN, two configurable COM ports (RS-232/422/485) and an optional CAN bus port (IGT-21 only). In addition to the ports mentioned, there are 4 built-in isolated digital input channels that accept discrete signals from various sensors or buttons/ switches. There are also four built-in isolated digital output channels to control actuators and indicators.

Communication wise, IGT-20 has a mini PCIe slot and a USIM holder allowing it to transmit acquired data and system status via 3G, 4G or WiFi (mini PCIe WiFi module). There is an opening on top of IGT-20 for users to mount the SMA connector of the wireless module. In terms of storage, IGT-20 has dual microSDHC slots, one internal and one external. This design allows users to separate system/ user data and can expedite in OS deployment for mass production. As a gateway, users can take advantage of six programmable status LED indicators and two control buttons to operate IGT-20 without using a keyboard/ mouse.

Specifications

System Core	
Processor	TI Sitara AM3352 1GHz processor
Memory	1GB DDR3L SDRAM
DC Input Range	8~25V DC
Front-panel I/O Interface	
Ethernet	1x 10/100M Ethernet
SD Card	1x external T-flash socket support SDHC
SIM Card	1x external SIM socket
USB	1x USB2.0
Isolated DIO	4-CH isolated DI and 4-CH isolated DO
Console	1x 3-wire RS-232
User LEDs	6x user programmable LEDs
User Buttons	2x user programmable buttons
CAN	1x CAN bus 2.0 A/B (IGT-21 only)
Top I/O Interface	
DC-in	1x DC-input connector
Power Button	1x power button
Reset Button	1x reset button
Serial Port	2x software configurable RS-232/ 422/ 485
Antenna Hole	1x antenna hole for WiFi and 3G/LTE
Internal I/O Interface	
mPCIe	1x Full size mPCIe with USB2.0 only
SD Card	1x internal T-flash socket support SDHC
Software	
Operating System	Debian 8 pre-installed
Mechanical	
Dimension	41mm(W) x 77mm(D) x 104mm(H)
Weight	0.4 Kg
Mounting	DIN-rail mounting
Environmental	
Operating Temperature	-25°C ~ 70°C *
Vibration	5Grms
Shock	50Grms
EMC	CE/FCC Class A, according to EN 55032

* For sub-zero operating temperature, a wide temperature microSD module is required.

Appearance

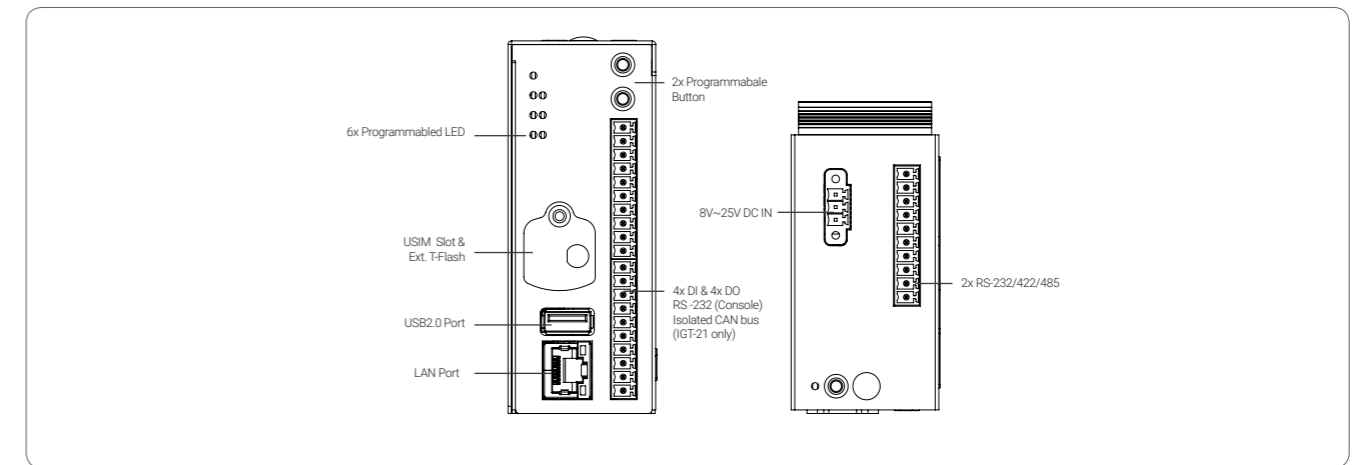

Dimensions

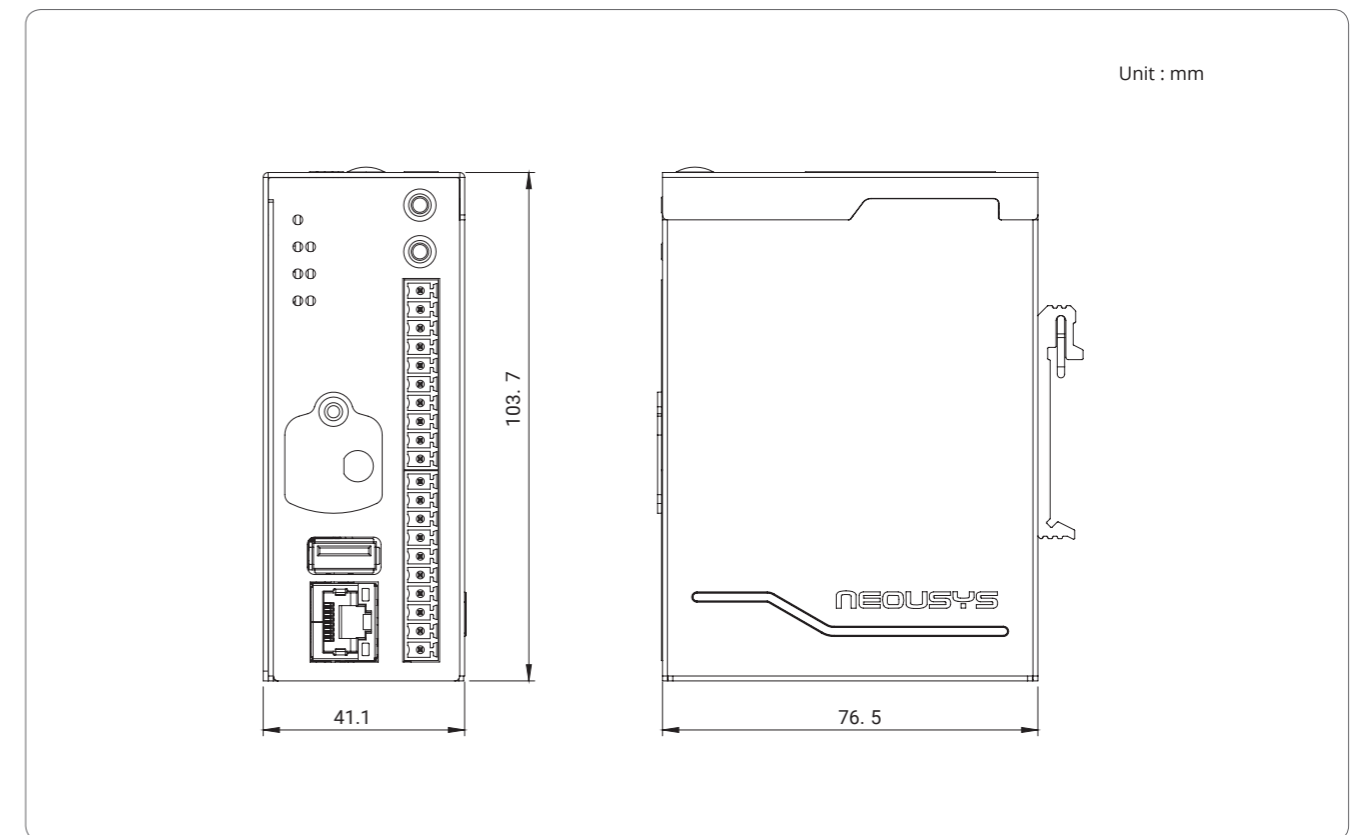

Ordering Information

Model No.	Product Description
IGT-20	Industrial grade ARM-based IoT gateway
IGT-21	Industrial grade ARM-based IoT gateway with CAN bus

Nuvis-5306RT Series

Intel® 6th-Gen Core™ i7/ i5 Vision Controller with Vision-Specific I/O, Real-time Control and GPU-Computing



CE FC

Key Features

- Intel® 6th-Gen Core™ i7/ i5 65W/ 35W CPU, up to 32 GB DDR4
- Integrated vision-specific I/O
 - 4-CH CC/ CV lighting controller
 - 4-CH camera trigger outputs
 - 1-CH quadrature encoder input
 - 8-CH isolated DI and 8-CH isolated DO
- Patented MCU-based, real-time I/O control by DTIO* V2 and NuMCU
- Built-in camera interfaces
 - 4-CH IEEE 802.3at Gigabit PoE+ ports
 - 4-CH USB3.0 ports
- Supports NVIDIA® GPU with up to 75W TDP GPU-accelerated machine vision
- Patented graphic card ventilation*

*R.O.C Patent No. I526834/ M534371 / M456527

Introduction

As one of the most powerful vision controller ever created, Nuvis-5306RT integrates every single function you need for machine vision applications in a compact footprint, including exceptional computing power, built-in camera interfaces and real-time vision-specific I/O control.

To ensure high quality images, a machine vision (MV) system requires accurate interaction between lighting, camera, actuator and sensor devices. Nuvis-5306RT integrates LED lighting controller, camera trigger, encoder input, PWM output and digital I/O, to connect and control all vision devices. All vision-specific I/Os are managed by Neosys' patented MCU-based architecture and DTIO V2/ NuMCU firmware to guarantee microsecond-scale real-time I/O control.

Computing power is another crucial requirement for a vision system. In addition to the remarkable performance brought by its Intel® 6th-Gen Core™ i7/ i5 CPU, Nuvis-5306RT can also accommodate 75W NVIDIA® GPU to leverage CPU-accelerated vision library or deep-learning vision software. Combining built-in PoE+ and USB3.0 interfaces and the expandability for CameraLink and CoaXPress, Nuvis-5306RT is the ideal platform for demanding MV applications.

Specifications

System Core	
Processor	Supports Intel® 6th-Gen Core™ LGA1151 CPU - Intel® Core™ i7-6700 (8M Cache, 3.4/ 4.0 GHz, 65W TDP) - Intel® Core™ i5-6500 (6M Cache, 3.2/ 3.6 GHz, 35W TDP) - Intel® Core™ i7-6700TE (8M Cache, 2.4/ 3.4 GHz, 35W TDP) - Intel® Core™ i5-6500TE (6M Cache, 2.3/ 3.3 GHz, 35W TDP)
Chipset	Intel® Q170 Platform Controller Hub
Graphics	Integrated Intel® HD Graphics 530
Memory	Up to 32 GB DDR4-2133 SDRAM by two SO-DIMM sockets
AMT	Supports AMT 11.0
TPM	Supports TPM 2.0
Vision-Specific I/O Interface	
LED Lighting Controller	4-CH LED lighting controller output, supporting - Constant current mode (up to 2A per channel, 100 kHz dimming control) - Constant voltage mode (24V DC, 100 kHz dimming control)
Camera Trigger	4-CH camera trigger output (12V DC output)
Encoder Input	1-CH quadrature encoder input (A/ B/ Z)
Isolated Digital Output	4-CH isolated high-speed DO (<2 us transient time, for strobe/PWM) 4-CH isolated high-current DO (up to 500 mA rated current)
Isolated Digital Input	8-CH isolated high-speed digital input (<2 us transient time)
Real-time I/O Control	Patented MCU-based real-time I/O control with DTIO V2 or NuMCU firmware
General I/O Interface	
Ethernet port	6x Gigabit Ethernet ports by Intel® 1x I219 and 5x I210
PoE+	IEEE 802.3at PoE+ PSE on GigE Port 3 ~ Port 6, 80 W total power budget
USB3.0	4x USB3.0 ports via native xHCI controller, 1000 MB/s total bandwidth
USB 2.0	4x USB2.0 ports
Video Port	1x stacked VGA + DVI-D connector 2x DisplayPort connectors, supporting 4K2K resolution
Serial Port	2x software-programmable RS-232/422/485 port (COM1 & COM3) 1x RS-232 port (COM2)
Audio	1x Mic-in and 1x Speaker-out
Storage Interface	
SATA HDD	2x internal SATA port for 2.5" HDD/SSD installation, supporting RAID 0/1
mSATA	1x full-size mSATA port (mux with mini-PCIe)
Expansion Bus	
PCI/PCI Express	1x PCIe x16 slot @ Gen3, 8-lanes PCIe signals in Cassette, supporting - 75W NVIDIA® GPU card - COTS CameraLink and CoaXPress camera interface card
Mini PCI-E	1x internal mini PCI Express socket with front-accessible SIM socket 1x internal mini PCI Express socket with internal SIM socket (mux with mSATA)
Power Supply	
DC Input	1x 3-pin pluggable terminal block for 8~35V DC input
Remote Ctrl. & Status Output	1x 10-pin (2x5) wafer connector for remote on/off control and status LED output
Mechanical	
Dimension	240 mm (W) x 225 mm (D) x 111 mm (H)
Weight	4.5 kg (incl. CPU, memory and HDD)
Mounting	Wall-mount by mounting bracket
Environmental	
Operating Temperature	with i7-6700TE, i5-6500TE (35W TDP) -25°C ~ 60°C ** with i7-6700, i5-6500 (65W TDP) -25°C ~ 60°C **/** (configured as 35W CPU mode) -25°C ~ 50°C **/** (configured as 65W CPU mode)
Storage Temperature	-40°C ~ 85°C**
Humidity	10%~90%, non-condensing
Vibration	Operating, 5 Grms, 5-500 Hz, 3 Axes (w/ SSD, according to IEC60068-2-64)
Shock	Operating, 50 Grms, Half-sine 11 ms duration (w/ SSD, according to IEC60068-2-27)
EMC	CE/ FCC Class A, according to EN 55022, EN55032 & EN 55024

* For i7-6700 running at 65W mode, the high operating temperature shall be limited to 50°C and thermal throttling may occur when sustained full-loading applied. Users can configure CPU power in BIOS to obtain higher operating temperature.

** For sub-zero operating temperature, a wide temperature HDD drive or Solid State Disk (SSD) is required.

Appearance

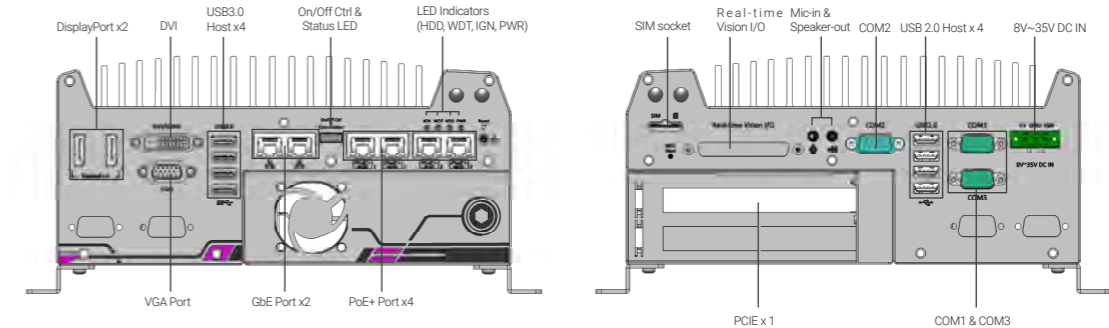

Dimensions

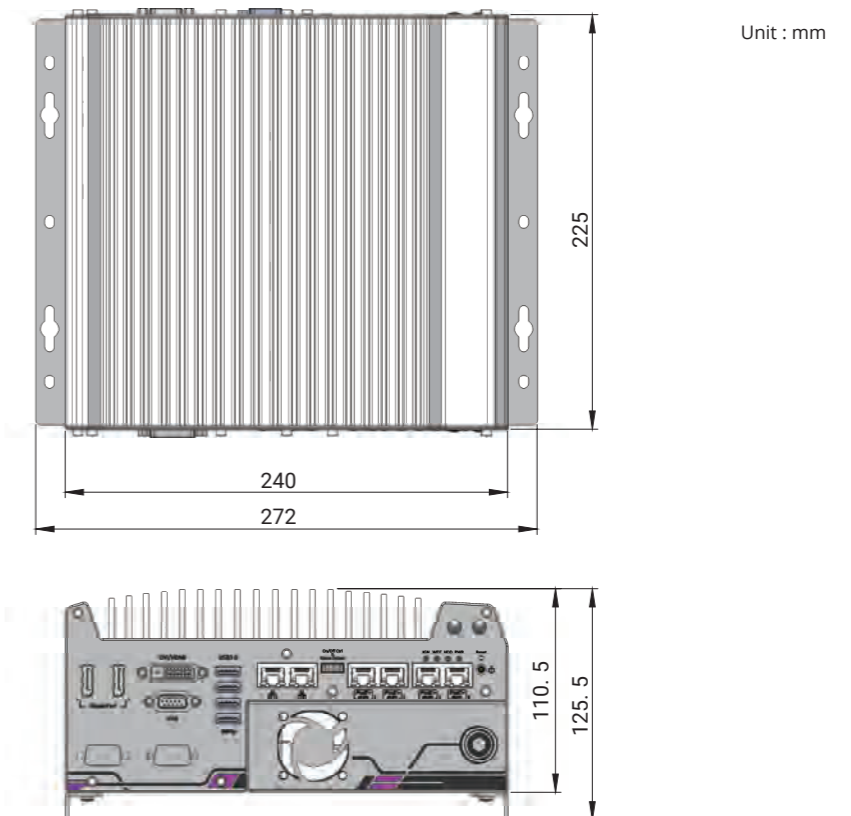

Ordering Information

Model No.	Product Description
Nuvis-5306RT-DTIO	Intel® 6th-Gen Core™ i vision controller with vision-specific I/O, real-time control by DTIO V2 and GPU-computing
Nuvis-5306RT-NuMCU	Intel® 6th-Gen Core™ i vision controller with vision-specific I/O, real-time control by NuMCU and GPU-computing

Optional Accessories

PA-160W-OW	160W AC/DC power adapter 20V/8A; 18AWGx4C/120cm, cord end terminals for terminal block, operating temperature : -30 to 70 °C.
Fan-40	Fan assembly for 2-slot Cassette, 40x40x10 mm

Nuvis-3304af Series

Intel® 3rd-Gen Core™ i7/ i5 Fanless Vision System with 4x GigE PoE and Deterministic Trigger I/O



CE FC

Key Features

- Intel® 3rd-Gen i7 quad-core processor
- Integrated camera interfaces
 - 4x 802.3af Gigabit PoE ports via Intel® I210
 - 4x USB3.0 ports
- Patented Deterministic Trigger I/O* technology for accurate trigger/ strobe control
- Patented Cassette* design for PCIe/ PCI add-on card expansion
- Per-port PoE power on/ off control
- Rugged, -25°C to 70°C fanless operation

*R.O.C Patent No. I526834 / M456527

Introduction

Nuvis-3304af is specifically designed for machine vision applications. Inheriting Neosys' proven fanless architecture and Power-over-Ethernet technology, Nuvis-3304af combines superb computing performance, integrated camera interfaces and great reliability in a compact chassis.

As accurate trigger/ strobe control is crucial for vision applications, Neosys developed a new technology "Deterministic Trigger I/O or DTIO" for Nuvis-3304af. Unlike legacy isolated DIO, this patented DTIO technology (R.O.C Patent No. I526834) allows users to program a deterministic timing correlation between input and output signals at a resolution of 25 microseconds. With DTIO, your vision system can have extremely precise control for proximity sensor input, strobe output and camera trigger.

Camera connectivity is another key feature for vision systems. In addition to integrated PoE and USB3.0 ports, Nuvis-3304af also features Neosys' patented Cassette (R.O.C Patent No. M456527) design for PCIe/ PCI expansion. By installing a dedicated interface card, Nuvis-3304af can work with analog, 1394, Camera Link or CoaXPress camera. Alternatively, you can integrate a motion control card to fulfill an all-in-one inspection system. Combining the quad-core CPU performance, PoE/ USB3.0 camera interface, innovative DTIO and Cassette technology, Nuvis-3304af is the perfect platform for your vision application.

Specifications

System Core		Expansion Bus	
Processor	Intel® Core™ i7-3610QE (2.3/ 3.3 GHz, 6 MB cache) Intel® Core™ i5-3610ME (2.7/ 3.3 GHz, 3 MB cache)	Mini PCI-E	1x internal mini PCI Express socket with USIM socket 1x internal mini PCI Express socket
Chipset	Intel® HM76 Platform Controller Hub	PCIe	1x PCIe x16 slot @ 8-lanes PCIe signals in Cassette (Nuvis-3304af-E)
Graphics	Integrated Intel® HD Graphics 4000 Controller	PCI	1x PCI slot in Cassette (Nuvis-3304af-P)
Memory	Up to 16 GB DDR3 1333/ 1600 MHz SDRAM (two SO-DIMM slots)	Power Supply & Ignition Control	
I/O Interface		DC Input	1x 4-pin power connector for 8-25V DC input (for AC adapter) 1x 3-pin pluggable terminal block for 8-25V DC input (for direct DC wiring)
PoE	4x Gigabit IEEE 802.3af (15.4W) PoE ports by Intel® I210	Remote Ctrl. & Status Output	1x 10-pin (2x5) wafer connector for remote on/ off control and status LED output
Ethernet	1x Gigabit Ethernet port by Intel® I210	Power Consumption	With i7-3610QE : 72.96W (3.84A@19V) With i5-3610ME : 48.83W (2.57A@19V)
Video Port	1x DB-15 connector for analog RGB, supporting 2048x1536 resolution 2x DVI-D connectors for DVI outputs, supporting 1920x1080 resolution (Supporting dual independent display outputs)	Mechanical	
Serial Port	2x software-programmable RS-232/ 422/ 485 (COM1 & COM2)	Dimension	240 mm (W) x 225 mm (D) x 90 mm (H)
USB	4x USB3.0 ports and 4x USB2.0 ports	Weight	4.4 Kg (incl. CPU, memory and HDD)
KB/MS	1x 6-pin mini-DIN connector for PS/2 keyboard/ mouse	Mounting	Wall-mounting (Standard) or DIN-rail mounting (optional)
Audio	1x Mic-in and 1x Speaker-out	Environmental	
Deterministic Trigger I/O		Operating Temperature	-25°C ~ 70°C */** (with i5-3610ME) -25°C ~ 60°C */** (with i7-3610QE)
Digital Input	6x Gigabit Ethernet ports by Intel® i5 I219 and 5x I210	Storage Temperature	-40°C ~ 85°C**
Digital Output	8x isolated digital output channels	Humidity	10%~90%, non-condensing
Operating Mode	DTIO with 25 microseconds resolution, Polling I/O with change-of-state interrupt	Vibration	Operating, 5 Grms, 5-500 Hz, 3 Axes (w/ SSD, according to IEC60068-2-64)
Storage Interface		Shock	Operating, 50 Grms, Half-sine 11 ms Duration (w/ SSD, according to IEC60068-2-27)
SATA HDD	1x Internal SATA port for 2.5" HDD/SSD installation	EMC	CE/FCC Class A, according to EN 55022 & EN 55024
CFast	1x CFast socket	* 100% CPU loading is applied using Intel® Thermal Analysis Tool. For detail testing criteria, please contact Neosys Technology. **For sub-zero operating temperature, a wide temperature HDD drive or Solid State Disk (SSD) is required.	

* 100% CPU loading is applied using Intel® Thermal Analysis Tool. For detail testing criteria, please contact Neosys Technology.
**For sub-zero operating temperature, a wide temperature HDD drive or Solid State Disk (SSD) is required.

Appearance

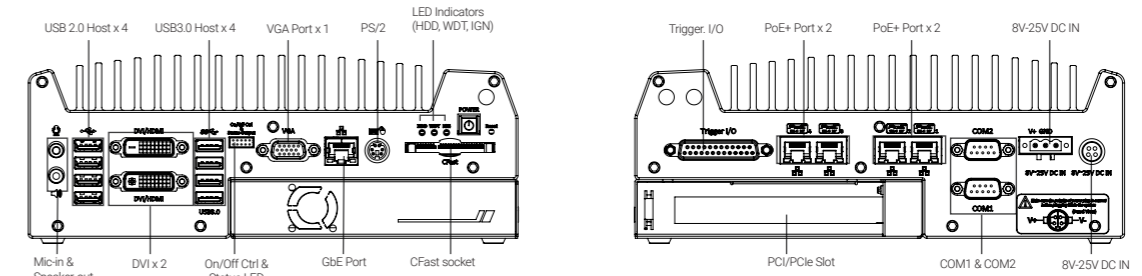

Dimensions

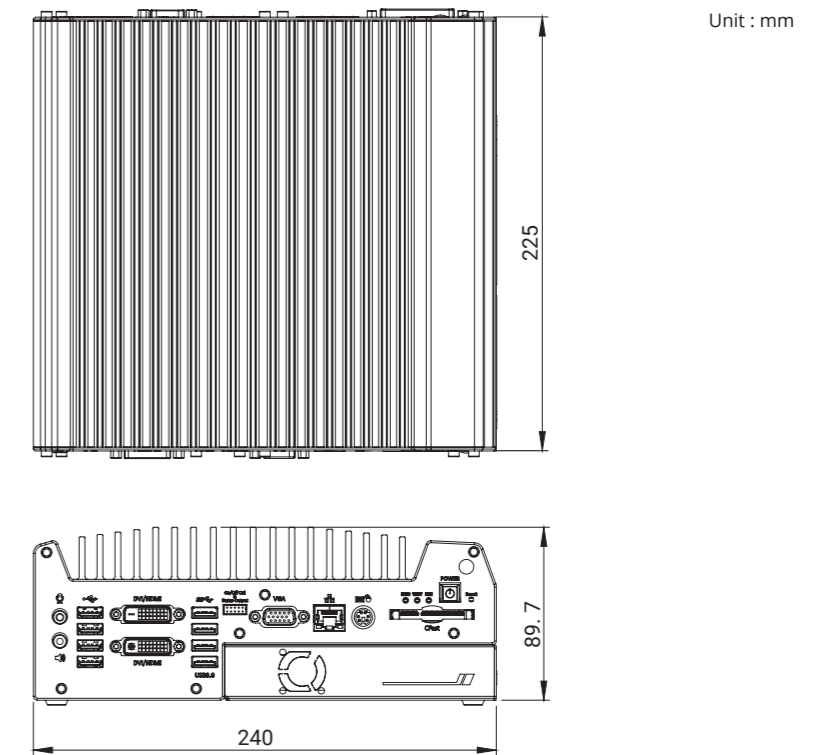

Ordering Information

Model No.	Product Description
Nuvis-3304af-E	Intel® 3rd-Gen Core™ i fanless machine vision controller with 5x GigE PoE ports, DTIO and x16 PCI Express Cassette (@ x8 signals)
Nuvis-3304af-P	Intel® 3rd-Gen Core™ i fanless machine vision controller with 5x GigE PoE ports, DTIO and PCI Cassette

Optional Accessories

DINRAIL-O	DIN-rail mounting assembly for Nuvis-3304af series
PA-160W-OW	160W AC/DC power adapter 20V/8A; 18AWGx4C/120cm, cord end terminals for terminal block. operating temperature : -30 to 70 °C.
Fan-25	Fan assembly for 1-slot Cassette, 25x25x10 mm

Cassette Modules

CSM-PoE354 (Nuvis-3304af-E Only)	Cassette module with PCIe-PoE354 and pre-installed passive heat-spreader
CSM-USB380 (Nuvis-3304af-E Only)	Cassette module with PCIe-USB380 and pre-installed passive heat-spreader

iVIS-200 Series

Intel® Atom™ E3845 Processor Board for x86-based Smart Camera Framework



CE FC

Key Features

- Intel® Atom™ E3845 quad-core 1.91 GHz
- Built-in GigE/ USB3.0/ USB2.0 camera interfaces
- Patented DTIO technology* for accurate trigger/strobe control
- Built-in 500 mA constant current and 24 V constant voltage LED controller
- 802.3at PoE+ PD and auxiliary DC dual power input
- Water-proof M12 connectors

*R.O.C Patent No. 1526834

Introduction

iVIS-200 consist of an Atom™ E3845 processing unit as part of an innovative smart camera framework that allows you to build up your own x86-based smart camera by integrating an off-the-shelf camera.

iVIS-200 features an ultra-compact footprint and it has GigE/ USB3.0/ USB2.0 camera interfaces. It also incorporates Neousys' DTIO technology for precise trigger/ strobe control and built-in constant current/ voltage LED controller for driving the LED light. Moreover, iVIS-200 carries 802.3at PoE+ PD (Powered Device) capability, so you can simply access and power your smart camera with just one Ethernet cable.

Targeted at different vertical markets, iVIS-200 series are available in several barebone configurations. iVIS-210B-MVS and iVIS-211B-MVS are designed for machine vision applications and come with a slim enclosure to accommodate Basler Dart and Point Grey Chameleon3 board camera, respectively. While iVIS-220B-ITS and iVIS-227B-ITS are aimed at intelligent traffic systems. They are equipped with an IP50 and an IP67 enclosure to accommodate a 29mm x 29mm USB3.0/ GigE camera. They also feature a mini-PCIe slot with SIM support for installing a 3G/ 4G/ WIFI module.

You can utilize iVIS-200 to construct an innovative framework and further expand the possibilities of your smart camera. With iVIS-200, you can quickly build your own smart camera based on Windows/Linux open platform and maximize your vision software.

Specifications

	iVIS-210B-MVS iVIS-211B-MVS	iVIS-220B-ITS iVIS-227B-ITS	iVIS-210B-MVS iVIS-211B-MVS	iVIS-220B-ITS iVIS-227B-ITS
System Core				
Processor	Intel® Atom™ Bay Trail-H E3845 quad-core processor			
Graphics	Integrated Intel® HD graphics			
Memory	Up to 8GB DDR3L-1333 (single SO-DIMM slot)			
On-board Camera Interface				
Ethernet	1x GigE interface by Intel® I210			
USB	1x USB3.0 interface			
Trigger I/O	1-CH trigger-out (to camera) and 1-CH strobe-in (from camera)			
Panel I/O Interface (M12 connectors)				
Ethernet	1x Gigabit Ethernet ports by Intel® I210			
Trigger Input	2-CH isolated trigger input (<2us L-to-H and H-to-L propagation delay)			
Strobe Output	1-CH isolated strobe output (24 VDC / 0.5 A rated)			
LED Illumination Controller	1-CH LED illumination driving output, supporting 24V DC constant voltage mode or 500 mA max. adjustable constant current mode with 100 KHz, 250 steps PWM dimming control			
COM	1x 3-wire RS-232			
Auxiliary I/O Interface (internal wafer connector)				
VGA	1x VGA port			
USB	1x USB 2.0 port			
Storage/Expansion Interface				
mSATA	1x half-size mSATA port			
Storage/Expansion Interface				
Mini-PCIe				1x full-size mini-PCIe socket with SIM support
OS Support				
Windows	Windows 7 32/ 64-bit, WE7			
Linux	Ubuntu 14.04, OpenSuSE 13.1, Fedora 20			
Power Supply				
PoE+ PD	Support IEEE 802.3at PoE+ PD (powered via Ethernet cable)			
Auxiliary DC-IN	Support 12/24V DC auxiliary power input when PoE+ PSE is not available			
Mechanical				
Dimension	83mm (W) x 48mm (D) x 150mm (H)		88mm (W) x 151mm (D) x 74mm (H)	
Weight	0.55 kg		0.95 kg	
Environmental				
Operating Temperature	-25°C ~ 60°C, 100% CPU loading */**			
Storage Temperature	-40°C ~ 85°C			
Humidity	10%~90% , non-condensing			
Vibration	Operating, 5 Grms, 5-500 Hz, 3 Axes (w/ SSD, w/ o add-on card, according to IEC60068-2-64)			
Shock	Operating, 50 Grms, Half-sine 11 ms Duration (w/ SSD, w/ o add-on card, according to IEC60068-2-27)			
EMC	CE/FCC Class A, according to EN 55022 & EN 55024			

* When using built-in LED illumination controller to drive LED light, 24 VDC input is required to meet the rated current of the M12 connector
 ** The 100% CPU loading is applied using Passmark® BurnInTest™ v7.0. For detail testing criteria, please contact Neousys Technology

Appearance

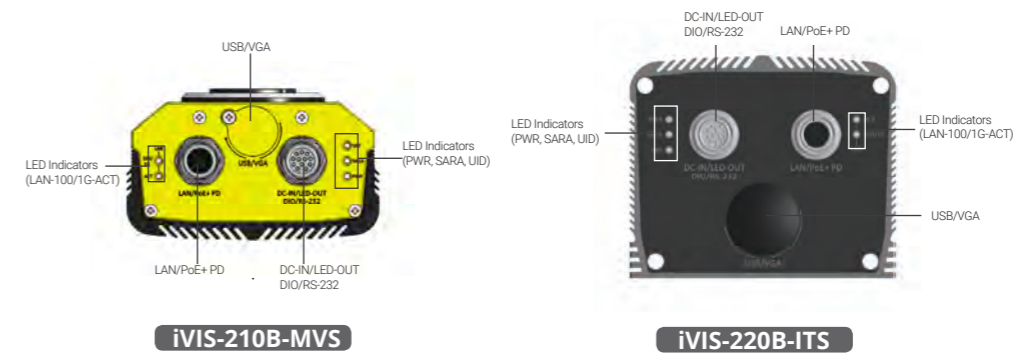

Dimensions

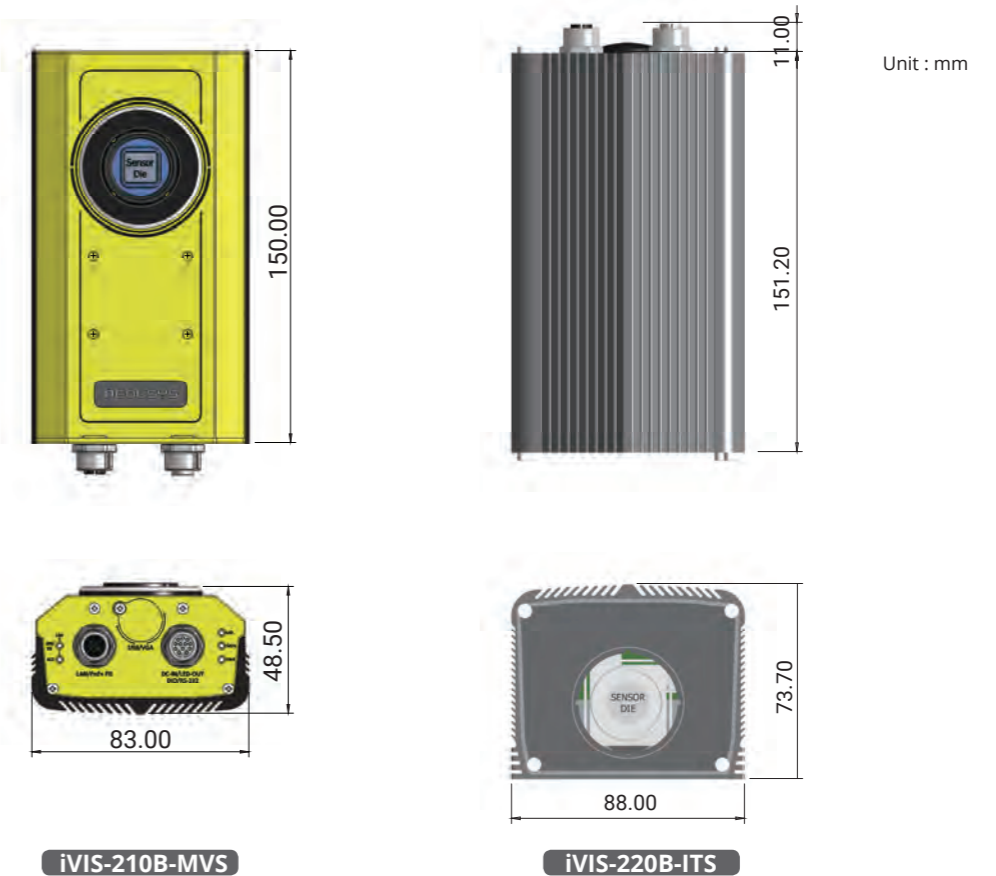

Ordering Information

Model No.	Product Description
iVIS-210B-MVS	Intel® Atom™ E3845 smart camera framework for MV application, accommodating Basler Dart camera (CS-mount)
iVIS-211B-MVS	Intel® Atom™ E3845 smart camera framework for MV application, accommodating Point Grey chameleon3 camera (CS-mount)
iVIS-220B-ITS	Intel® Atom™ E3845 smart camera framework for ITS application, accommodating COTS 29mm x 29mm USB3/GigE camera, with IP50 enclosure
iVIS-227B-ITS	Intel® Atom™ E3845 smart camera framework for ITS application, accommodating COTS 29mm x 29mm USB3/GigE camera, with IP67 enclosure

Optional Accessories

- Cable kit for USB3.0 camera
- Cable kit for GigE camera

PCIe-PoE550X

2-port 10GbE Network Adapter with IEEE 802.3at PoE+ Capability



Key Features

- Two 10 GbE ports; Intel® X550-AT2 10 GigE controller
- Gen3 PCI Express x4 interface
- Supports 10GbE with CAT-6/ 6a cable (Max. 100 meters)
- Supports 10GbE 802.3at PoE+ with CAT 6a cable
- Supports NBASE-T and 1000BASE-T with CAT-5/ 5e cable
- Compliant with IEEE 802.3at to deliver 25.5W each port
- Supports 15.5 KB jumbo frame, NIC teaming and IEEE 1588
- Per-port PoE+ power on/off control via API

CE FC

Introduction

Introducing the world's first 10Gbit Ethernet NIC incorporating IEEE 802.3at PoE+ capability, featuring Intel® X550-AT2, Neousys Technology's PCIe-PoE550X offers cost-effective 10GBASE-T solution for growing 10GbE applications.

PCIe-PoE550X features 10GbE NIC incorporating Power over Ethernet (PoE+) capability. It features Neousys' proven 802.3at PoE+ technology and refined power design to ensure optimal signal integrity over 10G PHY and maximal bandwidth. The combination of 10GbE and PoE opens the door to new applications such as high-performance WiFi access points and high-speed/ high-definition industrial cameras over single Ethernet cable.

10GBASE-T leverages twisted-pair copper cable and RJ45 connector that dramatically reduces the deployment cost of 10G network. PCIe-PoE550X provides 10Gbit/s connections over a distance of up to 100 meters with CAT 6a cable or 55 meters with CAT 6 cable. It also supports upcoming NBASE-T standard as well as backward compatibility with existing 1000BASE-T GbE network so you can easily implement it into your current network infrastructure.

Specifications

Bus Interface	Gen3 PCI Express x4
# of 10 GbE Port	2x 10 GbE ports by Intel® X550-AT2 controller, supporting 15.5 KB jumbo frame, teaming and IEEE 1588
Network Protocol Support	IEEE 802.3 Ethernet interface for 10GBASE-T (IEEE 802.3an), NBASE-T (IEEE 802.3bz) and 1000BASE-T (IEEE 802.3ab)
PoE Capability	Optional IEEE 802.3at-2009 (PoE+), each port delivers up to 25.5 W of power
Cable Requirement	For 10GBASE-T: CAT 6a (100 meters) or CAT 6 (55 meters) For 5Gbps NBASE-T: CAT 6 (100 meters) For 2.5Gbps NBASE-T: CAT 5e (100 meters)
Power Requirement	Maximum 11.5W for 2x 10 GbE operation Maximum 51W for powering PoE+ devices
EMC	CE Class A, according to EN 55024/ 55032 FCC Class A, according to FCC Part 15, Subpart B
EMS	IEC 61000-4-x Class/ Level 3
Operating Temperature	0°C ~ 60°C with air flow
Dimension	167.7 mm (W) x 111.2 mm (H)

Ordering Information

Model No.	Product Description
PCIe-PoE550X	2-port 10GbE Network Adapter with IEEE 802.3at PoE+ Capability

PCIe-PoE334LP

Low-profile 4-port Server-grade Gigabit PoE+ Card with 1 kV Surge Protection



CE FC

Key Features

- Low-profile form-factor
- 4x ports via Intel® I350-AM4 server-grade GigE controller
- Compliant with IEEE 802.3at to deliver 25.5 W each port
- IEC 61000-4-5 Class 2 surge immunity
- Supports 9.5 kB jumbo frame, teaming and IEEE 1588
- Per-port PoE+ power on/ off control via software API

Introduction

PCIe-PoE334LP is the latest member of Neousys' PoE NIC card family. It is the world's first PoE card to integrate 4-port server-grade GigE controller and 802.3at PoE+ into a low-profile PCIe card. The low-profile form-factor makes PCIe-PoE334LP the perfect solution for commercial off-the-shelf 2U server computers.

PCIe-PoE334LP is designed with state-of-the-art Intel® I350-AM4 GigE controller to offer extraordinary Ethernet performance. It inherits Neousys' proven PoE technology to power your machine vision cameras and surveillance IP cameras. In addition, PCIe-PoE334LP features solid surge protection design compliant with IEC 61000-4-5 Class 2. It is capable of withstanding 1 kV surge and 8 kV ESD on signal lines. This is particularly valuable for outdoor surveillance system or factory automation equipment where power surge may damage the system through the Ethernet connection.

Incorporating low-profile form-factor and robust surge protection, PCIe-PoE334LP defines a new category of PoE card - a compact and yet solid PoE card for servers and rugged industrial applications.

Specifications

Bus Interface	x4, Gen2 PCI Express
Gigabit Ethernet Port	4x GigE ports by Intel® I350-AM4 controller, supporting 9.5 kB jumbo frame, teaming and IEEE 1588
PoE Capability	In compliance with IEEE 802.3at-2009 (PoE+), each port delivers up to 25.5 W of power 75W total power budget (limited by PCI Express bus)
Cable Requirement	CAT-5e or CAT-6 cable, 100 meters maximal
Power Requirement	Maximum 1.2 A @ 3.3 V from PCI Express bus Maximum 6.2A @ 12 V from PCI Express bus
EMC	CE Class A, according to EN 55022/ 55024/ 55032 FCC Class A, according to FCC Part 15, Subpart B
EMS	IEC 61000-4-x Class/ Level 2
Operating Temperature	0°C ~ 55°C with air flow
Dimension	168 mm (W) x 69 mm (H)

Ordering Information

Model No.	Product Description
PCIe-PoE334LP	Low-profile 4-port server-grade Gigabit 802.3at PoE+ card with 1 kV surge protection

PCIe-PoE354at/PoE352at

4-Port / 2-Port Server-grade Gigabit 802.3at PoE+ Frame Grabber Card

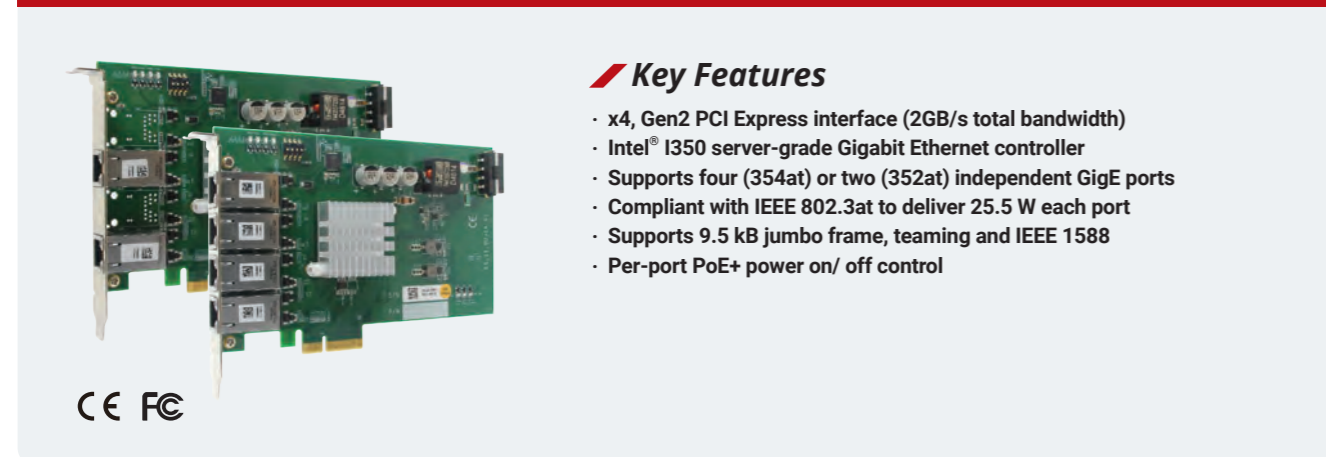

Key Features

- x4, Gen2 PCI Express interface (2GB/s total bandwidth)
- Intel® I350 server-grade Gigabit Ethernet controller
- Supports four (354at) or two (352at) independent GigE ports
- Compliant with IEEE 802.3at to deliver 25.5 W each port
- Supports 9.5 kB jumbo frame, teaming and IEEE 1588
- Per-port PoE+ power on/ off control

Introduction

PCIe-PoE354at is world's first PoE frame grabber card combining server-grade GigE controller and 802.3at PoE+ capability. Inheriting Neousys' expertise on PoE technology, PCIe-PoE354at further incorporates the updated 802.3at-2009 standard and offers up to 25.5W of power each port.

PCIe-PoE354at is designed with state-of-the-art Intel® I350 Gigabit Ethernet controller. This server-grade GigE controller incorporates advanced features such as checksum offloading, segmentation offloading and intelligent interrupt generation/ moderation to increase overall Ethernet performance and reduce CPU utilization. In addition, its single-bus, multi-port topology minimizes compatibility issues with off-the-shelf motherboards when installing multiple cards.

Machine vision applications can be benefited by PCIe-PoE354at's server-grade network performance. Its 25.5W PoE+ can now power PTZ (pan-tilt-zoom) cameras for surveillance applications. With an excellent cost-per-performance ratio, PCIe-PoE354at is your ideal Power over Ethernet solution.

Specifications

	PCIe-PoE354at	PCIe-PoE352at
Bus Interface	x4, Gen2 PCI Express	
Gigabit Ethernet Port	4x GigE ports by Intel® I350-AM4 controller, supporting 9.5 kB jumbo frame, teaming and IEEE 1588	2x GigE ports by Intel® I350-AM2 controller, supporting 9.5 kB jumbo frame, teaming and IEEE 1588
PoE Capability	In compliant with IEEE 802.3at-2009 (PoE+), each port delivers up to 25.5 W of power	
Cable Requirement	CAT-5e or CAT-6 cable, 100 meters maximum	
Power Requirement	Maximum 1.2A @ 3.3V from PCI Express bus Maximum 9.6A @ 12V from PCI Express bus or on-board 4-pin power connector*	Maximum 0.9A @ 3.3V from PCI Express bus Maximum 4.8A @ 12V from PCI Express bus**
Operating Temperature	0°C – 55°C with air flow	
Dimension	168 mm (W) x 111 mm (H)	

* PCIe-PoE354at is designed to obtain 12 VDC for PoE devices from either PCI Express bus or on-board 4-pin power connector according to a user-configurable jumper.
** PCIe-PoE352at is designed to obtain 12 VDC for PoE devices directly from PCI Express bus. No external 12 VDC is needed.

Ordering Information

Model No.	Product Description
PCIe-PoE354at	4-Port Intel® I350-AM4 server-grade Gigabit 802.3at PoE+ frame grabber card
PCIe-PoE352at	2-Port Intel® I350-AM2 server-grade Gigabit 802.3at PoE+ frame grabber card

PCIe-USB380/USB340

8-Port/ 4-Port USB3.0 Host Adapter Card with 4x Independent USB3.0 Controllers

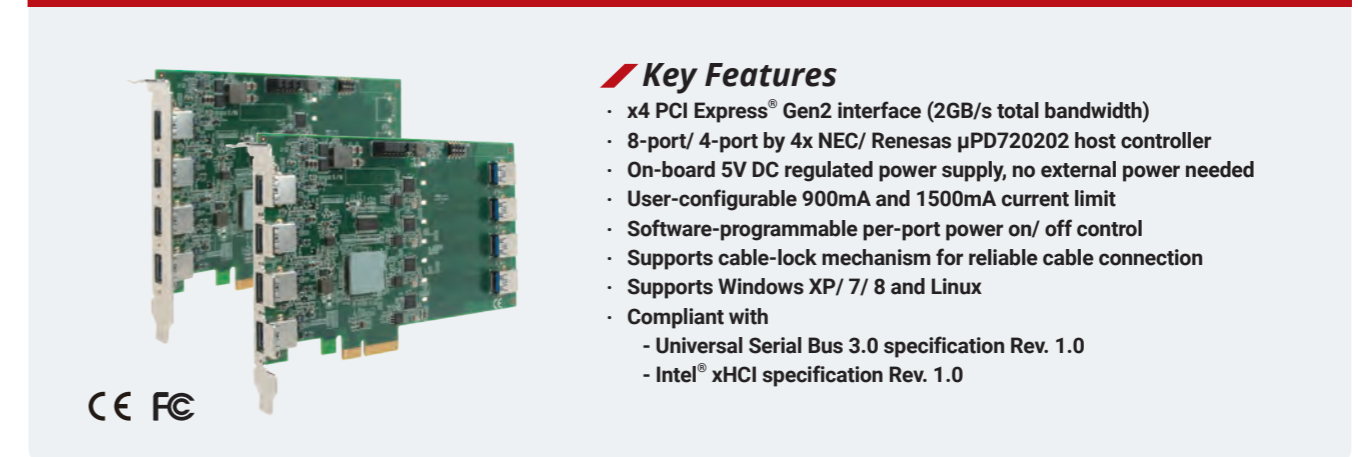

Key Features

- x4 PCI Express® Gen2 interface (2GB/s total bandwidth)
- 8-port/ 4-port by 4x NEC/ Renesas μPD720202 host controller
- On-board 5V DC regulated power supply, no external power needed
- User-configurable 900mA and 1500mA current limit
- Software-programmable per-port power on/ off control
- Supports cable-lock mechanism for reliable cable connection
- Supports Windows XP/ 7/ 8 and Linux
- Compliant with
 - Universal Serial Bus 3.0 specification Rev. 1.0
 - Intel® xHCI specification Rev. 1.0

Introduction

Neousys PCIe-USB380/ 340 is an 8-port/ 4-port USB3.0 host adapter specifically designed for industrial and vision applications. USB3.0 or SuperSpeed USB, delivers up to ten times the data rate over USB2.0 and is particularly useful for high-speed data storage and imaging devices.

Most off-the-shelf USB3.0 cards implement multiple ports with single USB3.0 controller which results in significant performance degradation during multi-port operation. To achieve maximum per-port performance, PCIe-USB380 has four independent NEC/ Renesas μPD720202 USB3.0 Host Controllers and x4 PCI Express® Gen2 interface to offer up to 5 Gbps bandwidth for each port when four ports simultaneously. In addition to transfer data bandwidth advantage, PCIe-USB380/ 340 features on-board regulated 5V DC power supply with a unique design with configurable 900mA/ 1500mA current limit to supply stable 5V DC power to external USB devices. It also supports software-programmable per-port power on/ off control for fault recovery operations.

Combining high bandwidth, industrial-grade power design and reliable cable connection, PCIe-USB380/ 340 brings convenience to interface USB3.0 devices operating under Windows XP, 7, 8 and Linux.

Specifications

	PCIe-USB380	PCIe-PoE340
USB Ports	8x USB3.0 ports, compatible with USB2.0/ 1.1/ 1.0	4x USB3.0 ports, compatible with USB2.0/ 1.1/ 1.0
USB Connectors	4x panel-accessible USB3.0 Type-A connectors with M2 screw threads 4x on-board USB3.0 Type-A connectors with fix points for cable tie	4x panel-accessible USB3.0 Type-A connectors with M2 screw threads
Bus Interface	4-lanes, Gen2 PCI Express interface, compliant with PCI Express Base specification revision 2.0	
USB Controller	4x NEC/ Renesas μPD720202 host controllers Compliant with Universal Serial Bus 3.0 specification revision 1.0 Compliant with Intel® xHCI specification revision 1.0	
USB Per-Port Current Limit	User-configurable 900mA/1500mA per-port current limit	
Power Requirement	Maximum 2.0A @ 3.3V from PCI Express bus Maximum 5.5A @ 12V from PCI Express bus for devices	Maximum 2.0A @ 3.3V from PCI Express bus Maximum 2.8A @ 12V from PCI Express bus for devices
Operating Temperature	0°C – 60°C with ambient air flow	
Dimension	168 mm (W) x 111 mm (H)	

Ordering Information

Model No.	Product Description
PCIe-USB380	8-Port USB3.0 host adapter with 4x independent USB3.0 controllers
PCIe-USB340	4-Port USB3.0 host adapter with 4x independent USB3.0 controllers

Optional Accessories

USB3-Cable-3M	USB3 Type-A to Micro-B cable with latched connectors, 3-meter length
---------------	--

POC-351VTC Series

Intel® Apollo Lake Atom™ E3950 Ultra-compact In-vehicle Controller with GbE, PoE+ and Isolated CAN bus



CE FC

Key Features

- Intel® Apollo Lake Atom™ E3950 quad-core processor
- Rugged, optional -40 °C to 70 °C fanless operation
- Two IEEE 802.3at PoE+ ports and one GbE port
- One isolated CAN bus port for in-vehicle communication
- One M.2 socket and three mPCIe sockets
- Aluminum heat-spreader for M.2/ mPCIe modules
- 4-CH isolated DI and 4-CH isolated DO
- 8~35V DC input with built-in ignition power control

Introduction

POC-351VTC is an ultra-compact, fanless in-vehicle controller powered by Intel® Apollo Lake Atom™ E3950 quad-core processor. It combines finesse performance, extraordinary reliability and affordability for versatile in-vehicle applications.

POC-351VTC offers two PoE+ ports to power devices such as IP cameras, and one additional GbE port for data communication. It also features isolated CAN bus 2.0 port and RS-232/ 422/ 485 ports for communicating with other automotive devices. Wide-range DC input and ignition power control make POC-351VTC fit for various vehicle types.

Wireless and internet access is essential for modern day in-vehicle applications and POC-351VTC has a total of four M.2/ mPCIe sockets and six antenna holes to accommodate a variety of 4G, 3G, WIFI and GPS modules. An aluminum heat-spreader is thoughtfully designed to dissipate heat generated by modules to maintain superior operating stability, for the system and communication modules.

Specifications

System Core		Power Supply	
Processor	Intel® Atom™ E3950 1.6/ 2.0 GHz quad-core processor	DC Input	8~35 VDC
Graphics	Integrated Intel® HD Graphics 505	Input Connector	3-pin pluggable terminal block for DC input (IGN/ GND/ V+)
Memory	Up to 8GB DDR3L-1866 (single SO-DIMM slot)	Mechanical	
Panel I/O Interface		Dimension	153 mm (W) x 108 mm (D) x 56 mm (H)
Ethernet	3x Gigabit Ethernet ports by Intel® I210 GbE controller	Weight	1.0 kg
PoE	IEEE 802.3at PoE+ on port #2 and #3	Mounting	Horizontal wall-mount (standard) or vertical wall-mount (optional)
Video Port	VGA and DVI dual display outputs via DVI-I connector	Environmental	
USB	2x USB3.0 ports and 2x USB 2.0 ports	Operating Temperature	-25°C ~ 70°C **/***
Serial Port	• 1x software-programmable RS-232/ 422/ 485 ports (COM1) • 3x 3-wire RS-232 ports (COM2/ COM3/ COM4) • 1x RS-422/485 port (COM2)	Storage Temperature	-40°C ~ 85°C**
Audio	1x Mic-in and 1x speaker-out	Humidity	10%~90% , non-condensing
CAN bus	1x isolated CAN 2.0 port	Vibration	Operating, 5 Grms, 5-500 Hz, 3 Axes (w/ mSATA, according to IEC60068-2-64)
Isolated DIO	4x isolated DI and 4x isolated DO	Shock	Operating, 50 Grms, Half-sine 11 ms Duration (w/ mSATA, according to IEC60068-2-27)
Internal I/O Interface		EMC	E-Mark for in-vehicle applications CE/ FCC Class A, according to EN 55032 & EN 55024
M.2	1x M.2 B key socket for 3G/ 4G option with USIM support	* For wide temperature use condition, a wide temperature/industrial mSATA module is required.	
Mini-PCIe	3x full-size mini PCI Express sockets with USIM support	** For full function use condition (mini-PCIe, M.2, and mSATA are all adopted), the recommended operating temperature is -25°C ~ 60°C	
Storage Interface		*** For extreme wide temperature -40°C ~ 70°C, it is optional with 100% screening, please contact Neosys Technology	
mSATA	1x half-size mSATA port 1x full-size mSATA port		

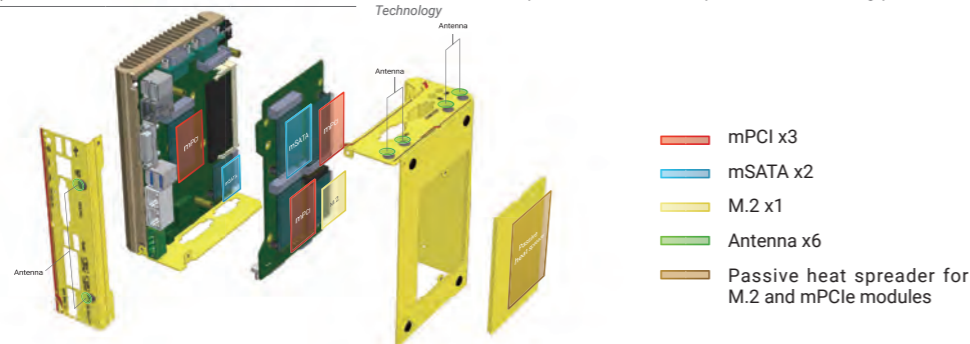

- mPCI x3
- mSATA x2
- M.2 x1
- Antenna x6
- Passive heat spreader for M.2 and mPCIe modules

Appearance

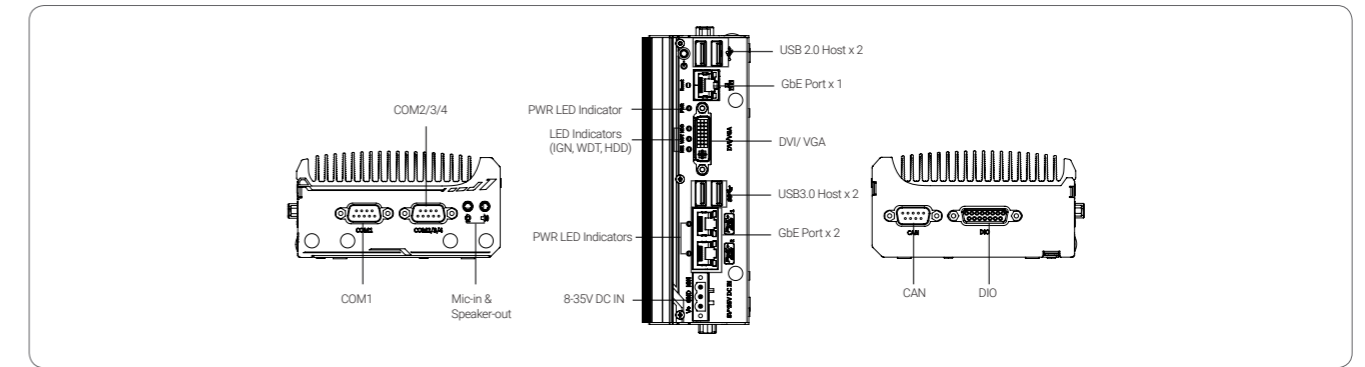

Dimensions

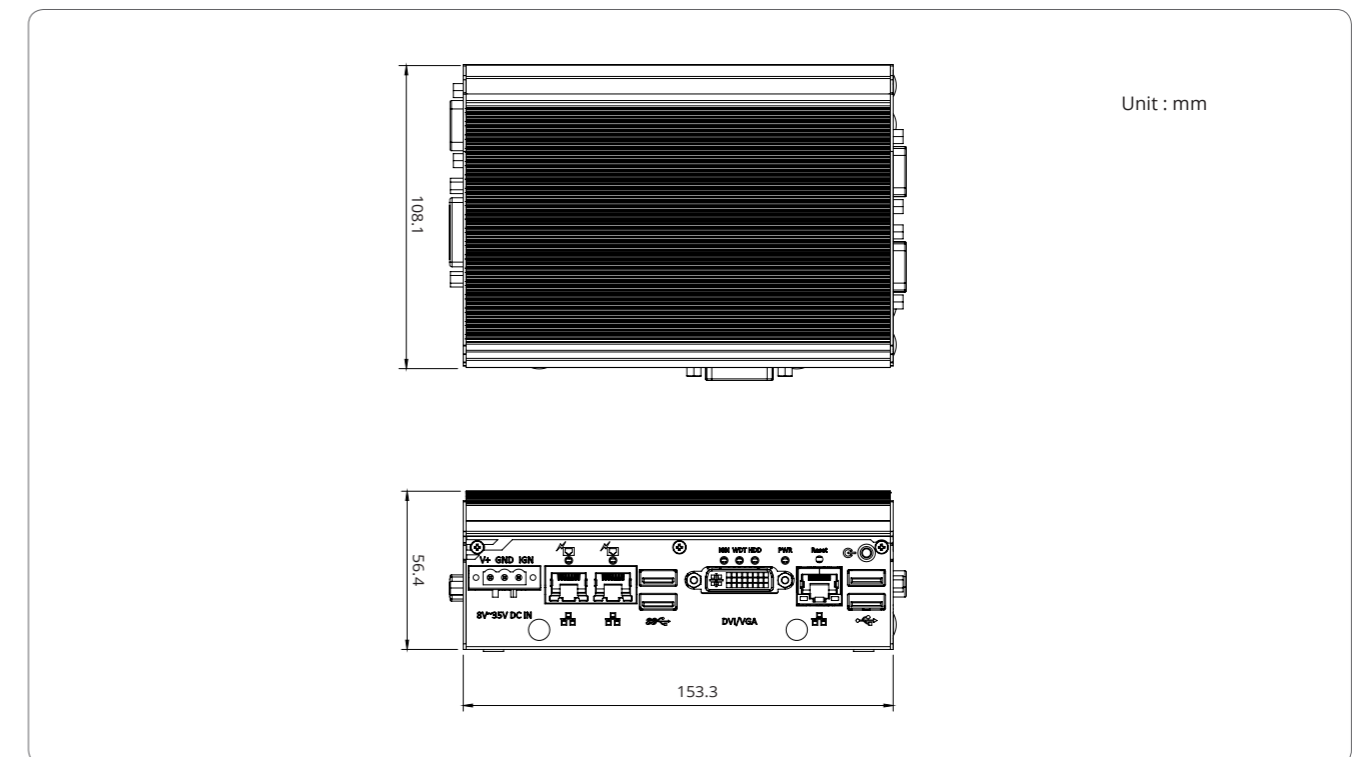

Ordering Information

Model No.	Product Description
POC-351VTC	Intel® Apollo Lake Atom™ E3950 ultra-compact in-vehicle controller with 1x GbE, 2x PoE+ and Isolated CAN

Optional Accessories

64GB mSATA mini SSD with pre-installed Windows 10 IoT English version*	
128GB mSATA mini SSD with pre-installed Windows 10 IoT English version*	
PA-60W-OW	60W AC/DC power adapter with 12V, 5A DC output, cord end terminals for terminal block. operating temperature : -30 to 60 °C.
WM-300V	Wall mounting assembly for POC-351VTC, vertical type

* For Windows 10 IoT with other language packages, MOQ is required. Please contact Neosys for further information.

Nuvo-5100VTC Series

Intel® 6th-Gen Core™ i7/i5/i3 In-Vehicle Controller with 4x or 8x PoE+ Ports, DIO, CAN bus and RAID



Key Features

- Supports Intel® 6th-Gen Core™ i7/ i5/ i3 LGA1151 socket-type CPU
- 4x or 8x 802.3at Gigabit PoE+ ports via M12 or RJ45 connectors
- On-board CAN bus for in-vehicle communication
- 4-CH isolated DI and 4-CH isolated DO
- 2x SATA ports with one hot-swappable HDD tray, supporting RAID 0/ 1
- 4x full-size mini-PCIe sockets with SIM support
- 8~35V wide-range DC input with built-in ignition power control
- EN 50155 certificate & E13 No. 10R-0514321



Introduction

Nuvo-5100VTC is a state-of-the-art in-vehicle controller in compliant with E-Mark and EN 50155 certificate. Featuring Intel® 6th-Gen Core™ CPU, it exhibits superb CPU and GPU performance for various in-vehicle applications.

Nuvo-5100VTC offers four or eight 802.3at PoE+ ports to supply 25W power to the connected device. They are implemented using RJ45 or M12 (x-coded connectors), which guarantee extremely rugged connection in shock/ vibration environments. Two more Gigabit Ethernet ports by RJ45 are available for data communication. You can also utilize four internal mini-PCIe sockets with corresponding modules for 3G/ 4G/ WIFI/ GPS communication.

In addition, Nuvo-5100VTC integrates CAN bus for in-vehicle communication, and isolated DIO for sensor/ actuator control. Combining ignition power control and dual-drive RAID storage, Nuvo-5100VTC is the perfect solution for all your in-vehicle application needs.

Specifications

System Core	
Processor	Supports Intel® 6th-Gen Core™ i7/ i5/ i3 LGA1151 CPU - Intel® Core™ i7-6700TE (8M Cache, 2.4/ 3.4 GHz, 35W TDP) - Intel® Core™ i5-6500TE (6M Cache, 2.3/ 3.3 GHz, 35W TDP) - Intel® Core™ i3-6100TE (4M Cache, 2.7 GHz, 35W TDP)
Chipset	Intel® Q170 Platform Controller Hub
Graphics	Integrated Intel® HD Graphics 530
Memory	Up to 32 GB DDR4-2133 SDRAM (two SO-DIMM slots)
AMT	Supports AMT 11.0
TPM	Supports TPM 2.0
I/O Interface	
Ethernet	2x Gigabit Ethernet ports by Intel® I219 and I210
PoE+	4x IEEE 802.3at (25.5W) Gigabit PoE+ ports by Intel® I210, - M12 x-coded connector (Nuvo-5100VTC); - RJ45 connector (Nuvo-5104VTC) 8x IEEE 802.3at (25.5W) Gigabit PoE+ ports by Intel® I210 - RJ45 connector (Nuvo-5108VTC)
CAN	1x CAN 2.0 port
Isolated DIO	4x isolated DI and 4x isolated DO
USB	4x USB3.0 ports via native xHCI controller 4x USB2.0 ports
Video Port	1x stacked VGA + DVI-D connector 2x DisplayPort connectors, supporting 4K2K resolution
Serial Port	2x software-programmable RS-232/422/485 port (COM1 & COM3) 1x RS-232 port (COM2)
Audio	1x Mic-in and 1x speaker-out
Storage Interface	
SATA HDD	1x hot-swappable HDD tray for 2.5" HDD/ SSD installation 1x Internal SATA port for 2.5" HDD/ SSD installation, supporting RAID 0/ 1
Storage Interface	
mSATA	1x full-size mSATA port (mux with mini-PCIe)
Expansion Bus	
Mini PCI-E	1x full-size mini-PCIe socket with panel-accessible SIM socket 1x full-size mini-PCIe socket with internal SIM socket (mux. with mSATA) 2x full-size mini-PCIe sockets (USB signals only) with internal SIM sockets
Power Supply	
DC Input	1x 3-pin pluggable terminal block for 8~35V DC input
Remote Ctrl. & Status Output	1x 10-pin (2x5) wafer connector for remote on/ off control and status LED output
Mechanical	
Dimension	240 mm (W) x 225 mm (D) x 79 mm (H)
Weight	3.3 kg
Mounting	Neosys' patented damping bracket (standard) or optional DIN-rail mounting
Environmental	
Operating Temperature	-40°C ~ 70°C */**
Storage Temperature	-40°C ~ 85°C
Humidity	10%~90% , non-condensing
Vibration	Operating, 5 Grms, 5-500 Hz, 3 Axes (w/ SSD, according to IEC60068-2-64)
Shock	Operating, 50 Grms, Half-sine 11 ms Duration (w/ SSD, according to IEC60068-2-27)
Certification	EN 50155 (Nuvo-5100VTC), E-Mark (Nuvo-5108VTC) CE/ FCC Class A, according to EN 55022, EN 55024 & EN 55032

*The CPU loading is applied using Passmark® BurnInTest 8.0. For detail testing criteria, please contact Neosys Technology
** For sub-zero operating temperature, a wide temperature HDD drive or Solid State Disk (SSD) is required.

Appearance

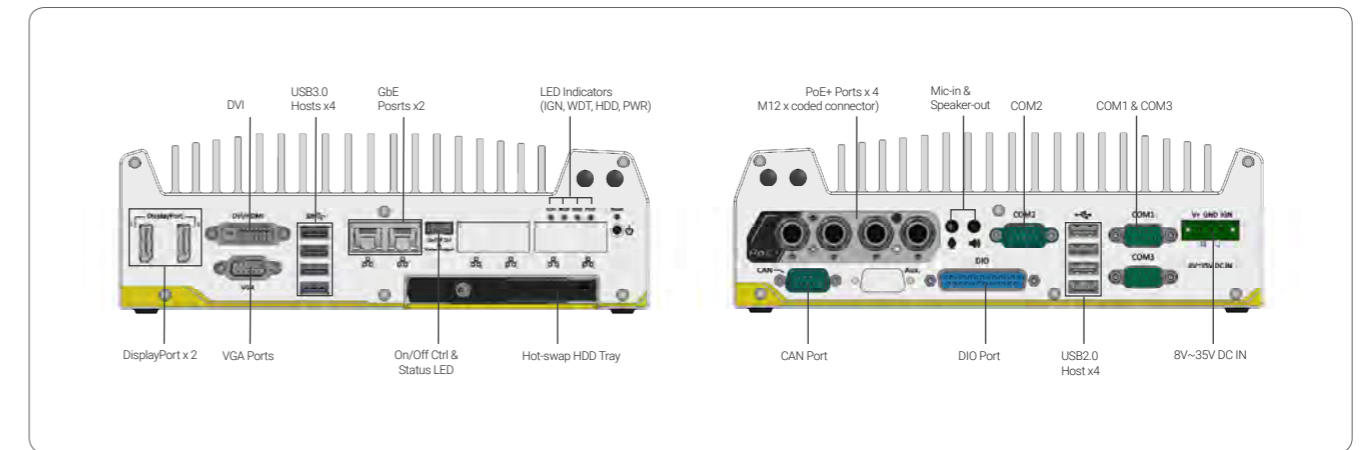

Dimensions

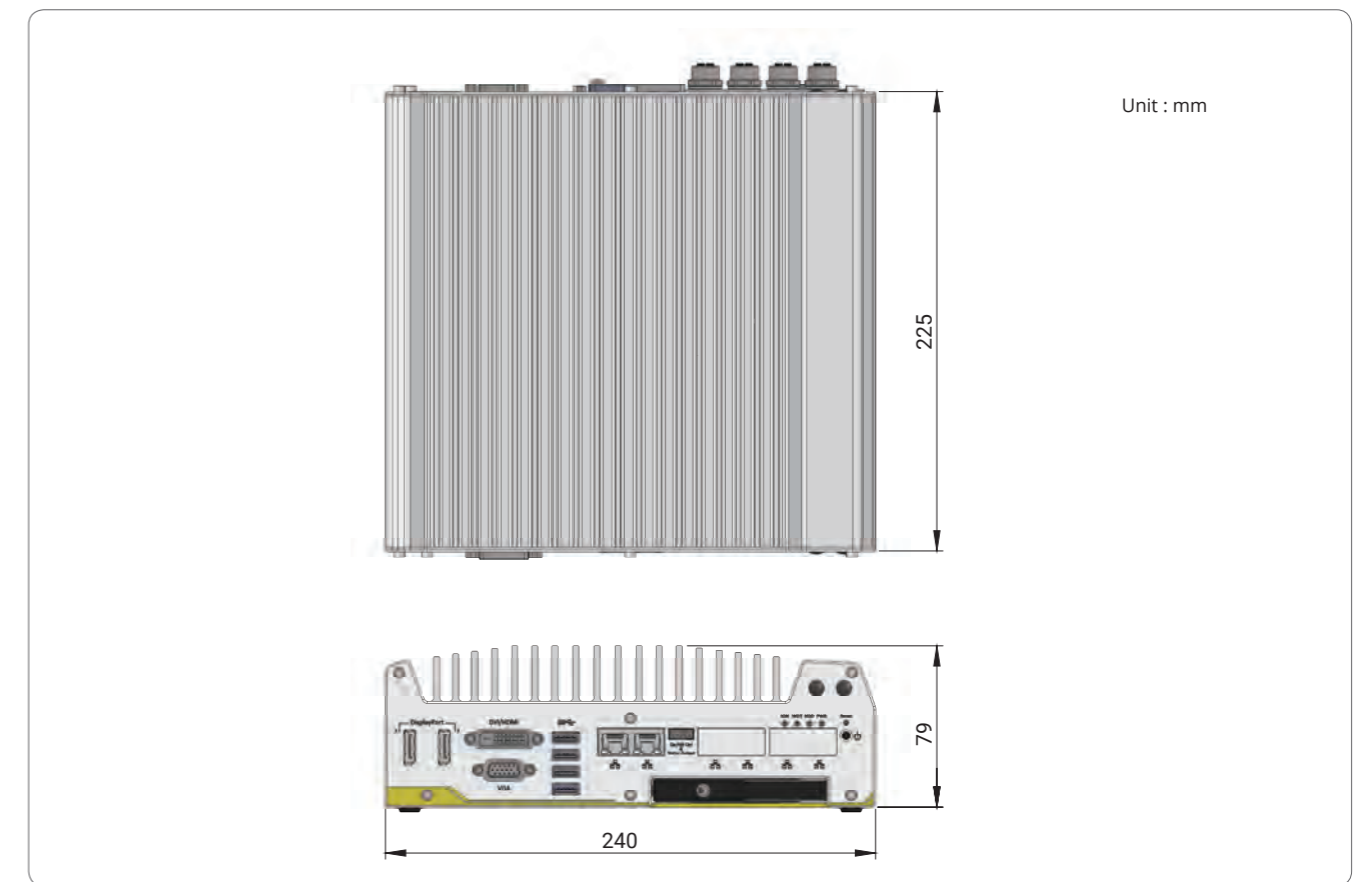

Ordering Information

Model No.	Product Description
Nuvo-5100VTC	Intel® 6th-Gen Core™ i in-vehicle controller with 4x M12 PoE+ Ports, DIO, CAN bus and RAID
Nuvo-5104VTC	Intel® 6th-Gen Core™ i in-vehicle controller with 4x RJ45 PoE+ Ports, DIO, CAN bus and RAID
Nuvo-5108VTC	Intel® 6th-Gen Core™ i in-vehicle controller with 8x RJ45 PoE+ Ports, DIO, CAN bus and RAID

Optional Accessories

C-M12-RJ45-LAN-5M	M12(8-pole-X-coded) to RJ45, CAT6, length : 5M
C-M12-RJ45-LAN-10M	M12(8-pole-X-coded) to RJ45, CAT6, length : 10M
DINRAIL-O	DIN-rail mounting assembly for Nuvo-5100VTC series
PA-120W-OW	120W AC/DC power adapter 20V/6A; 18AWG/120cm; cord end terminals for terminal block, operating temperature : -30 to 70 °C.

Nuvo-3100VTC Series

Intel® 3rd-Gen Core™ i7/ i5 Fanless In-vehicle Controller with 4x 802.3at PoE+ Ports and Dual 2.5" Hard Drives with RAID Support



Key Features

- Compact dimensions, 212 mm x 165 mm x 62 mm
- Intel® 3rd-Gen i7/ i5 PGA-type processor
- 4x IEEE 802.3at (25.5W) Gigabit PoE+ ports
- Dual 2.5" SATA ports with one easy-swap HDD tray
- Patented damping bracket* for in-vehicle installation
- 8 ~ 35V wide-range DC input and built-in ignition power control
- 3x mini-PCIe/ mSATA slots for 3G/ WIFI/ GPS module installation
- E13 No. 10R-0413512 and EN 50155/EN 50121-3-2 certificate



*R.O.C Patent No. M491752

Introduction

Nuvo-3100VTC is a fanless controller with E-Mark and EN 50155/ EN 50121-3-2 certificate for in-vehicle use. It supports 3rd-Gen i7 quad-core CPU for to meet most in-vehicle computing needs. There are also four IEEE 802.3at PoE+ ports to facilitate Ethernet connectivity and power IP cameras for surveillance applications.

Nuvo-3100VTC takes into account all demands of in-vehicle applications. It has a very compact footprint to fit into restricted space, allows 8~35V wide-range DC input and enhanced surge protection to make Nuvo-3100VTC highly robust when implemented in an in-vehicle environment. Nuvo-3100VTC support dual 2.5" hard drives in RAID configuration (RAID 0/ 1) or alternatively, take advantage of the easy-swap HDD tray for easy HDD replacement (non-RAID configuration). For in-vehicle installation, our patented mounting bracket can absorb shock/ vibration and extend overall system reliability.

Combining superior performance, PoE+ and comprehensive design, Nuvo-3100VTC offers more possibilities for in-vehicle applications!

Specifications

	Nuvo-3100VTC	Nuvo-3110VTC		Nuvo-3100VTC	Nuvo-3110VTC
System Core					
Processor	Supports the following CPU - Intel® Core™ i7-3610QE (2.3/ 3.3 GHz, 6 MB cache) - Intel® Core™ i5-3610ME (2.7/ 3.3 GHz, 3 MB cache) - Intel® Celeron™ 1020E (2.2 GHz, 2 MB cache)		Power Supply & Ignition Control		
Chipset	Intel® QM77 Platform Controller Hub with AMT & RAID support		DC Input	1x 3-pin pluggable terminal block for 8-35V DC input	
Graphics	Integrated Intel® HD Graphics 4000 Controller		Ignition Control	Ignition power control with user-selectable on/ off delay	
Memory	Up to 8GB DDR3 1333/ 1600 MHz SDRAM (single SO-DIMM slot)		Mechanical		
I/O Interface			Dimension	212 mm (W) x 165 mm (D) x 62 mm (H)	
Ethernet	1x Gigabit Ethernet port by Intel® 82579LM, supporting Wake-on-LAN 3x Gigabit Ethernet ports by Intel® I210		Weight	2.8 kg (incl. CPU, memory and HDD)	
PoE	Compliant to IEEE 802.3at (25.5W) with per-port power on/ off control 75W total power budget for 4x PoE+ ports		Mounting	Damping bracket (standard) or DIN-rail mounting (optional)	
Video Port	1x DVI-I connector for VGA/DVI output, supporting 2048x1536 (VGA) or 1920x1080 (DVI) resolution 2x DisplayPort, supporting 2560x1600 resolution		Environmental		
USB	4x USB3.0 ports and 2x USB2.0 ports		Operating Temperature	Maximum Performance	-25°C ~ 50°C**
Serial Port	2x software-programmable RS-232/ 422/ 485 (COM1 & COM2)			Reduced Performance	-25°C ~ 60°C**
Isolated DIO	4x isolated DI with COS interrupt and 4x isolated DO			Extended Temperature	-25°C ~ 70°C**
Audio	1x Mic-in and 1x speaker-out			Storage Temperature	-40°C ~ 85°C**
Storage Interface			Humidity	10%~90%, non-condensing	
SATA HDD	1x internal SATA port for 2.5" HDD/ SSD 1x easy-swap HDD tray for 2.5" HDD/ SSD		Vibration	Operating, 1 Grms, 5-500 Hz, 3 Axes (w/ HDD, according to IEC60068-2-64) Operating, 5 Grms, 5-500 Hz, 3 Axes (w/ SSD, according to IEC60068-2-64)	
mSATA	1x full-size mSATA (SATA/ USB/ W_DISABLE#) with USIM socket		Shock	Operating, 50 Grms, Half-sine 11 ms Duration (w/ SSD, according to IEC60068-2-27)	
Expansion Bus			Certification	E-Mark for vehicle applications EN 50155/ EN 50121-3-2 CE/ FCC Class A, according to EN 55022 & EN 55024	
Mini PCI-E	1x full-size mini PCI Express socket with USIM socket 1x half-size mini PCI Express socket		* The CPU loading is applied using Passmark® BurnInTest 8.0. For detail testing criteria, please contact Neosys Technology ** For sub-zero operating temperature, a wide temperature HDD drive or Solid State Disk (SSD) is required.		

Appearance

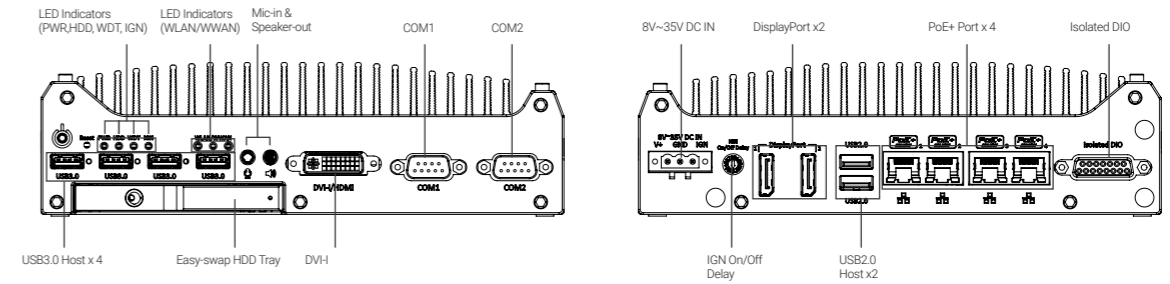

Dimensions

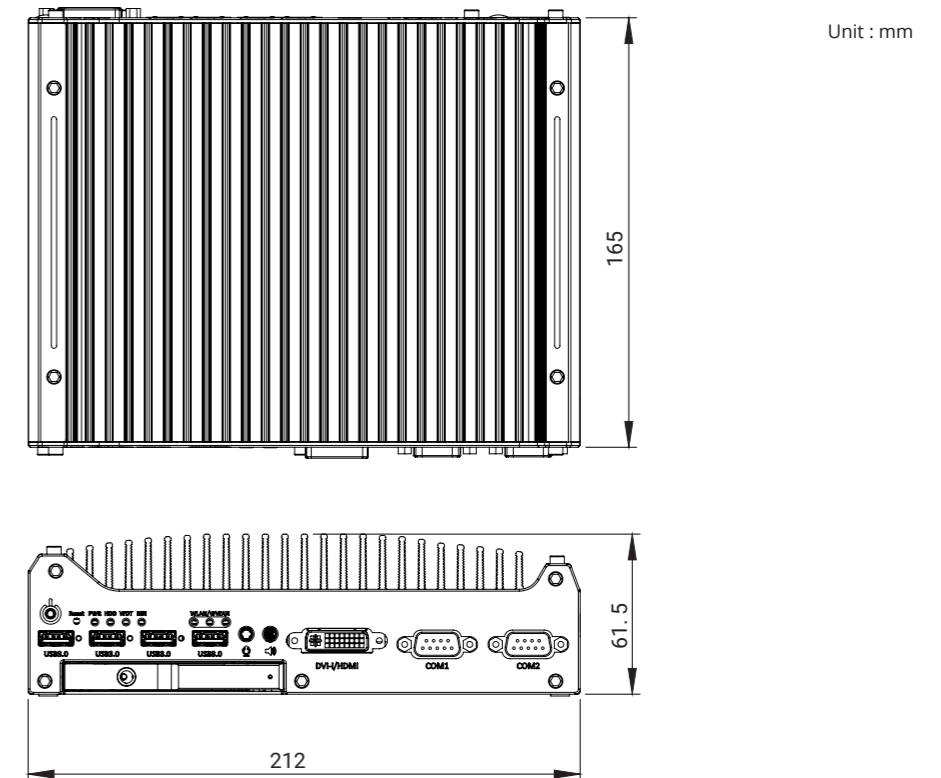

Ordering Information

Model No.	Product Description
Nuvo-3100VTC	Intel® 3rd-Gen Core™ i fanless in-vehicle controller with 4x IEEE 802.3at PoE+ ports and dual-drives RAID
Nuvo-3110VTC	Intel® 3rd-Gen Core™ i fanless in-vehicle controller with 4x GbE ports and dual-drives RAID

Optional Accessories

DINRAIL-31	DIN-rail mounting assembly for Nuvo-3100VTC series
PA-120W-OW	120W AC/DC power adapter 20V/6A; 18AWG/120cm; cord end terminals for terminal block, operating temperature : -30 to 70 °C.

Nuvo-2510VTC Series

Intel® Atom™ Bay Trail In-vehicle Fanless Computer with 2x IEEE 802.3at PoE+ Ports



Key Features

- Intel® Atom™ Bay Trail E3845 quad-core processor
- Dual mPCIe and USIM sockets for 3G, LTE, WLAN, BT or GPS module
- Dual storage with 1x mSATA and 1x SATA
- Intelligent ignition power control
- 1x CAN bus port (CAN 2.0A/ CAN 2.0B compliance)
- 8 to 35V DC wide-range DC input
- Operating temperature from -25° to 70°C
- Patented damping bracket* increases stability with HDD
- E13 No. 10R-0513905



*R.O.C Patent No. M491752

Introduction

Nuvo-2510VTC is an in-vehicle fanless computer with Intel® Atom™ E3845 quad-core processor. Equipped with 2 IEEE 802.3at Gigabit Ethernet ports, Nuvo-2510VTC is capable of driving 25W GigE and PoE IP cameras with a single standard CAT-5e. Along with intelligent ignition power control and built-in CAN bus, Nuvo-2510VTC is ideal for light-weight mobile applications such as mobile NVR and mobile APNR.

Designed for in-vehicle applications, Nuvo-2510VTC supports wide-range DC input and can be powered by 12VDC or 24VDC vehicle battery. It features intelligent ignition power control with selectable on and off delay and battery voltage monitoring. Nuvo-2510VTC also supports one built-in CAN bus port with compliance to CAN 2.0A and CAN 2.0B. The CAN bus is the foundation of many different kinds of vehicles protocols.

Nuvo-2510VTC provides 2 PoE+ Gigabit Ethernet ports and 1 USB3.0 port for industry cameras and IP cameras. Besides, 4 serial ports and 3 USB2.0 ports are available. For mobile applications which require data transmission, Nuvo-2510VTC is possible to install two 3G/4G modules with USIMs in its 2 mini PCI Express (mPCIe) sockets. Nuvo-2510VTC is ideal for your versatile in-vehicle applications.

Specifications

System Core		Expansion Bus	
Processor	Intel® Atom™ Bay Trail E3845 quad-core processor (1.91 GHz, 2M cache)	Mini PCI-E	1x full-sized mini PCI Express socket with USIM socket (PCIe + USB) 1x full-sized mini PCI Express socket with external USIM socket (USB)
Graphics	Integrated Intel® HD Graphics	Power Supply	DC Input
Memory	Up to 8GB DDR3L 1333MHz SDRAM (single SO-DIMM slot)		1x 3-pin pluggable terminal block for ignition signal and 8-35V DC input
Front Panel I/O Interface		Mechanical	
PoE Port	2x IEEE 802.3at (25.5W) Gigabit Ethernet ports by Intel® I210	Dimension	205 mm (W) x 145 mm (D) x 44 mm (H)
Video Port	1x DB-15 connector for analog RGB, supporting 2560 x 1600 resolution	Weight	1.9 kg (incl. CPU, memory and HDD)
Serial Port	2x software-programmable RS-232/ 422/ 485 (COM1 & COM2)	Mounting	Patented shock-absorbing wall-mounting (standard) or DIN-rail mounting (optional)
USB	1x USB3.0 port and 3x USB2.0 ports	Environmental	
Back Panel I/O Interface		Operating Temperature	-25°C ~ 70°C with SSD, 100% CPU loading */** -10°C ~ 50°C with HDD, 100% CPU loading */**
Video Port	1x DVI-I connector with DVI-D output, supporting 2560 x 1600 resolution	Storage Temperature	-40°C ~ 85°C
Audio	1x Mic-in and 1x speaker-out	Humidity	10%~90% , non-condensing
Series Port	2x RS-232 (COM3 & COM4)	Vibration	Operating, 5 Grms, 5-500 Hz, 3 Axes (w/ SSD, according to IEC60068-2-64)
CAN bus	1x DB-9 connector for CAN bus communications	Shock	Operating, 50 Grms, Half-sine 11 ms Duration (w/ SSD, according to IEC60068-2-27)
Storage Interface		Certification	E-Mark for vehicle applications CE/ FCC Class A, according to EN 55022 & EN 55024
SATA HDD	1x internal SATA port for 2.5" HDD/ SSD installation		
mSATA	1x internal half-sized mSATA (SATA + USB)		

* The 100% CPU loading is applied using Passmark® BurnInTest™ v7.0. For detail testing criteria, please contact Neosys Technology
** For sub-zero operating temperature, a wide temperature HDD drive or Solid State Disk (SSD) is required.

Appearance

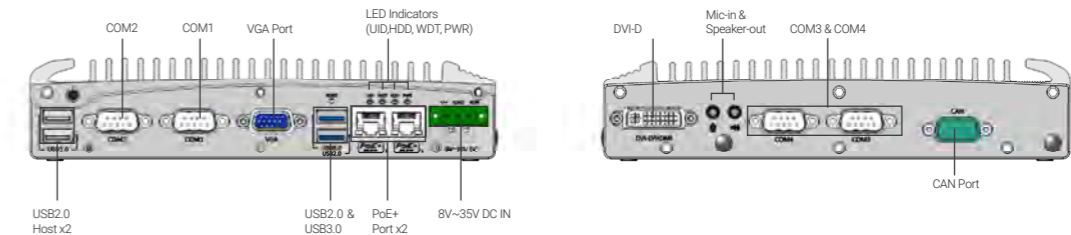

Dimensions

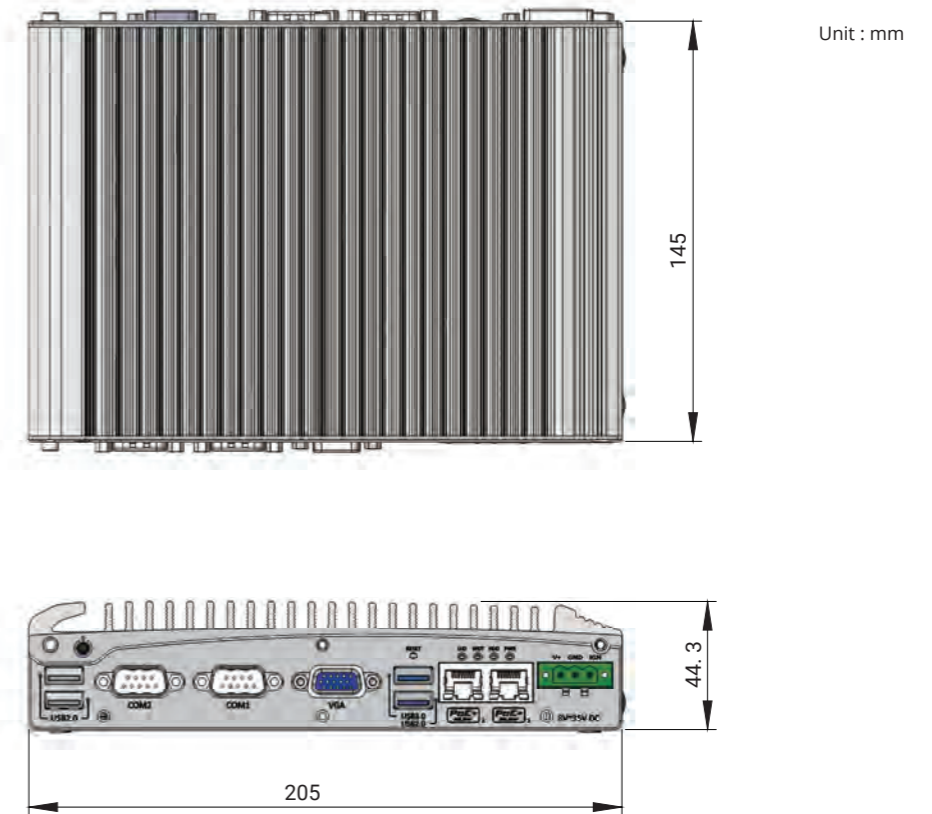

Ordering Information

Model No.	Product Description
Nuvo-2510VTC	Intel® Atom™ E3845 in-vehicle fanless computer with 2x IEEE 802.3at PoE+ ports

Optional Accessories

DINRAIL-25	DIN-rail mounting assembly for Nuvo-2510VTC series
PA-60W-OW	60W AC/DC power adapter with 12V, 5A DC output, cord end terminals for terminal block, operating temperature : -30 to 60 °C.

Nuvo-7100VTC Series

Intel® 8th-Gen Core™ i7/i5/i3 In-Vehicle Controller with 4x or 8x PoE+ Ports, DIO, CAN bus and RAID



CE FC Preliminary

Key Features

- Supports Intel® 8th-Gen Core™ i7/ i5/ i3 LGA1151 socket-type CPU
- 4x or 8x 802.3at Gigabit PoE+ ports via M12 or RJ45 connectors
- On-board CAN bus for in-vehicle communication
- 4-CH isolated DI and 4-CH isolated DO
- 2x SATA ports with one hot-swappable HDD tray, supporting RAID 0/ 1
- 3x full-size mini-PCIe sockets with SIM support
- M.2 2280 M key socket (Gen3 x4) supporting NVMe SSD or Intel® Optane™ memory
- 4x USB 3.1 Gen2 ports and 4x USB 3.1 Gen1 ports
- VGA/ DVI/ DP triple independent display, supporting 4K2K resolution
- 8~35V wide-range DC input with built-in ignition power control

Introduction

Nuvo-7100VTC is a state-of-the-art in-vehicle controller, powered by Intel® 8th-Gen Core™ i processors with up to 6-core/ 12-thread architecture that offer a significant performance improvement over previous 6th or 7th-Gen platforms for various in-vehicle applications.

Nuvo-7100VTC offers four or eight 802.3at PoE+ ports to supply 25W power to the connected device. They are implemented using RJ45 or M12 (x-coded connectors), which guarantee extremely rugged connection in shock/ vibration environments. Two more Gigabit Ethernet ports by RJ45 are available for data communication. You can also utilize four internal mini-PCIe sockets with corresponding modules for 3G/ 4G/ WIFI/ GPS communication.

In addition, Nuvo-7100VTC integrates CAN bus for in-vehicle communication, and isolated DIO for sensor/ actuator control. Combining ignition power control and dual-drive RAID storage, Nuvo-7100VTC is the perfect solution for all your in-vehicle application needs.

Specifications

System Core	Storage Interface
Processor Supporting Intel® 8th-Gen Coffee Lake CPU (LGA1151 socket, 35W/ 65W TDP) - Intel® Core™ i7-8700/ i7-8700T - Intel® Core™ i5-8500/ i5-8500T - Intel® Core™ i3-8100/ i3-8100T - Intel® Pentium® G5400/ G5400T - Intel® Celeron® G4900/ G4900T	M.2 1x M.2 2280 M key socket (PCIe Gen3 x4) for NVMe SSD or Intel® Optane™ memory installation
Chipset Intel® Q370 Platform Controller Hub	Expansion Bus 1x full-size mini PCI Express socket with internal SIM socket (mux with mSATA) 2x full-size mini-PCIe sockets (USB signals only) with internal SIM sockets
Graphics Integrated Intel® HD Graphics 630	M.2 1x M.2 2242 B key socket with dual front-accessible SIM sockets, supporting dual SIM mode with selected M.2 LTE module
Memory Up to 32 GB DDR4 2666/ 2400 SDRAM (two SODIMM slots)	Power Supply DC Input 1x 3-pin pluggable terminal block for 8~35V DC input (IGN/ GND/ V+)
AMT Supports AMT 12.0	Remote Ctrl. & Status Output 1x 3-pin pluggable terminal block for remote control and PWR LED output
TPM Supports TPM 2.0	Mechanical Dimension 240 mm (W) x 225 mm (D) x 79 mm (H)
I/O Interface Ethernet 2x Gigabit Ethernet ports by Intel® I219 and I210 4x IEEE 802.3at (25.5W) Gigabit PoE+ ports by Intel® I210, - M12 x-coded connector (Nuvo-7100VTC); - RJ45 connector (Nuvo-7104VTC)	Weight 3.3 kg
PoE+ 8x IEEE 802.3at (25.5W) Gigabit PoE+ ports by Intel® I210 - RJ45 connector (Nuvo-7108VTC)	Mounting Neosys' patented damping bracket (standard) or optional DIN-rail mounting
CAN 1x CAN 2.0 port	Environmental Operating Temperature with 35W CPU -25°C ~ 70°C ** with 65W CPU -25°C ~ 70°C */** (configured as 35W TDP) -25°C ~ 50°C */** (configured as 65W TDP)
Isolated DIO 4x isolated DI and 4x isolated DO	Storage Temperature -40°C ~ 85°C
USB 4x USB 3.1 Gen2 (10 Gbps) ports 4x USB 3.1 Gen1 (5 Gbps) ports	Humidity 10%~90% , non-condensing
Video Port 1x VGA connector, supporting 1920 x 1200 resolution 1x DVI-D connector, supporting 1920 x 1200 resolution 1x DisplayPort connector, supporting 4096 x 2304 resolution	Vibration Operating, MIL-STD-810G, Method 514.6, Category 4
Serial Port 2x software-programmable RS-232/422/485 ports (COM1/ COM2) 2x RS-232 ports (COM3/ COM4)	Shock Operating, MIL-STD-810G, Method 516.6, Procedure I, Table 516.6-II
Audio 1x Mic-in and 1x speaker-out	EMC CE/FCC Class A, according to EN 55032 & EN 55024
Storage Interface SATA HDD 1x hot-swappable HDD tray for 2.5" HDD/ SSD installation 1x Internal SATA port for 2.5" HDD/ SSD installation, supporting RAID 0/ 1	
mSATA 1x full-size mSATA port (mux with mini-PCIe)	

* For i7-8700 running at 65W mode, the highest operating temperature shall be limited to 50°C and thermal throttling may occur when sustained full-loading applied. Users can configure CPU power in BIOS to obtain higher operating temperature.
 ** For sub-zero operating temperature, a wide temperature HDD or Solid State Disk (SSD) is required.

Appearance

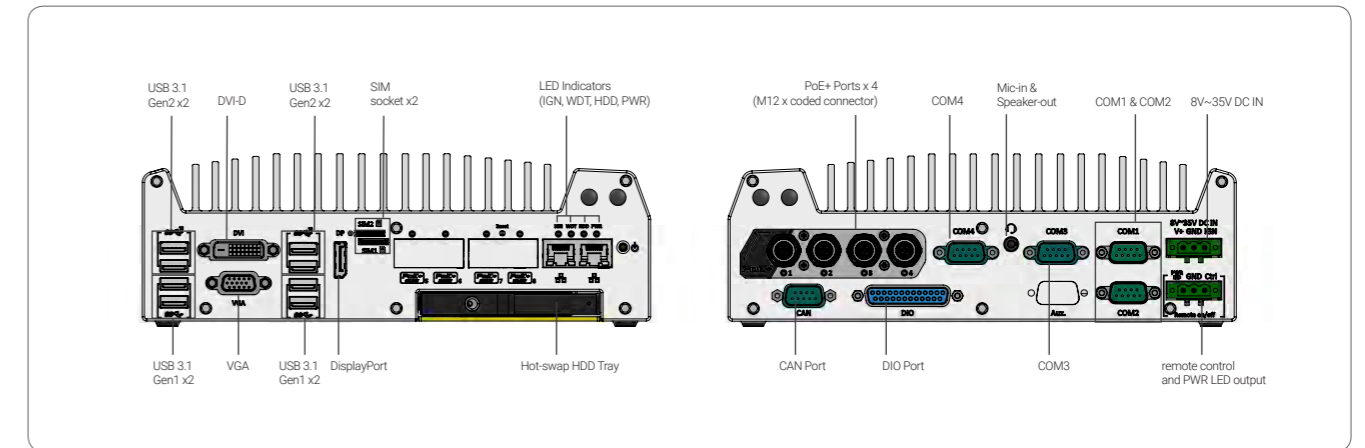

Dimensions

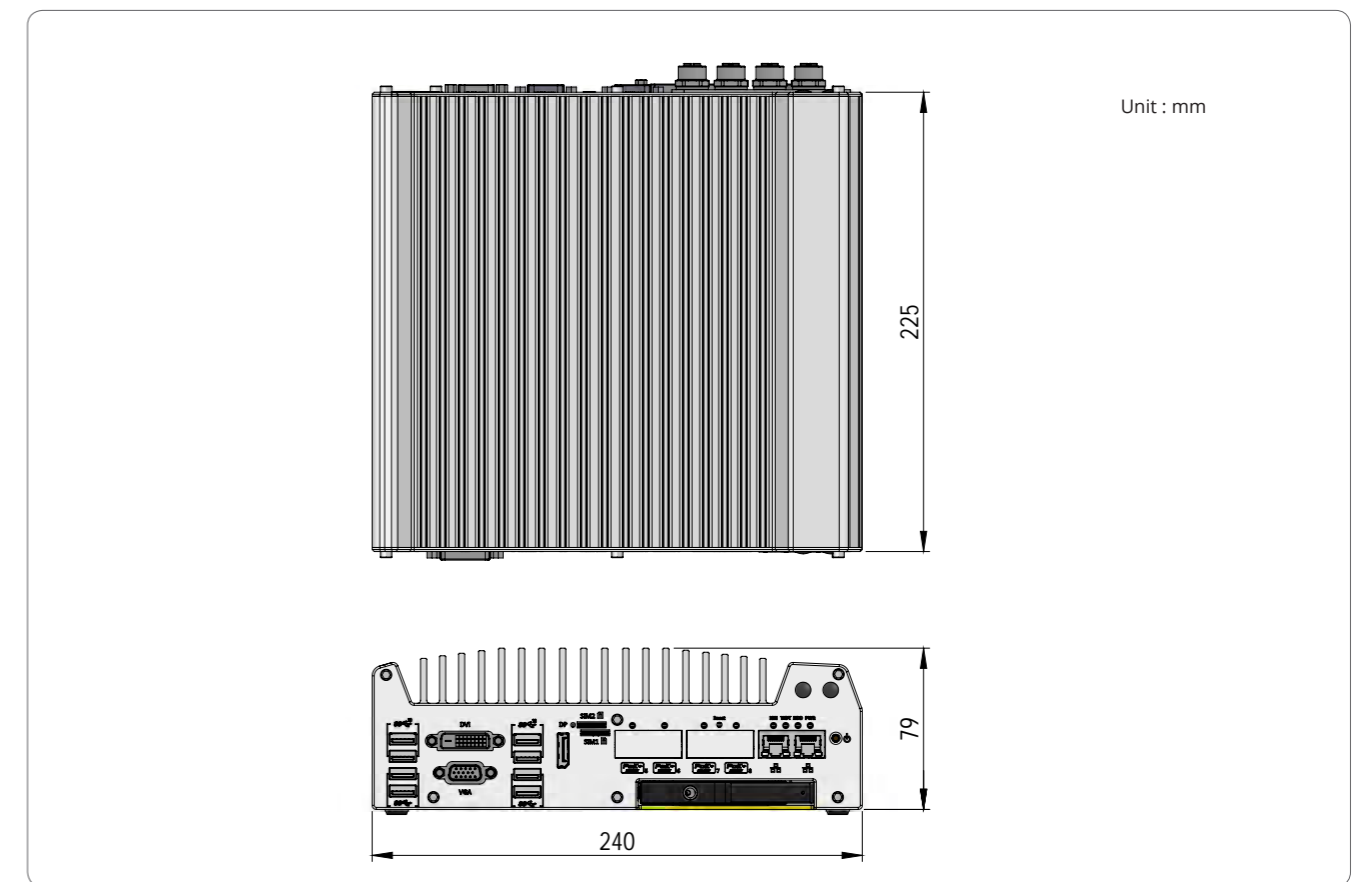

Ordering Information

Model No.	Product Description
Nuvo-7100VTC	Intel® 8th-Gen Core™ i in-vehicle controller with 4x M12 PoE+ Ports, DIO, CAN bus and RAID
Nuvo-7104VTC	Intel® 8th-Gen Core™ i in-vehicle controller with 4x RJ45 PoE+ Ports, DIO, CAN bus and RAID
Nuvo-7108VTC	Intel® 8th-Gen Core™ i in-vehicle controller with 8x RJ45 PoE+ Ports, DIO, CAN bus and RAID

Optional Accessories

C-M12-RJ45-LAN-5M	M12(8-pole-X-coded) to RJ45, CAT6, length : 5M
C-M12-RJ45-LAN-10M	M12(8-pole-X-coded) to RJ45, CAT6, length : 10M
PA-120W-OW	120W AC/DC power adapter 20V/6A; 18AWG/120cm; cord end terminals for terminal block, operating temperature : -30 to 70 °C.

Nuvo-5608VR Series

Intel® 6th-Gen Core™ i7/i5 Fanless Surveillance System with 8x PoE+, DIO, CAN bus and 2x 3.5" HDD Accommodation Supporting RAID 0/1



Key Features

- Supports Intel® 6th-Gen Core™ i7/ i5/ i3 LGA1151 socket-type processor
- 8x 802.3at PoE+ ports and 2x GbE ports
- 2x 3.5" HDD accommodation, support RAID 0/1 with over 24 TB capacity
- Dedicated HDD heat-spreader for optimized thermal performance
- 4x full-size mini-PCIe sockets with SIM support
- 4-CH isolated DI and 4-CH isolated DO
- 1x CAN 2.0 port
- 8~35V wide-range DC input with built-in ignition power control
- Patented damping brackets* to withstand 1 Grms Vibration

*R.O.C Patent No. M491752

Introduction

Nuvo-5608VR is Neosys' latest fanless surveillance system designed for real-time video analysis and streaming. It incorporates 6th-Gen Core™ i CPU, IP camera connectivity and massive storage capacity for emerging intelligent surveillance/ security applications.

Featuring eight Gigabit PoE+ ports, Nuvo-5608VR provides sufficient bandwidth to collect high-definition video streams from IP cameras, while its 6th-Gen Core™ i7 CPU is capable of performing real-time video analytics. It accommodates two 3.5" hard drives with RAID 0/ 1 configuration to support more than 24 TB storage capacity for recording 8-CH, 1080p@H.264 video for over 3 months.

Neosys' patented damping-bracket is shipped with Nuvo-5608VR to protect the system against vibration in harsh environmental conditions.

Being a rugged surveillance platform, Nuvo-5608VR is equipped with dedicated HDD heat-spreaders to maintain adequate HDD operating temperature and along with extra features such as DIO, CAN bus and ignition control, Nuvo-5608VR is the perfect fit for both stationary and mobile surveillance applications.

Specifications

System Core	Expansion Bus
Processor Supports 6th-Gen Intel® Core™ i7/ i5/ i3 LGA1151 CPU Intel® Core™ i7-6700 (8M Cache, 3.4/ 4.0 GHz, 65W TDP) Intel® Core™ i5-6500 (6M Cache, 3.2/ 3.6 GHz, 65W TDP) Intel® Core™ i3-6100 (3M Cache, 3.7 GHz, 51W TDP) Intel® Core™ i7-6700TE (8M Cache, 2.4/ 3.4 GHz, 35W TDP) Intel® Core™ i5-6500TE (6M Cache, 2.3/ 3.3 GHz, 35W TDP) Intel® Core™ i3-6100TE (4M Cache, 2.7 GHz, 35W TDP)	1x full-size mini-PCIe socket with panel-accessible SIM socket 1x full-size mini-PCIe socket with internal SIM socket (mux with mSATA) 2x full-size mini-PCIe sockets (USB signals only) with internal SIM sockets
Chipset Intel® Q170 Platform Controller Hub Graphics Integrated Intel® HD Graphics 530 Memory Up to 32 GB DDR4-2133 SDRAM (two SO-DIMM slots) AMT Supports AMT 11.0 TPM Supports TPM 2.0	Power Supply DC Input 1x 3-pin pluggable terminal block for 8~35VDC DC input Remote Ctrl. & Status Output 1x 10-pin (2x5) wafer connector for remote on/off control and status LED output
I/O Interface Ethernet port 2x Gigabit Ethernet ports by Intel® I219 and I210 PoE+ 8x IEEE 802.3at (25.5W) Gigabit PoE+ ports by Intel® I210, 120W total power budget* USB 4x USB3.0 ports via native XHCI controller 4x USB 2.0 ports Video Port 1x stacked VGA + DVI-D connector 2x DisplayPort connectors, supporting 4K2K resolution Serial Port 2x software-programmable RS-232/ 422/ 485 ports (COM1 & COM3) 1x RS-232 port (COM2) Isolated DIO 4x isolated DI and 4x isolated DO CAN 1x CAN 2.0 port Audio 1x Mic-in and 1x speaker-out	Mechanical Dimension 240 mm (W) x 225 mm (D) x 98 mm (H) Weight 3.5 kg Mounting Neosys' patented damping bracket
Storage Interface SATA HDD 2x internal SATA port for 3.5" HDD installation, supporting RAID 0/ 1 mSATA 1x full-size mSATA port (mux with mini-PCIe)	Environmental Operating Temperature -25°C ~ 70°C (with mSATA/SSD) ** -10°C ~ 60°C (with 3.5" HDD) **/** Storage Temperature -40°C ~ 85°C Humidity 10%~90%, non-condensing Vibration Operating, 1 Grms, 5-500 Hz, 3 Axes (w/ HDD and damping bracket installed, according to IEC60068-2-64) Shock Operating, 30 Grms, Half-sine 11 ms Duration (w/ HDD and damping bracket installed, according to IEC60068-2-27) EMC CE/ FCC Class A, according to EN 55032 & EN 55024

* The total power budget for Nuvo-5608VR is related to input voltage. 120W total budget is available with 24 VDC input. When 12 VDC input is applied, the total power budget is limited to 100W.
 ** Operating temperature is verified with 100% CPU loading and 100% HDD loading applied using Passmark® BurnInTest 8.0. For detail testing criteria, please contact Neosys Technology.
 *** Depending on the HDD selected, users may encounter performance degradation in sequential disk write at low/high ambient temperature. No data integrity issue was observed in -10°C ~ 60°C operating temperature range.

Appearance

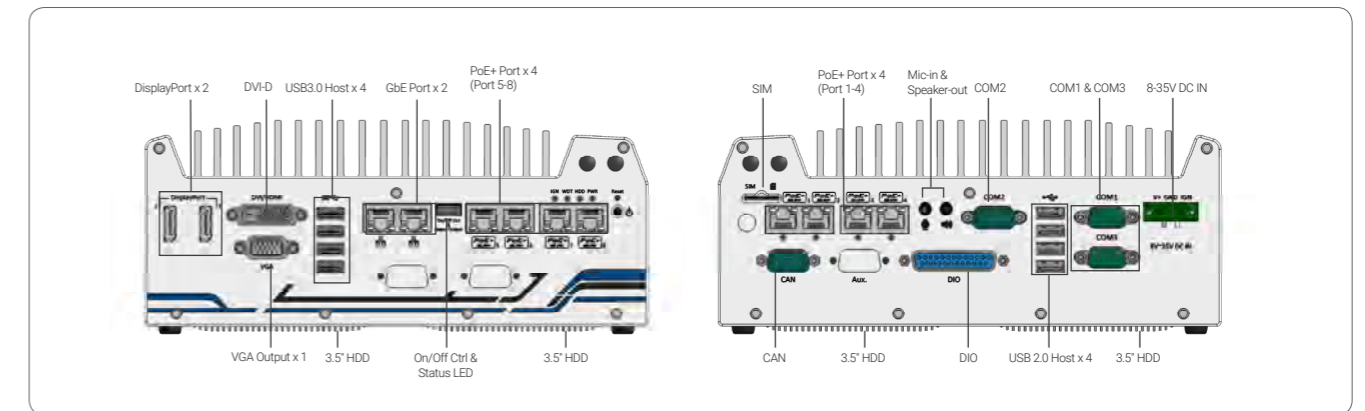

Dimensions

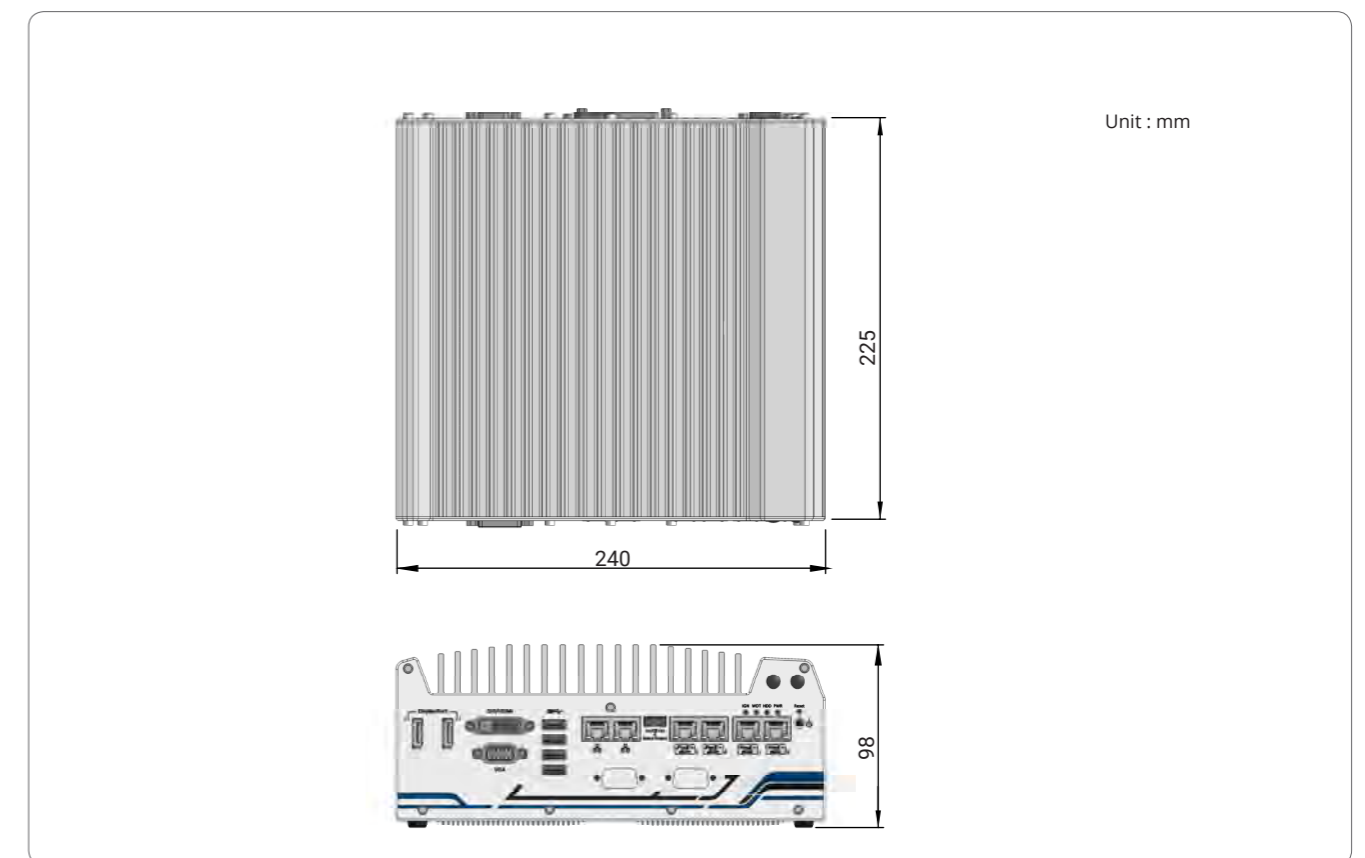

Ordering Information

Model No.	Product Description
Nuvo-5608VR	Intel® 6th-Gen Core™ i fanless surveillance system with 8x PoE+ Ports, DIO, CAN bus and 2x 3.5" HDD RAID

Optional Accessories

PA-160W-OW	160W AC/DC power adapter 20V/8A;18AWGx4C/120cm; cord end terminals for terminal block, operating temperature : -30 to 70 °C.
PA-280W-OW	280W AC/DC power adapter 24V/11.67A;16AWG/100cm; cord end terminals for terminal block, operating temperature : -30 to 60 °C.

Nuvo-3616VR Series

Intel® 3rd-Gen Core™ i7/ i5 Fanless Surveillance System Featuring 16x 802.3at PoE+ Ports and Four 2.5" Hard Drives with RAID Support



Key Features

- Intel® 3rd-Gen i7 quad-core processor
- Up to 16x IEEE 802.3at (25.5W) PoE+ ports
- Rugged, -25 °C to 60 °C fanless operation
- Four 2.5" SATA HDDs with RAID 0/ 1/ 5/ 10 support
- Patented easy-swap trays* for HDD replacement
- 8~35V wide-range DC input with built-in ignition power control
- Per-port power on/ off control for each PoE+ port

*R.O.C Patent No. M491241

Introduction

Nuvo-3616VR is a surveillance platform that features 16 PoE+ ports, i7 CPU and RAID in a compact, fanless chassis. It is designed to meet requirements of a stationary or mobile surveillance system and is capable not only for video recording but also high-end video analytic purposes. A typical surveillance system uses a NVR to connect IP cameras and record video streams on its disk array. Similar to a NVR, Nuvo-3616VR features 16 PoE+ ports and built-in disk array for video recording. Each of its 802.3at PoE+ ports can supply 25.5W to power a bullet, dome or PTZ camera. Nuvo-3616VR can also accommodate 4 hard drives with RAID support. Not your typical off-the-shelf NVR, Nuvo-3616VR comes with a quad-core i7 CPU to offer exceptional computing performance to facilitate advanced video analytics algorithms. Nuvo-3616VR inherits Neosys' proven fanless architecture to ensure true wide-temperature operation. Two of its four 2.5" drives come with Neosys' patented easy-swap trays for simple HDD/ SSD replacement. Nuvo-3616VR also features 8~35V wide-range DC input and ignition control for stationary or in-vehicle usage. Combining numerous PoE+ ports, RAID storage and superb computing power, Nuvo-3616VR opens a new page for surveillance applications!

Specifications

	Nuvo-3616VR	Nuvo-3608VR	Nuvo-3616VR	Nuvo-3608VR
System Core				
Processor	Intel® Core™ i7-3610QE (2.3/ 3.3 GHz, 6 MB cache) Intel® Core™ i5-3610ME (2.7/ 3.3 GHz, 3 MB cache)			
Chipset	Intel® QM77 Platform Controller Hub with AMT & RAID support			
Graphics	Integrated Intel® HD Graphics 4000 Controller			
Memory	Up to 16 GB DDR3 1333/ 1600 MHz SDRAM (two SO-DIMM slots)			
I/O Interface				
Ethernet	1x Gigabit Ethernet ports by Intel® 82579LM			
PoE	16x IEEE 802.3at (25.5W) PoE+ Ports with per-port power on/ off control 160W total power budget	8x IEEE 802.3at (25.5W) PoE+ Ports with per-port power on/ off control 80W total power budget		
Video Port	1x DB-15 connector for analog RGB, supporting 2048x1536 resolution 2x DVI-D connectors for DVI outputs, supporting 1920x1080 resolution			
USB	2x USB3.0 ports and 2x USB2.0 ports			
Serial Port	2x software-programmable RS-232/ 422/ 485 (COM1 & COM2)			
KB/MS	1x 6-pin mini-DIN connector for PS/2 keyboard/mouse			
Audio	1x Mic-in and 1x speaker-out			
Storage Interface				
SATA HDD	4x Internal SATA ports for 2.5" HDD/ SSD installation with RAID 0/ 1/ 5/ 10			
CFast	1x CFast socket			
Expansion Bus				
Mini PCI-E	1x internal mini PCI Express socket with USIM socket 1x internal mini PCI Express socket			
Power Supply & Ignition Control				
DC Input	1x 3-pin pluggable terminal block for 8~35V DC input (for direct DC wiring)			
Ignition Control	Ignition power control with configurable on/ off delay (V+/ GND/ IGN)			
Remote Ctrl. & Status Output	1x 10-pin (2x5) wafer connector for remote on/ off control and status LED output			
Mechanical				
Dimension	240 mm (W) x 255mm (D) x 71 mm (H)			
Weight	5.0 Kg			
Mounting	Wall-mounting			
Environmental				
Operating Temperature	-25°C ~ 60°C **			
Storage Temperature	-40°C ~ 85°C			
Humidity	10%~90% , non-condensing			
Vibration	Operating, 5 Grms, 5-500 Hz, 3 Axes (w/ SSD, according to IEC60068-2-64)			
Shock	Operating, 50 Grms, Half-sine 11 ms Duration (w/ SSD, according to IEC60068-2-27)			
EMC	CE/ FCC Class A, according to EN 55022 & EN 55024			

* 100% CPU loading is applied using Intel® Thermal Analysis Tool. For detail testing criteria, please contact Neosys Technology.
** For sub-zero operating temperature, a wide temperature HDD drive or Solid State Disk (SSD) is required.

Appearance

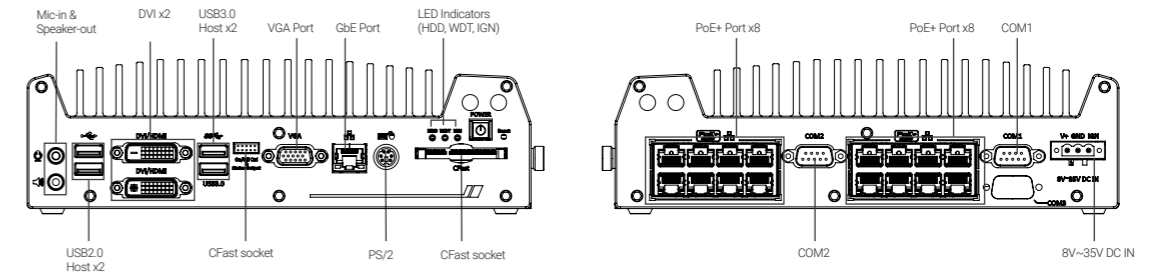

Dimensions

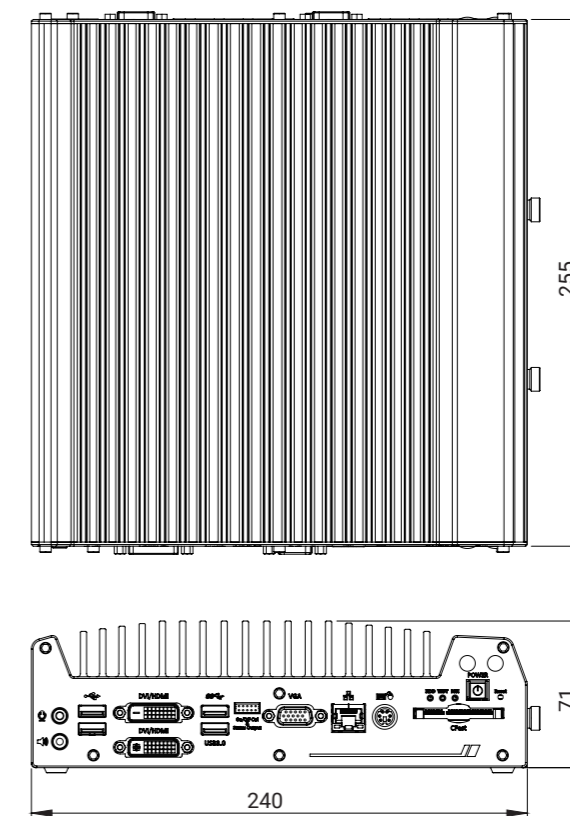

Unit : mm

Ordering Information

Model No.	Product Description
Nuvo-3616VR	Intel® 3rd-Gen Core™ i fanless surveillance system with 16x GigE PoE+ Ports and 4-drives RAID
Nuvo-3608VR	Intel® 3rd-Gen Core™ i fanless surveillance system with 8x GigE PoE+ Ports and 4-drives RAID

Optional Accessories

PA-280W-OW	280W AC/DC power adapter 24V/11.67A;16AWG/100cm; cord end terminals for terminal block, operating temperature : -30 to 60 °C.
------------	---

EDX-104 Series

5-port IEEE 802.3at PoE+ Gigabit Unmanaged Industrial Ethernet Switch with PoE+ PD and DC Dual Power Input



CE FC

Key Features

- Five 10/ 100/ 1000 Mbps Ethernet ports
- Supports IEEE 802.3at PoE+ PSE on port 2~5
- Up to 25.5 W power output on each port, total 80W power budget
- Dual power input
 - PoE+ PD (Powered Device) mode via port 1
 - 24/ 48 VDC input with power connector
- EMS level 3 protection for industrial environments
- Industrial-grade, -25°C to 70°C fanless operation
- IP50 (EDX-104J) housing

Introduction

EDX-104 series is world's first PoE+ unmanaged switch combining IEEE 802.3at PSE/ PD capability and fanless enclosure for IP protection. It offers five Gigabit Ethernet ports compliant with 802.3 (10BASE-T), 802.3u (100BASE-TX) and 802.3ab (1000BASE-T). Four of its ports support 802.3at PoE+ PSE (Power Sourcing Equipment) capability and can deliver up to 25.5W to PoE PD on each port.

The dual power mode feature is what makes EDX-104 unique. It can operate as a PoE+ PD thus you can simply power it using a Ethernet cable from a PSE. Or, when PSE is not available, you can plug-in 24/ 48V DC to power EDX-104. The option of operating in PSE or PD mode offers setup and installation flexibility.

EDX-104 series features EMS level 3 protection, wide-temperature -25°C to 70°C fanless operation and IP protection, EDX-104 is the ideal simple and rugged Ethernet switch for your industrial applications.

Specifications

PoE Standard	IEEE 802.3at PSE (port 2-5) IEEE 802.3at PD (port 1)
Ethernet Standard	IEEE 802.3 for 10BASE-T/ IEEE 802.3u for 100BASE-TX IEEE 802.3ab for 1000BASE-T/ IEEE 802.3x for flow control
# of Port	5-port, 1000/100/10 Mbps, auto-negotiation
Switch Features	MAC table size: 8192 entries Frame buffer memory: 1 Mb Jumbo frame support: 10 KB
Ethernet Connector	RJ45, PSE power out: V+/V+/V-/V- on pin 1/ 2/ 3/ 6
Power Input (PD Mode)	Via Ethernet port 1 (RJ45), total power budget for PSE: 25.5 W
Power Input (DC Mode)	24/48 VDC, via 3-pin terminal block, total power budget for PSE: 80 W
IP Rating	IP50
EMC	CE/ FCC Class A, according to EN 50022 & EN 55024 EN 50155/ 50121-3-2
EMS	EN 61000-4-2 (Level 3), EN 61000-4-3 (Level 3), EN 61000-4-4 (Level 3), EN 61000-4-5 (Level 3), EN 61000-4-6 (Level 3), EN 61000-4-8 (Level 3)
Operating Temperature	-25°C to 70°C*
Vibration	Operating, 5 Grms, 5-500 Hz, 3 Axes, according to IEC60068-2-64
Shock	Operating, 50 Grms, Half-sine 11 ms Duration, according to IEC60068-2-27
Dimension	40 mm (W) x 92 mm (D) x139 mm (H)
IP Rating	0.5kg
Mounting	DIN-rail mounting

Appearance

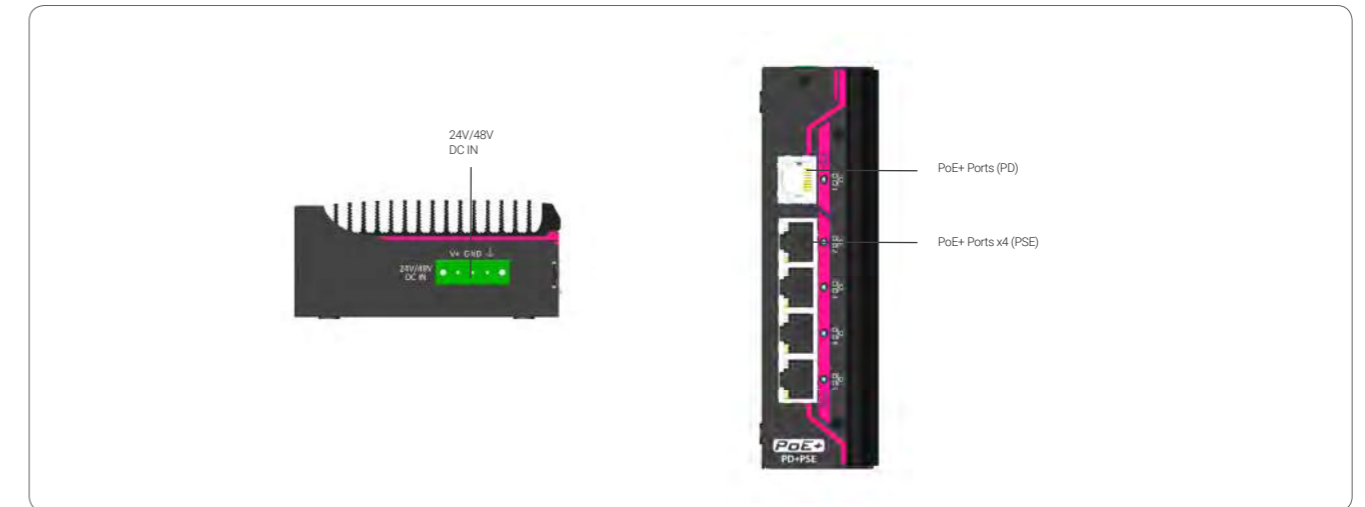

Dimensions

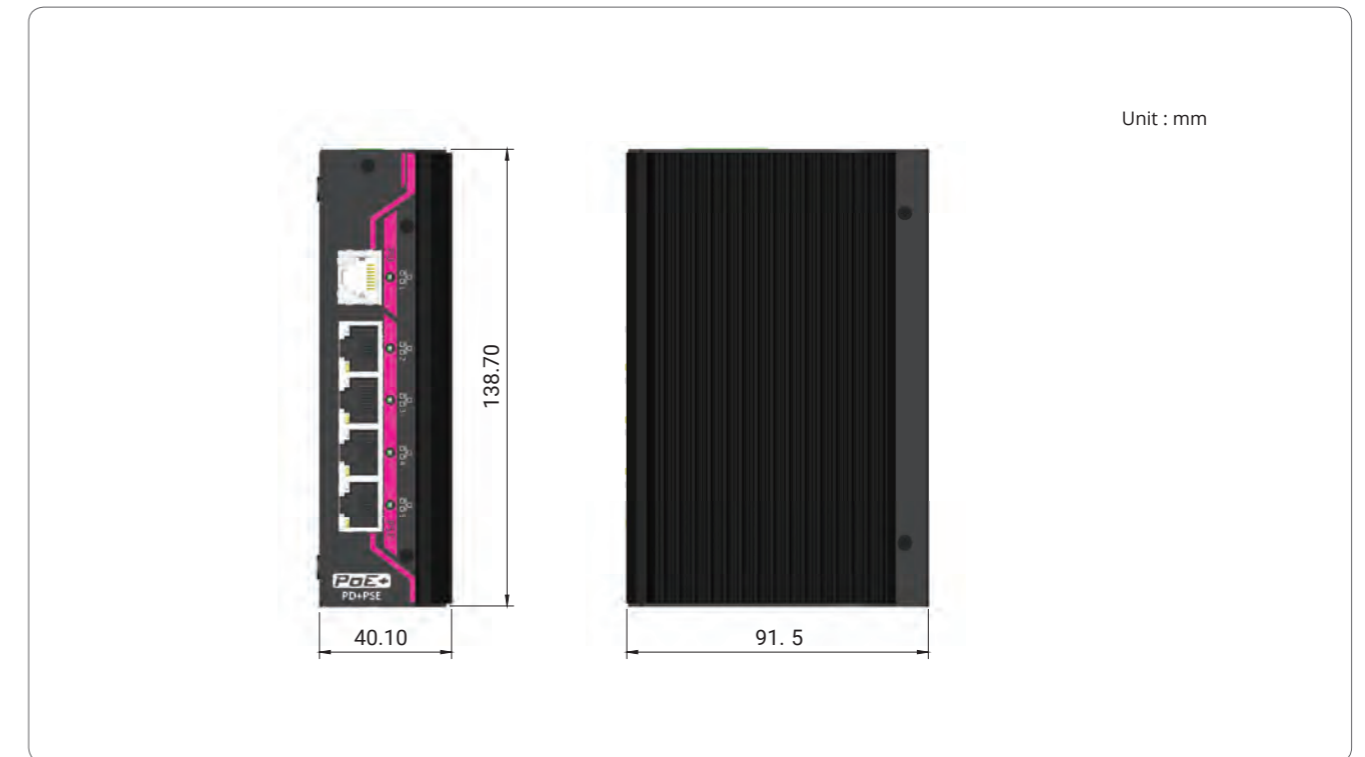

Ordering Information

Model No.	Product Description
EDX-104J	5-port IEEE 802.3at PoE+ unmanaged Gigabit Ethernet switch with PD/DC dual power mode, RJ45 connector and IP50 housing

Optional Accessories

PA-280W-OW	280W AC/DC power adapter 24V/11.67A;16AWG/100cm; cord end terminals for terminal block, operating temperature : -30 to 60 °C.
------------	---

Nuvo-7160GC Series

Ruggedized GPU-Computing Platform Supporting 120W NVIDIA® GPU and Intel® 8th-Gen Core™ Processor



CE FC

Key Features

- Supports NVIDIA® GPU graphics card up to 120W TDP
- Patented thermal design to allow -25°C to 60°C wide-temperature operation
- Intel® 8th-Gen Core™ hexa-core 35W/ 65W LGA1151 CPU
- 6x GigE ports, supporting 9.5 KB jumbo frame
- M.2 2280 M key socket (Gen3 x4) supporting NVMe SSD or Intel® Optane™ memory
- 4x USB 3.1 Gen2 ports and 4x USB 3.1 Gen1 ports
- Accommodates two 2.5" SATA HDD/ SSD with RAID 0/ 1 support
- Compatible with MeziO™ interface for function expansion
- Patented ventilation design* for graphics card

*R.O.C Patent No. M534371/ M456527

Introduction

Nuvo-7160GC is a ruggedized GPU-aided edge computer designed for modern machine learning applications such as autonomous driving, facial recognition and machine vision. It supports up to a 120W GPU, delivering 4-6 TFLOPS computing power for inference, as well as Intel® 8th-Gen Core™ 6-core/ 12-thread CPU, offering up to 50% CPU performance enhancement over previous generations.

Thanks to Neosys' patented Cassette design and ingenious ventilation mechanism, Nuvo-7160GC can effectively dissipate the heat generated by the GPU. By introducing the guided airflow from intake to exhaust with powerful fans featuring smart fan control, it allows a 120W GPU to operate at 60°C ambient temperature under 100% GPU loading.

Nuvo-7160GC incorporates rich I/O functions such as USB 3.1 Gen2/ Gen1, GbE, COM and MeziO™ interface in its restricted footprint. It also leverages cutting-edge M.2 NVMe SSD technology for over 2000MB/s disk read/ write speed or Intel® Optane™ memory for the ultimate system acceleration. Neosys Nuvo-7160GC is the ideal solution for emerging edge computing by combining exceptional CPU and GPU performances.

Specifications

System Core	
Processor	Supporting Intel® 8th-Gen Coffee Lake CPU (LGA1151 socket, 35W/ 65W TDP) - Intel® Core™ i7-8700/ i7-8700T - Intel® Core™ i5-8500/ i5-8500T - Intel® Core™ i3-8100/ i3-8100T - Intel® Pentium® G5400/ G5400T - Intel® Celeron® G4900/ G4900T
Chipset	Intel® Q370 Platform Controller Hub
Graphics	Integrated Intel® UHD Graphics 630
Memory	Up to 32 GB DDR4 2666/ 2400 SDRAM (two SODIMM slots)
AMT	Supports AMT 12.0
TPM	Supports TPM 2.0
I/O Interface	
Ethernet	6x Gigabit Ethernet ports by i219 and 5x i210
PoE+	Optional IEEE 802.3at PoE+ PSE for Port 3 ~ Port 6 100 W total power budget
USB	4x USB 3.1 Gen2 (10 Gbps) ports 4x USB 3.1 Gen1 (5 Gbps) ports
Video Port (Integrated Graphics)	1x VGA connector, supporting 1920 x 1200 resolution 1x DVI-D connector, supporting 1920 x 1200 resolution 1x DisplayPort connector, supporting 4096 x 2304 resolution
Serial Port	2x software-programmable RS-232/422/485 ports (COM1/ COM2) 2x RS-232 ports (COM3/ COM4)
Audio	1x 3.5 mm jack for mic-in and speaker-out
Storage Interface	
SATA HDD	2x internal SATA port for 2.5" HDD/ SSD installation, supporting RAID 0/ 1
M.2	1x M.2 2280 M key socket (PCIe Gen3 x4) for NVMe SSD or Intel® Optane™ memory installation
mSATA	1x full-size mSATA port (mux with mini-PCIe)
Internal Expansion Bus	
PCI/PCI Express	1x PCIe x16 slot@Gen3, 16-lanes PCIe signals in Cassette for installing an NVIDIA® graphics card up to 120W TDP (Max. graphics card dimension is 188 mm(L) x 121 mm(W), dual slot allocation)
Mini PCI Express	1x full-size mini PCI Express socket with internal SIM socket (mux with mSATA)
M.2	1x M.2 2242 B key socket with dual front-accessible SIM sockets, supporting dual SIM mode with selected M.2 LTE module
Expandable I/O	1x MeziO™ expansion port for Neosys MeziO™ modules
Power Supply	
DC Input	1x 3-pin pluggable terminal block for 8-35VDC DC input
Remote Ctrl. & LED Output	1x 3-pin pluggable terminal block for remote control and PWR LED output
Mechanical	
Dimension	240 mm (W) x 225 mm (D) x 111 mm (H)
Weight	4.5 Kg (including CPU, GPU, memory and HDD)
Mounting	Wall-mounting (standard) or DIN-Rail mounting (optional)
Environmental	
Operating Temperature	With 35W CPU and 120W GPU -25°C ~ 60°C ** With 65W CPU and 120W GPU -25°C ~ 60°C **/*** (configured as 35W TDP) -25°C ~ 50°C **/*** (configured as 65W TDP)
Storage Temperature	-40°C ~ 85°C
Humidity	10%~90% , non-condensing
Vibration	Operating, MIL-STD-810G, Method 514.6, Category 4
Shock	Operating, MIL-STD-810G, Method 516.6, Procedure I, functional shock=50g
EMC	CE/FCC Class A, according to EN 55032 & EN 55024

** For i7-8700 running at 65W mode, the highest operating temperature shall be limited to 50°C and thermal throttling may occur when sustained full-loading applied. Users can configure CPU power in BIOS to obtain higher operating temperature.

*** For sub-zero operating temperature, a wide temperature HDD or Solid State Disk (SSD) is required.

Appearance

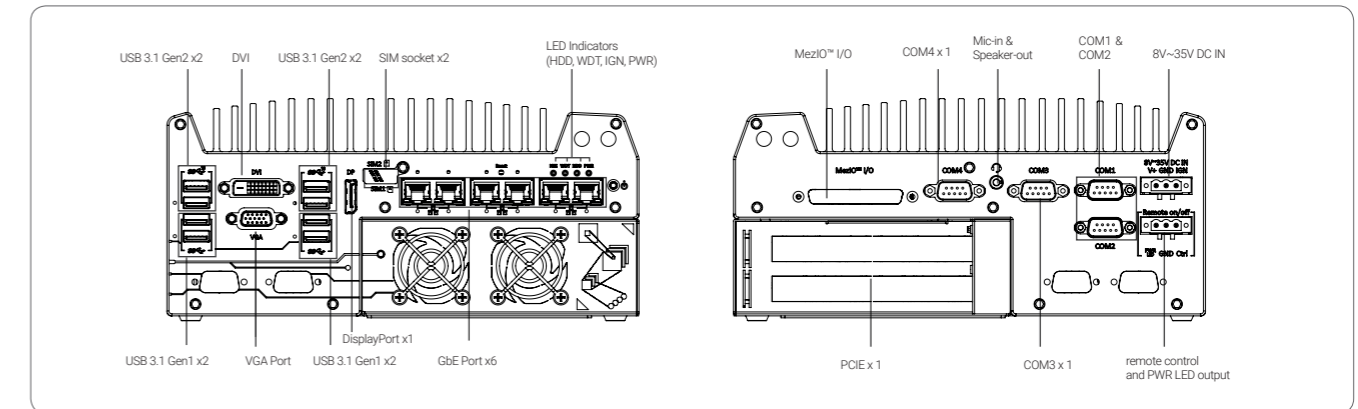

Dimensions

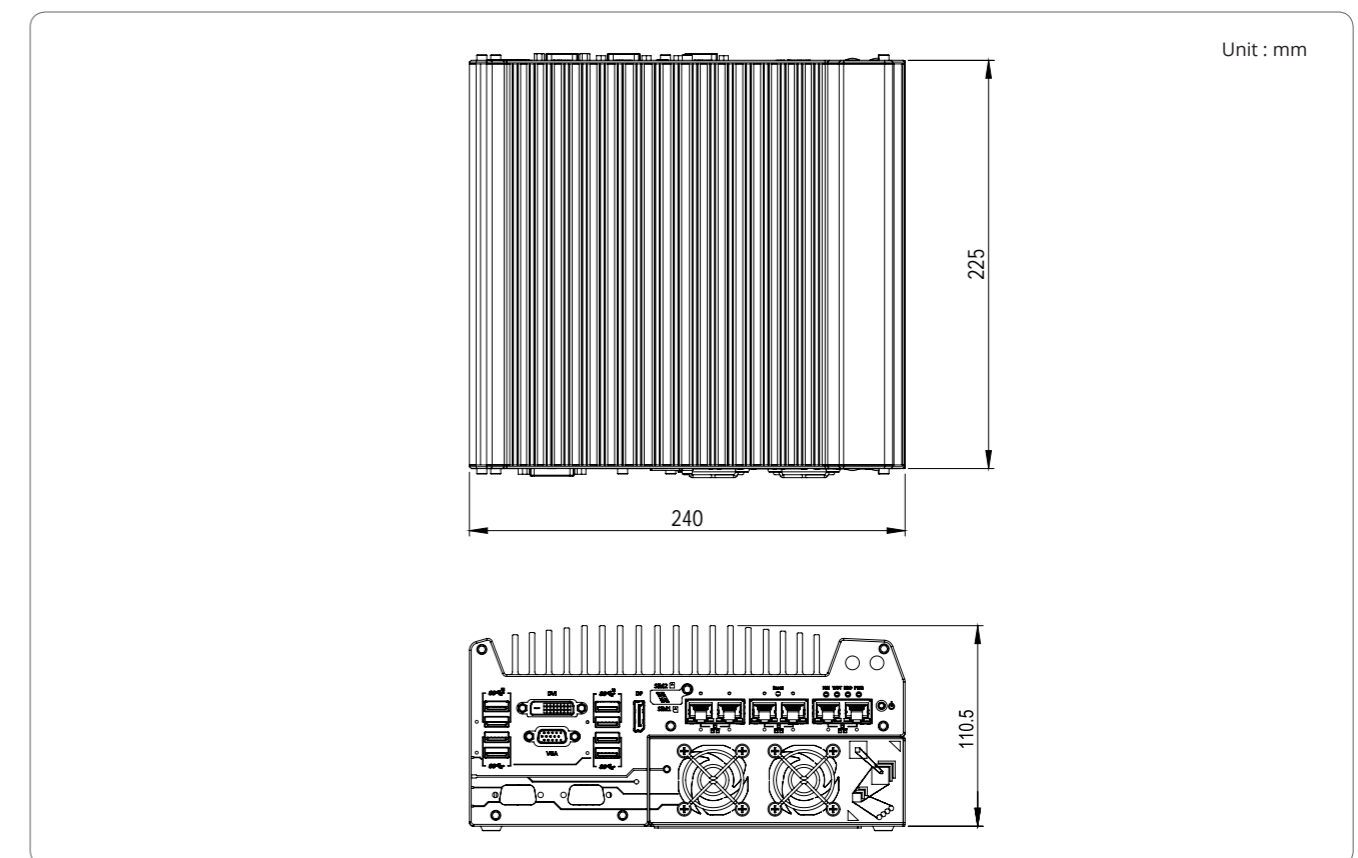

Ordering Information

Model No.	Product Description
Nuvo-7160GC	Intel® 8th-Gen Core™ GPU-computing platform with 6x GbE and MeziO™, supporting selected NVIDIA® 120W GPU
	Option of 802.3at PoE+ for GbE ports 3 ~ 6

Optional Accessories

PA-280W-OW	280W AC/DC power adapter 24V/11.67A; 16AWG/100cm; Cord end terminals for terminal block, operating temperature : -30°C to 60°C.
Damping bracket	Neosys' patented damping bracket assembly for Nuvo-7160GC

Nuvo-6108GC-IGN

Industrial-grade in-vehicle GPU-computing Platform with 250W NVIDIA® GPU and Intel® Xeon® E3 v5 and 6th-Gen Core™ Processor



CE FC

Key Features

- Supports Intel® Xeon® E3 v5 or 6th-Gen Core™ i7/ i5 LGA1151 CPU
- Supports NVIDIA® GPU (up to 250W TDP)
- Patented thermal design for -25 °C to 60 °C rugged operation*
- Two x8, Gen3 PCIe slots for add-on cards
- Dual GbE ports and four USB3.0 ports
- Three 2.5" SATA hard drives with RAID 0/ 1/ 5 support
- Patented easy-swap trays* for HDD replacement
- Automatic temperature sensing and fan control
- Patented damping brackets* to withstand 1 Grms vibration
- Built-in ignition control

*R.O.C Patent No. M534371 / M491241 / M491752

Introduction

Nuvo-6108GC series is world's first industrial-grade GPU computer supporting high-end graphics cards. It's designed to fuel emerging GPU-accelerated applications, such as artificial intelligence, VR, autonomous driving and CUDA computing by accommodating 250W NVIDIA® GPU.

Leveraging Intel® C236 chipset, Nuvo-6108GC series supports Xeon® E3 v5 or 6th-Gen Core™ i7/ i5 CPU with up to 32 GB ECC/ non-ECC DDR4 memory. It incorporates general computer I/O like Gigabit Ethernet, USB3.0 and serial ports. In addition to the x16 PCIe port for GPU installation, Nuvo-6108GC series also has two x8 PCIe slots so you can install additional high performance expansion card with high bandwidths for data collections/ analytics and communication.

Nuvo-6108GC series comes with sophisticated power design to handle heavy power consumption and power transient of a 250W GPU. Furthermore, to have reliable GPU performance for industrial environments, Nuvo-6108GC series utilizes Neosys' patented design*, a tuned cold air intake to effectively dissipate the heat generated by GPU. This unique design guarantees operation at 60°C under 100% GPU loading, making Nuvo-6108GC series extremely reliable for demanding field applications.

The new model Nuvo-6108GC-IGN features built-in ignition power control and two of its three 2.5" drives come with Neosys' patented easy-swap trays for simple HDD/ SSD replacement.

Specifications

System Core		Expansion Bus/ Internal I/O Interface		
Processor	Intel® Xeon® E3 v5 or 6th-Gen Core™ LGA1151 CPU	PCI Express	1x PCIe x16 slot @ Gen3, 16-lanes PCIe signals for GPU	
	- Intel® Xeon® Processor E3-1275 v5 (8M Cache, 3.6/ 4.0 GHz)		2x PCIe x8 slot @ Gen3, 4-lanes PCIe signals	
	- Intel® Xeon® Processor E3-1268L v5 (8M Cache, 2.4/ 3.4 GHz)	M.2	1x M.2 B key socket for 3G/4G options with SIM socket	
	- Intel® Core™ i7-6700 (8M Cache, 3.4/ 4.0 GHz)		mini-PCIe	1x full-size mini PCI Express socket
	- Intel® Core™ i5-6500 (6M Cache, 3.2/ 3.6 GHz)			Remote Ctrl. & Status Output
- Intel® Core™ i7-6700TE (8M Cache, 2.4/ 3.4 GHz)	- Intel® Core™ i5-6500TE (6M Cache, 2.3/ 3.3 GHz)	Power Supply	DC Input	
Chipset	Intel® C236 Platform Controller Hub		Input Connector	3-pin pluggable terminal block for DC input (IGN/ GND/ V+)
Graphics	Independent GPU via x16 PEG port, or integrated Intel® HD 530 controller	Mechanical	Dimension	178 mm (W) x 360 mm (D) x 174 mm (H)
Memory	Up to 32 GB ECC/ non-ECC DDR4-2133	Weight	4.7 kg (incl. CPU, GPU, memory and HDD)	
I/O Interface		Mounting	Wall-mounting with damping brackets	
Ethernet	1x Gigabit Ethernet port by Intel® I219-LM 1x Gigabit Ethernet port by Intel® I210-IT	Environmental	Operating Temperature	-25°C ~ 60°C with 100% CPU/ GPU loading **/***
Native Video Port	2x DVI-D connectors for DVI outputs, supporting 1920x1200 resolution	Storage Temperature	-40°C ~ 85°C	
Serial Port	2x software-programmable RS-232/ 422/ 485 ports	Humidity	10%~90%, non-condensing	
USB	4x USB3.0 ports	Vibration	Operating, 1 Grms, 5-500 Hz, 3 Axes (w/ GPU, fan and HDD), according to IEC60068-2-64)	
Audio	1x Speaker-out	EMC	CE/ FCC Class A, according to EN 55022, EN 55024 & EN 55032	
Storage Interface				
SATA	2x easy-swap HDD trays for 2.5" HDD/ SSD installation 1x Internal SATA port for 2.5" HDD/ SSD installation, supporting RAID 0/ 1/ 5			

** The CPU and GPU loading are applied using Passmark® BurnInTest 8.0 with 35 TDP CPU. Operating Temperature degrades with higher TDP CPU. For detail testing criteria, please contact Neosys Technology

*** For sub-zero operating temperature, a wide temperature HDD drive or Solid State Disk (SSD) is required.

Appearance

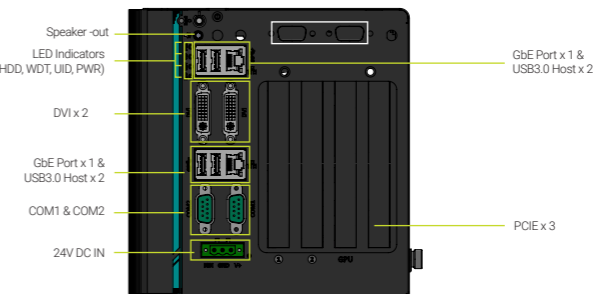

Dimensions

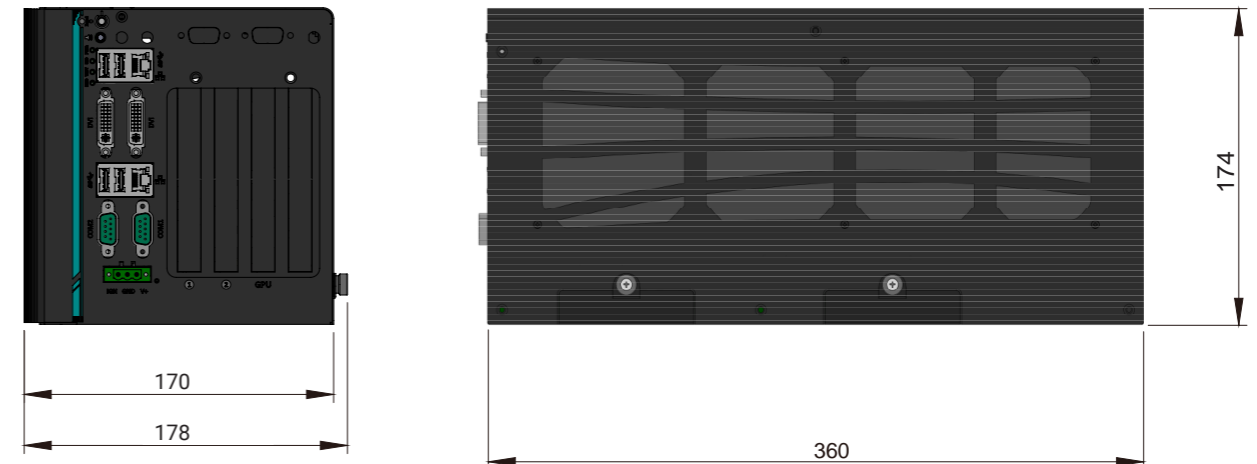

Ordering Information

Model No.	Product Description
Nuvo-6108GC-IGN	Industrial-grade GPU computing platform supporting up to 250W NVIDIA® graphics card, Intel® Xeon® E3 v5 and 6th-Gen Core™ processor with built-in ignition control and 2x easy-swap trays

Optional Accessories

PA-280W-OW	280W AC/DC power adapter 24V/11.67A; 16AWG/100cm; Cord end terminals for terminal block, operating temperature : -30 to 60 °C.
PA-480W-DIN	480W AC-DC power adapter DIN-rail mount, 24V 20A, 90~264VAC/127~370VDC, terminal block, -20 to 70°C, Meanwell SDR-480-24

Nuvo-6108GC

Industrial-grade GPU Computing Platform Supporting 250W NVIDIA® GPU and Intel® Xeon® E3 v5 or 6th-Gen Core™ Processor



CE FC

Key Features

- Supports Intel® Xeon® E3 v5 or 6th-Gen Core™ i7/ i5 LGA1151 CPU
- Supports NVIDIA® GPU (up to 250W TDP)
- Patented thermal design for -25 °C to 60 °C rugged operation*
- Two x8, Gen3 PCIe slots for add-on cards
- Dual GbE ports and four USB3.0 ports
- Four 2.5" SATA hard drives with RAID 0/ 1/ 5/ 10 support
- Automatic temperature sensing and fan control
- Patented damping brackets* to withstand 1 Grms vibration

*R.O.C Patent No. M534371 / M491752

Introduction

Nuvo-6108GC is world's first industrial-grade GPU computer supporting high-end graphics cards. It's designed to fuel emerging GPU-accelerated applications, such as artificial intelligence, VR, autonomous driving and CUDA computing by accommodating 250W NVIDIA® GPU.

Leveraging Intel® C236 chipset, Nuvo-6108GC supports Xeon® E3 v5 or 6th-Gen Core™ i7/ i5 CPU with up to 32 GB ECC/ non-ECC DDR4 memory. It incorporates general computer I/O like Gigabit Ethernet, USB3.0 and serial ports. In addition to the x16 PCIe port for GPU installation, Nuvo-6108GC also has two x8 PCIe slots so you can install additional high performance expansion card with high bandwidths for data collections/ analytics and communication.

Nuvo-6108GC comes with sophisticated power design to handle heavy power consumption and power transient of a 250W GPU. Furthermore, to have reliable GPU performance for industrial environments, Nuvo-6108GC utilizes Neousys' patented design*, a tuned cold air intake to effectively dissipate the heat generated by GPU. This unique design guarantees operation at 60°C under 100% GPU loading, making Nuvo-6108GC extremely reliable for demanding field applications.

Specifications

System Core		Expansion Bus/ Internal I/O Interface	
Processor	Intel® Xeon® E3 v5 or 6th-Gen Core™ LGA1151 CPU	PCI Express	1x PCIe x16 slot @ Gen3, 16-lanes PCIe signals for GPU 2x PCIe x8 slot @ Gen3, 4-lanes PCIe signals
	- Intel® Xeon® Processor E3-1275 v5 (8M Cache, 3.6/ 4.0 GHz)	M.2	1x M.2 B key socket for 3G/4G options with SIM socket
	- Intel® Xeon® Processor E3-1268L v5 (8M Cache, 2.4/ 3.4 GHz)	mini-PCIe	1x full-size mini PCI Express socket
	- Intel® Core™ i7-6700 (8M Cache, 3.4/ 4.0 GHz)	Remote Ctrl. & Status Output	1x 2x6-pin 2.0mm pin-header connector for remote on/ off control and status LED output
	- Intel® Core™ i5-6500 (6M Cache, 3.2/ 3.6 GHz)	Power Supply	DC Input
- Intel® Core™ i7-6700TE (8M Cache, 2.4/ 3.4 GHz)	- Intel® Core™ i5-6500TE (6M Cache, 2.3/ 3.3 GHz)	Remote Ctrl. & Status Output	1x3-pin pluggable terminal block for remote on/ off control
Chipset	Intel® C236 Platform Controller Hub	Mechanical	
Graphics	Independent GPU via x16 PEG port, or integrated Intel® HD 530 controller	Dimension	164 mm (W) x 360 mm (D) x 174 mm (H)
Memory	Up to 32 GB ECC/ non-ECC DDR4-2133	Weight	4.7 kg (incl. CPU, GPU, memory and HDD)
I/O Interface		Mounting	Wall-mounting with damping brackets
Ethernet	1x Gigabit Ethernet port by Intel® I219-LM 1x Gigabit Ethernet port by Intel® I210-IT	Environmental	
Native Video Port	2x DVI-D connectors for DVI outputs, supporting 1920x1200 resolution	Operating Temperature	-25°C ~ 60°C with 100% CPU/ GPU loading **/**
Serial Port	2x software-programmable RS-232/ 422/ 485 ports	Storage Temperature	-40°C ~ 85°C
USB	4x USB3.0 ports	Humidity	10%~90%, non-condensing
Audio	1x Speaker-out	Vibration	Operating, 1 Grms, 5-500 Hz, 3 Axes (w/ GPU, fan and HDD), according to IEC60068-2-64)
Storage Interface		EMC	CE/ FCC Class A, according to EN 55022, EN 55024 & EN 55032
SATA	4x SATA ports for 2.5" HDD/ SSD installation, supporting RAID 0/ 1/ 5/ 10	<p>** The CPU and GPU loading are applied using Passmark® BurnInTest 8.0 with 35 TDP CPU. Operating Temperature degrades with higher TDP CPU. For detail testing criteria, please contact Neousys Technology</p> <p>*** For sub-zero operating temperature, a wide temperature HDD drive or Solid State Disk (SSD) is required.</p>	

Appearance

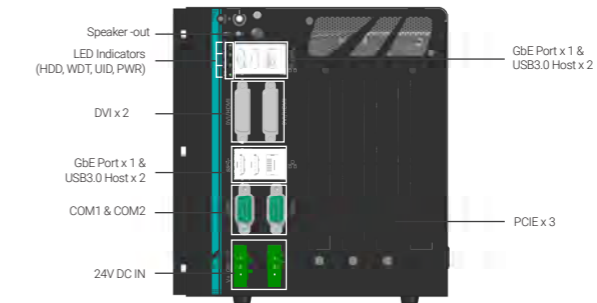

Dimensions

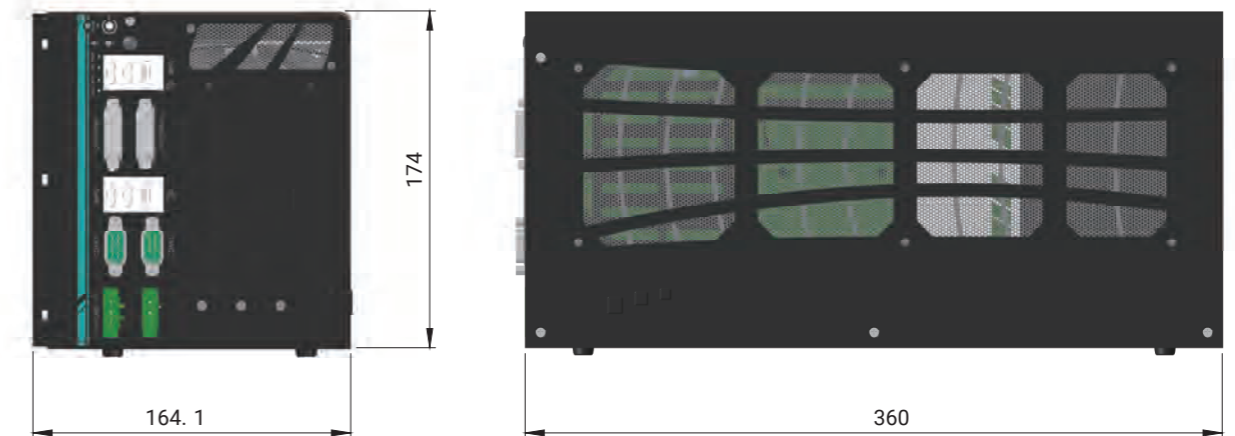

Ordering Information

Model No.	Product Description
Nuvo-6108GC	Industrial-grade GPU computing platform supporting 180W NVIDIA® GTX-1080 and Intel® Xeon® E3 v5 and 6th-Gen Core™ processor
Nuvo-6108GC-TI	Industrial-grade GPU computing platform supporting 250W NVIDIA® GTX-1080 Ti and Intel® Xeon® E3 v5 and 6th-Gen Core™ processor

Optional Accessories

PA-280W-OW	280W AC/DC power adapter 24V/11.67A; 16AWG/100cm; Cord end terminals for terminal block, operating temperature : -30 to 60 °C.
PA-480W-DIN	480W AC-DC power adapter DIN-rail mount, 24V 20A, 90~264VAC/127~370VDC, terminal block, -20 to 70°C, Meanwell SDR-480-24

Nuvo-5095GC

Compact and Wide-Temperature GPU-Computing Platform Supporting 75W NVIDIA® GPU and Intel® 6th-Gen Core™ Processor



Key Features

- Supports NVIDIA® GPU with up to 75W TDP
- Patented thermal design to allow -25°C to 60°C wide-temperature system operation
- Supports Intel® 6th-Gen Core™ i7/i5 LGA1151 CPU
- 6x GigE ports, supporting 9.5 KB jumbo frame
- Up to 32 GB, DDR4-2133 SO-DIMM
- 240 mm x 225 mm x 111 mm compact footprint
- Compatible with MeziO™ interface for function expansion
- Accommodates two 2.5" SATA HDD/SSD with RAID 0/1 support
- Patented ventilation vent* for graphic card

CE FC

*R.O.C Patent No. M534371 / M456527

Introduction

Nuvo-5095GC opens a new chapter for industrial computers. As the first embedded controller targeting at emerging applications of CUDA computing, autopilot, deep learning and virtual reality, Nuvo-5095GC integrates all features required for a compact, reliable and powerful GPU computing platform.

Supporting 75W NVIDIA® GPU (e.g. GTX 1050 Ti), Nuvo-5095GC possesses 768 CUDA cores to deliver tremendous computing power for arithmetic/graphics operations. Neosys' patented Cassette technology and innovative thermal design help to effectively dissipate the heat generated by GPU, thus make this compact system capable of operating reliably at 60°C with 100% GPU loading.

Nuvo-5095GC is based on Intel® Skylake platform, supports 35W/65W 6th-Gen Core™ processors and up to 32GB DDR4 memory. It offers rich I/O functions, such as GbE, USB 3.0 and COM ports, to connect external devices. All these extraordinary features are integrated into a very compact, 240 x 225 x 111 mm footprint. For fast-growing GPU-computing applications, Nuvo-5095GC presents the first industrial-grade, compact and rugged platform incorporating CPU and GPU to offer performance far beyond traditional industrial computers.

Specifications

System Core	Expansion Bus
Processor Supports Intel® 6th-Gen Core™ LGA1151 CPU - Intel® Core™ i7-6700 (8M Cache, 3.4/4.0 GHz, 65W TDP) - Intel® Core™ i5-6500 (6M Cache, 3.2/3.6 GHz, 65W TDP) - Intel® Core™ i7-6700TE (8M Cache, 2.4/3.4 GHz, 35W TDP) - Intel® Core™ i5-6500TE (6M Cache, 2.3/3.3 GHz, 35W TDP)	Mini PCI-E 1x internal mini PCI Express socket with front-accessible SIM socket 1x internal mini PCI Express socket with internal SIM socket (mux with mSATA)
Chipset Intel® Q170 Platform Controller Hub	Expandable I/O 1x MeziO™ expansion port for Neosys' MeziO™ modules
Graphics Independent NVIDIA® GPU (75W TDP) or Integrated Intel® HD 530/510 Controller	Power Supply DC Input 1x 3-pin pluggable terminal block for 8-35VDC DC input
Memory Up to 32 GB DDR4-2133 SDRAM (two SO-DIMM slots)	Remote Ctrl. & Status Output 1x 10-pin (2x5) wafer connector for remote on/off control and status LED output
AMT Supports AMT 11.0	Mechanical Dimension 240 mm (W) x 225 mm (D) x 111 mm (H)
TPM Supports TPM 2.0	Weight 4.8 kg (incl. CPU, GPU, memory and HDD)
I/O Interface Ethernet 6x Gigabit Ethernet ports by Intel® 1x i219 and 5x i210	Mounting Wall-mount by mounting bracket
PoE+ Optional IEEE 802.3at PoE+ PSE for GbE Port 3 ~ Port 6, 80 W total power budget	Environmental Operating Temperature with i7-6700TE, i5-6500TE (35W TDP) -25°C ~ 60°C ** with i7-6700, i5-6500 (65W TDP) -25°C ~ 60°C **/*** (configured as 35W CPU mode) -25°C ~ 50°C **/*** (configured as 65W CPU mode)
USB 4x USB3.0 ports via native XHCI controller 4x USB 2.0 ports	Storage Temperature -40°C ~ 85°C
Video Port (Integrated Graphics) 1x stacked VGA + DVI-D connector 2x DisplayPort connectors, supporting 4K2K resolution	Humidity 10%~90% , non-condensing
Serial Port 2x software-programmable RS-232/422/485 port (COM1 & COM3) 1x RS-232 port (COM2)	Vibration Operating, 5 Grms, 5-500 Hz, 3 Axes (w/ SSD, according to IEC60068-2-64)
Audio 1x Mic-in and 1x Speaker-out	Shock Operating, 50 Grms, Half-sine 11 ms Duration (w/ SSD, according to IEC60068-2-27)
Storage Interface SATA HDD 2x Internal SATA port for 2.5" HDD/SSD installation, supporting RAID 0/1	EMC CE/ FCC Class A, according to EN 55022, EN 55024 & EN 55032
mSATA 1x full-size mSATA port (mux with mini-PCIe)	
Expansion Bus PCI/PCI Express 1x PCIe x16 slot @ Gen3, 8-lanes PCIe signals in Cassette for installing 75W NVIDIA® GPU	

** The high operating temperature specified here is defined under the condition of 100% GPU loading applied using TestMark x64 GPU stress test. For detail testing criteria, please contact Neosys Technology
 ***For sub-zero operating temperature, a wide temperature HDD drive or Solid State Disk (SSD) is required.

Appearance

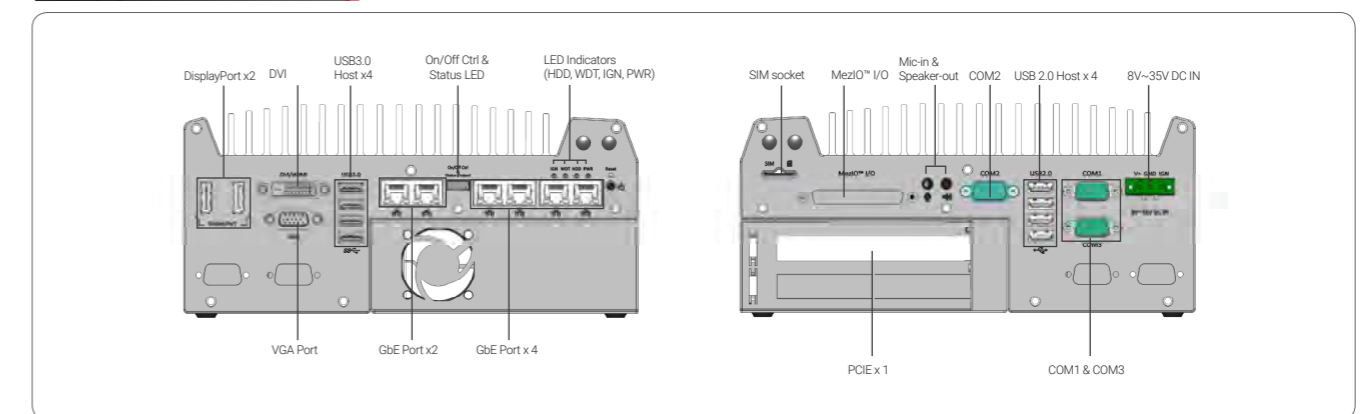

Dimensions

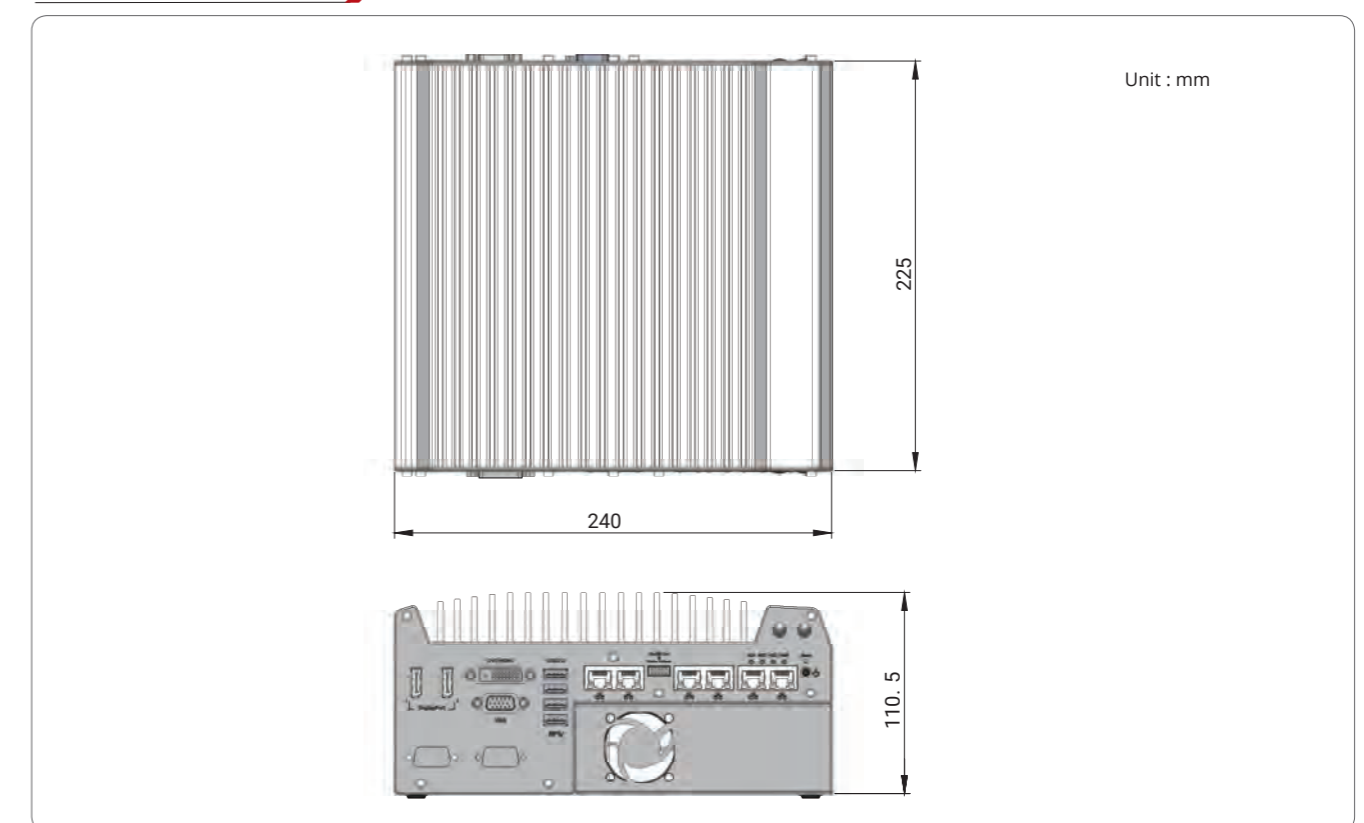

Ordering Information

Model No.	Product Description
Nuvo-5095GC	Intel® 6th-Gen Core™ GPU-computing platform with 6x GbE and MeziO™, supporting selected 75W NVIDIA® GPU
	Option of 802.3at PoE+ for GbE ports 3 ~ 6

Optional Accessories

PA-160W-OW	160W AC/DC power adapter 20V/8A;18AWGx4C/120cm, cord end terminals for terminal block, operating temperature : -30 to 70 °C.		
MeziO™ Modules			
MeziO™-C180	MeziO™ module with 4x RS-232/ 422/ 485 ports and 4x RS-232 ports	MeziO™-V20-EP	MeziO™ module with ignition power control function for in-vehicle application
MeziO™-C181	MeziO™ module with 4x RS-232/ 422/ 485 ports and 4x RS-422/ 485 ports	MeziO™-U4	MeziO™ module with 4x USB3.0 ports
MeziO™-D220	MeziO™ module with 8-CH isolated digital input and 8-CH isolated digital output	MeziO™-G4	MeziO™ module with 4x GigE ports
MeziO™-D230	MeziO™ module with 16-CH isolated digital input and 16-CH isolated digital output	MeziO™-G4P	MeziO™ module with 4x IEEE 802.3at PoE ports

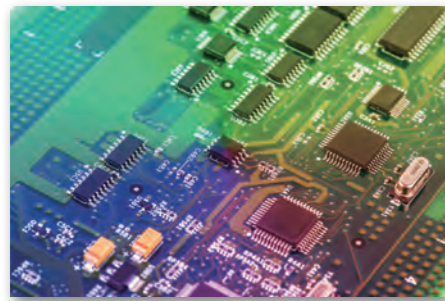
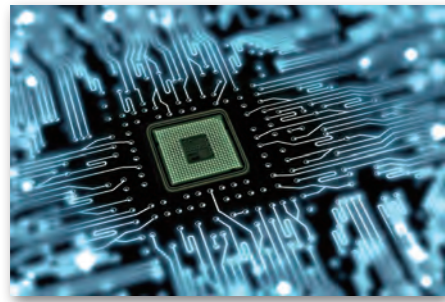

Neousys
MezIO™ Modules

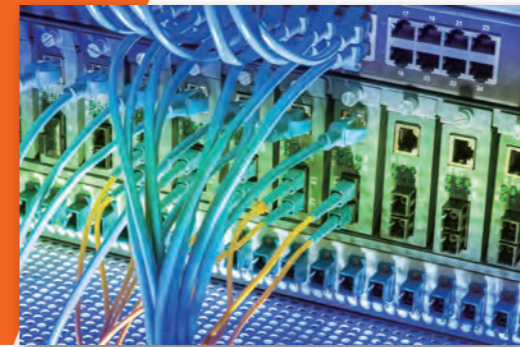

MezIO-C180/MezIO-C181 8-port RS-232/ 422/ 485 MezIO™ Module

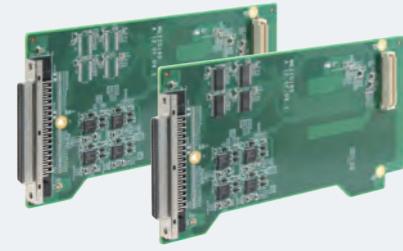

Key Features

- 4x RS-232/422/485 multi-mode ports
- 4x RS-232 ports (C180) or 4x RS-422/485 ports (C181)
- Up to 921.6 Kbps baud rate
- BIOS-configurable mode/termination settings
- Supports Windows 7/8/8.1/10
- SCSI-II 68-pin connector

Specifications

	MezIO-C180	MezIO-C181
# of Port	4x RS-232/ 422/ 485 4x RS-232	4x RS-232/ 422/ 485 4x RS-422/ 485
Baud Rate	50 bps to 921600 bps	
FIFO	256-byte TX and RX FIFOs	
ESD Protection	15 kV	
Interface Signals	RS-232: TxD, RxD, RTS, CTS, DTR, DSR, DCD, GND RS-422: TxD+, TxD-, RxD+, RxD-, GND RS-485: Data+, Data-, GND	
Connector	68-pin SCSI-II female connector	
OS Support	Windows 7/ 8/ 8.1/ 10 and Linux kernel 2.6.32 or later	

Ordering Information

Model No.	Product Description
MezIO-C180-50	4x RS-232/ 422/ 485 and 4x RS-232 ports MezIO™ module, for Nuvo-5000 series and POC-300 Series
MezIO-C180-12	4x RS-232/ 422/ 485 and 4x RS-232 ports MezIO™ module, for POC-120 series
MezIO-C181-50	4x RS-232/ 422/ 485 and 4x RS-422/ 485 ports MezIO™ module, for Nuvo-5000 series and POC-300 Series
MezIO-C181-12	4x RS-232/ 422/ 485 and 4x RS-422/ 485 ports MezIO™ module, for POC-120 series
Cable-S68MD9M-50	SCSI-68(M) to 8x DB-9(M) cable, 50 cm

MezIO-V20 16-mode Ignition Power Control MezIO™ Module

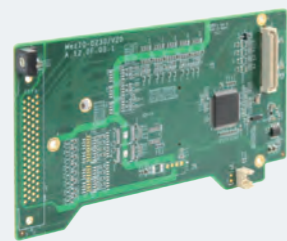

Key Features

- Ignition power control with 16 predefined on/ off delay modes
- Ultra-low 12 mA ignition-off standby power
- Advanced features of ignition control
 - Low-battery protection
 - Guarded power-on/ power-off delay duration
 - System hard-off
 - BIOS POST check
- Supports 12V DC (small vehicle) and 24V DC (bus/ truck) vehicles

Ordering Information

Model No.	Product Description
MezIO-V20	16-mode ignition power control and 1x mini-PCIe socket MezIO™ module for in-vehicle usage
MezIO-V20-EP (Nuvo-5095GC and Nuvo-5000E/P only)	MezIO™ module with ignition power control function for in-vehicle usage

MezIO-D230/MezIO-D220 32/ 16-CH Isolated Digital I/O MezIO™ Module

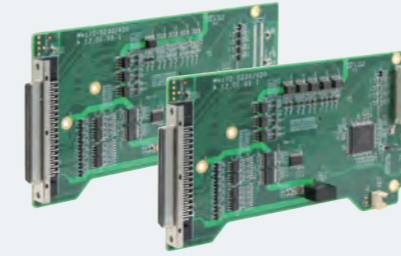

Key Features

- 16-CH isolated DI (D230) or 8-ch isolated DI (D220)
- 16-CH isolated DO (D230) or 8-ch isolated DO (D220)
- 2500 Vrms isolation voltage
- Up to 24V DC operation for DI and DO
- Up to 500 mA sink current on DO channel
- SCSI-II 68-pin connector

Specifications

	MezIO-D230	MezIO-D220
Isolated Digital Input		
# of Port	16	8
Logic Level	Logic high: 5 to 24 VDC ; Logic low: 0 to 1.5 VDC	
Isolation Voltage	2500 Vrms	
Operation Mode	Polling, COS	
Isolated Digital Output		
# of Channel	16	8
Operation Voltage	Up to 24 VDC	
Sink Current	500 mA for each channel (100% duty)	
Isolation Voltage	2500 Vrms	
Operation Mode	Polling, COS	

Ordering Information

Model No.	Product Description
MezIO-D230-50	16-CH isolated DI and 16-CH isolated DO MezIO™ module, for Nuvo-5000 series and POC-300 Series
MezIO-D230-12	16-CH isolated DI and 16-CH isolated DO MezIO™ module, for POC-120 series
MezIO-D220-50	8-CH isolated DI and 8-CH isolated DO MezIO™ module, for Nuvo-5000 series and POC-300 Series
MezIO-D220-12	8-CH isolated DI and 8-CH isolated DO MezIO™ module, for POC-120 series
Cable-S68MM-100	SCSI-68(M) to SCSI-68(M) cable, 100 cm
TB-10	Terminal board with 68-pin SCSI-II female connector and 68-pole terminal block

MezIO-R10 2.5" SATA HDD/ SSD and Mini-PCIe Accommodation MezIO™ Module

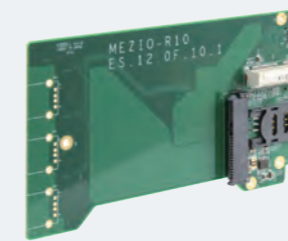

Key Features

- Accommodates one 2.5" SATA HDD/ SSD
- One full-size mini-PCIe port with SIM socket

Ordering Information

Model No.	Product Description
MezIO-R10 (for POC-120MZ only)	2.5" SATA HDD/ SSD and mPCIe accommodation MezIO™ module
MezIO-R11 (for POC-300 series only)	MezIO™ module with 2.5" SATA HDD/SSD
MezIO-R12 (for POC-300 series only)	MezIO™ module with SATA port for 2.5" HDD/ SSD, 4-CH isolated DI and 4-CH isolated DO

MezIO-U4

4-Port USB3.0 MezIO™ Module

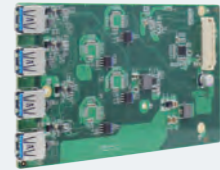

Key Features

- 4 x USB3.0 ports by independent Renesas μPD720202 Host Controllers
- Up to 5 Gbps each port (MezIO-U4-50)
- Support up to 900 mA per port

Specifications

	MezIO-U4-30	MezIO-U4-50
USB Ports	4x USB3.0 ports, compatible with USB 2.0/1.1/1.0	
USB Controller	2 x Renesas μPD720202 Host Controllers	4 x Renesas μPD720202 Host Controllers
USB Connectors	4x USB3.0 Type-A connectors	
USB Per-Port Current Limit	900mA	
Interface Signals	5 Gbps shared by two ports	5 Gbps for each port

Ordering Information

Model No.	Product Description
MezIO-U4-30	4-port USB3.0 MezIO™ module for POC-300 series
MezIO-U4-50	4-port USB3.0 MezIO™ module for Nuvo-5000 series

MezIO - G4P/ MezIO - G4

4-Port GbE with 802.3at PoE+ MezIO™ Module

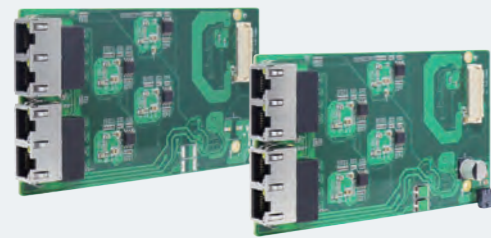

Key Features

- 4x gigabit Ethernet ports
- Compliant with 802.3at PoE+ (MezIO-G4P)
- Supporting 9.5 KB jumbo frame

Specifications

	MezIO - G4P	MezIO - G4
Gigabit Ethernet Port	4x GigE ports by 4x Intel® I210 controllers, supporting 9.5 kB jumbo frame	
PoE Capability	Compliant with IEEE 802.3at-2009 (PoE+), each port delivers up to 25.5 W of power	-
Cable Requirement	CAT-5e or CAT-6 cable, 100 meters maximal	







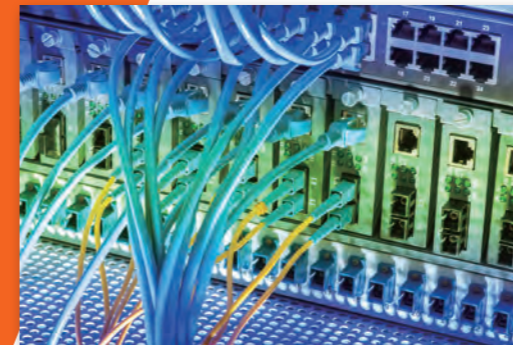



Ordering Information











Model No.	Product Description
MezIO - G4P	4-Port GbE with 802.3at PoE+ MezIO™ Module for Nuvo-5000 series
MezIO - G4	4-Port GbE MezIO™ Module for Nuvo-5000 series

Accessories



List of Optional Cable

Cable	Model Name	Description	Applicable Models
	C-OW-PH-DIO-3M	DIO Flat Cable, with 2.0mm pitch 2x8 female connector/Open End , for digital input/output, length: 3M	<ul style="list-style-type: none"> • POC-200 series
	C-OW-PH-DIO-5M	DIO Flat Cable, with 2.0mm pitch 2x8 female connector/Open End , for digital input/output, length: 5M	<ul style="list-style-type: none"> • POC-200 series
	C-W-W-Remote-1M	Remote control cable, 2x5 Pin female wafer to 2x5 Pin female wafer length: 1M	<ul style="list-style-type: none"> • Nuvo-3000 series • Nuvo-3616VR series • Nuvo-5000 series • Nuvo-5095GC series • Nuvo-5100VTC series • Nuvis-5306RT series
	C-DIN4-2ET-1M	Power Cable, Mini DIN 4 male pin connector to 2 Euro terminal 2Pin, length: 1M	<ul style="list-style-type: none"> • Nuvo-3000 series • Nuvo-4000 series
	C-PH-2U-USB-20CM	USB Cable, 2x USB(female) to PIN header(20 pin, female), for internal USB port connectivity, length: 20CM	<ul style="list-style-type: none"> • Nuvo-3000 series • Nuvo-4000 series • Nuvo-6000 series
	C-DI-DD/VA-15CM	DVI-I to DVI-D/VGA splitter Y cable, length: 15CM	<ul style="list-style-type: none"> • POC-200 series • POC-300 series • Nuvo-4000 series
	C-4P-W-Power-20CM	Power cable, 4 PIN power connector to wafer 2.5 4P Female, provide 12V to add-on card, length: 20CM	<ul style="list-style-type: none"> • Nuvo-2500E/P series • Nuvo-3000E/P series • Nuvo-5000E/P series • Nuvo-7000E/P series
	C-TA-MB-USB-3M	USB3 Type-A to Micro-B cable with latched connectors, Length: 3M	<ul style="list-style-type: none"> • Nuvo-7000E/P Series • PCIe-USB380/340
	CB-PH-2U-USB-20CM	USB Cable, 2x1- Pin header to 2x USB2.0 with bracket.	<ul style="list-style-type: none"> • Nuvo-4000 series • Nuvo-6000 series
	CB-2PH-2D9-RS232-45MM	RS232 Cablebraket, 2x 10 Pin header (Female) to 2x DB9 (Male), length: 45MM	<ul style="list-style-type: none"> • Nuvo-2400 series • Nuvo-4000 series
	CB-PH-D25-DIO-13.6CM	DIO Cablebraket, 26 Pin header(Female)to DB25 (Female), length: 13.6CM	<ul style="list-style-type: none"> • Nuvo-2400 series • Nuvo-4000 series

Cable	Model Name	Description	Applicable Models
	CM-S68-S68-DIO-1M	SCSI-68 (Male) to SCSI-68M (Male) cable, for MeziO DIO card and TB-10, length: 1 M	<ul style="list-style-type: none"> • MeziO-220 • MeziO-230 • Nuvis-5306RT series
	CM-S68-8D9-COM-50CM	SCSI-68(Male) to 8x DB9(Male) Cable, for MeziO COM port card, length: 50CM	<ul style="list-style-type: none"> • MeziO-C180 • MeziO-C181
	C-D9-3D9-RS232-10CM	1x DB9 (Female) to 3x DB9 (Male), length: 10CM	<ul style="list-style-type: none"> • Nuvo-6000 series • POC-300 series
	C-DD-VA-10CM	DVI-D to VGA Cable, for Nuvo-6000 series, length: 10CM	<ul style="list-style-type: none"> • Nuvo-6000 series
	C-M12-RJ45-LAN-5M	M12(8-pole-X-coded) to RJ45, CAT6, length : 5M	<ul style="list-style-type: none"> • Nuvo-7100VTC • Nuvo-5100VTC
	C-M4L-SF-GPS/GSM-15CM	GSM Internal Cable, I-PEX MHF(Female) to SMA (Female), 1.13 coaxial cable, length: 15CM	
	C-M4L-SF-LTE-30CM	LTE Internal Cable, I-PEX MHF(Female) to SMA (Female), 1.13 coaxial cable, length: 30CM	
	C-M4L-SF-GPS/GSM-30CM	GSM Internal Cable, I-PEX MHF(Female) to SMA (Female), 1.13 coaxial cable, length: 30CM	
	C-M4L-RSF-WIFI-30CM	WiFi Internal Cable, I-PEX MHF(Female) to RP SMA(Female), 1.13 coaxial cable, length: 30CM	
	C-M4L-RSF-WIFI-15CM	WiFi Internal Cable, I-PEX MHF(Female) to RP SMA(Female), 1.13 coaxial cable, length: 15CM	
	C-M4-SF-LTE-30CM	LTE Internal Cable, IPEX MHF4(Female) to SMA(Female), for M.2 module, length: 30CM	